



**DEPARTMENT OF RURAL DEVELOPMENT
AND
AGRARIAN REFORM**

**SPECIFICATION OF CONSTRUCTION MATERIALS AND
METHODS TO BE USED FOR AGRICULTURAL ON-FARM
INFRASTRUCTURE**

All references to South African Bureau of Standards Specifications and Codes of Practice in this Document shall be deemed to refer to the latest issue of such specifications and codes as may be amended from time to time and are to be read in conjunction with the latest issue of the National Building Regulations

COPYRIGHT RESERVED

**DIRECTORATE ENGINEERING SERVICES
THIRD EDITION APRIL 2024**

REVISION: DRDAR SCMM-03/2024

Contents

1	SECTION 1: STANDARD CONDITIONS	9
1.1	USE OF LOCALLY MANUFACTURED MATERIALS AND PRODUCTS:	9
1.2	APPLICATION OF CLAUSES:	9
1.3	SAMPLES:	9
1.4	WATER:	9
1.5	STANDARD DETAIL DRAWINGS:	9
1.6	SCALE:	9
1.7	UNITS OF MEASUREMENTS:	9
1.8	INTERPRETATION OF DRAWINGS ETC.:	9
1.9	DETAILS:	10
1.10	VERTICAL TRANSPORT:	10
1.11	SOUTH AFRICAN STANDARD SPECIFICATIONS AND CODES OF PRACTICE:	10
1.12	ACCURACY IN BUILDING WORK:	11
2	SECTION 2: EARTHWORKS	12
2.1	SITE CLEARANCE	12
2.2	EARTHWORKS (GENERAL)	13
2.3	DISPOSAL OF EXCAVATED MATERIAL	18
2.4	MAINTENANCE OF EXCAVATIONS	19
2.5	WATER IN EXCAVATIONS	19
2.6	COMPLETION OF EXCAVATIONS	19
2.7	FILLING	19
2.8	SURPLUS EARTH	20
2.9	GRAVEL DRESSING	20
2.10	FINISHING	20
2.11	EARTH WORKS FOR PIPELINES	21
2.12	METHODS AND PROCEDURES	22
2.13	EXCAVATION	22
2.14	BEDDING FOR PIPES	25
2.15	BACKFILLING	31
2.16	COMPACTION	31
2.17	REINSTATEMENT OF SURFACES	32
2.18	DAMAGE TO ROAD SURFACES	32
2.19	TESTING	33
2.20	TOLERANCES	34
3	SECTION 3: CONCRETE, FORMWORK AND REINFORCEMENT	40
3.1	CEMENT	40
3.2	SAND (FINE AGGREGATE)	40
3.3	STONE (COARSE AGGREGATE)	41
3.4	WATER	41
3.5	CONCRETE	41
3.6	VOLUME BATCHING	42
3.7	WEIGH BATCHING	43
3.8	READY MIXED CONCRETE	43
3.9	STRENGTH CONCRETE	44
3.10	ADMIXTURES TO CONCRETE	44
3.11	SLUMP TEST	45
3.12	CONCRETE TEST CUBES	46
3.13	CONCRETE QUALITY	47

3.14	CONCRETING.....	47
3.15	CURING AND PROTECTION OF CONCRETE	49
3.16	DESCRIPTIONS (PRICES) OF CONCRETE	49
3.17	BUILDING ON CONCRETE FOOTINGS AND BEAMS	50
3.18	CONSTRUCTION JOINTS	50
3.19	ISOLATION OR MOVEMENT JOINTS.....	50
3.20	CUTTING, PUNCHING OR HACKING CONCRETE	50
3.21	FORMING KEY TO CONCRETE FOR PLASTER AND OTHER FINISHES	50
3.22	SLEEVE PIECES, TIES, ETC.....	51
3.23	BAGGED FINISH TO CONCRETE.....	51
3.24	FINISHING OF CONCRETE FOR TROWELLING.....	51
3.25	POWER FLOATED FINISH	51
3.26	“NO-FINES” CONCRETE	52
3.27	FORMWORK.....	52
3.28	SMOOTH FORMWORK	54
3.29	DAMP-PROOF UNDER-SURFACE MEMBRANE.....	54
3.30	REINFORCING RODS.....	54
3.31	CONCRETE REINFORCEMENT	54
3.32	DESCRIPTIONS (PRICES).....	57
PC 3	MEASUREMENT AND PAYMENT	57
4	SECTION 4: MASONRY.....	62
4.1	MATERIALS.....	62
4.2	WORKS MORTAR TESTS.....	64
4.3	CEMENT MORTAR	64
4.4	COMPO MORTAR	65
4.5	BRICKWORK	65
4.6	BRICKWORK IN CEMENT MORTAR	66
4.7	MORTAR JOINTS.....	66
4.8	GROUT IN JOINTS IN BRICK FOUNDATION WALLS	66
4.9	BRICKWORK IN THICKNESSES.....	66
4.10	BRICKWORK IN LININGS	66
4.11	HALF BRICK THICK WALLS.....	66
4.12	CAVITY WALLS	67
4.13	BEAM FILLINGS.....	67
4.14	REINFORCED BRICK LINTELS.....	67
4.15	PRESTRESSED LINTELS.....	68
4.16	BAGGED FINISH TO BRICKWORK	69
4.17	RAKING OUT FOR AND POINTING FLASHINGS.....	69
4.18	MASTIC POINTINGS.....	69
4.19	BUILDING IN	69
4.20	SECURING ROOFS.....	70
4.21	CRAMPS TO WOOD FARMES.....	70
4.22	BEDDING AND POINTING	70
4.23	FACED BRICKWORK.....	70
4.24	FIBRE CEMENT SILLS.....	70
4.25	INSTALLATION OF ELECTRICAL SERVICE	71
4.26	CABLE SLEEVES.....	71
4.27	SPECIAL WORKS	71
4.28	PROTECT AND CLEAN DOWN FACE BRICKWORK.....	72
4.29	DAMP-PROOF COURSE.....	72
4.30	DAMP-PROOF MEMBRANE	72
PC 4	MEASUREMENT AND PAYMENT	73
5	SECTION 5: CEMENT PLASTER.....	75

5.1	CEMENT	75
5.2	SAND	75
5.3	WATER	75
5.4	PLASTER MIXES	75
5.5	MIXING OF PLASTER	76
5.6	SURFACE PREPARATION	76
5.7	PLASTERING	76
PC 5	MEASUREMENT AND PAYMENT	77
6	SECTION 6: STRUCTURAL STEELWORK	78
6.1	STEEL	78
6.2	STRUCTURAL STEELWORK	78
6.3	DETAILED DESIGN AND DRAWINGS FOR STRUCTURAL STEELWORK	80
6.4	PRESERVATION OF STRUCTURAL STEELWORK	81
6.5	INSPECTION	82
PC 6	MEASUREMENT AND PAYMENT	83
7	SECTION 7: METALWORK	84
7.1	STEEL	84
7.2	PRESERVATION OF STEELWORK	84
7.3	MANUFACTURED STEELWORK: GENERAL:	84
7.4	PRESSED STEEL DOOR FRAMES	85
7.5	STEEL ROLLER SHUTTERS	87
7.6	STAINLESS STEEL. ALUMINIUM, BRONZE. ETC.:	88
7.7	STEEL WINDOWS	89
7.8	BURGLER BARS TO STEEL WINDOWS	108
7.9	GAUZE SCREENS TO WINDOWS	108
PC 7	MEASUREMENT AND PAYMENT	108
8	SECTION 8: TIMBER ROOF TRUSSES	111
8.1	MATERIALS	111
8.2	DRAWINGS	114
8.3	JOINTING OF TIMBER MEMBERS	114
8.4	INSTALLATION OF MASONRY ANCHORS	115
8.5	RESHAPING AND RESAWING OF MEMBERS	115
8.6	INSTALLATION OF ROOF TRUSSES, RAFTERS AND PURLIN BEAMS	115
8.7	CEILING ASSEMBLY	117
PC 8	MEASUREMENT AND PAYMENT	117
9	SECTION 9: CEILINGS AND TRAPDOORS	118
9.1	BRANDERING TO CEILINGS:	118
9.2	COVERING TO CEILINGS:	118
PC 9	MEASUREMENT AND PAYMENT	120
10	SECTION 10: STEEL AND POLYCARBONATE ROOF AND SIDE COVERINGS	121
10.1	GENERAL	121
10.2	PROFILES	121
10.3	INSULATION	122
10.4	RIDGING (METAL)	123
10.5	FLAT METAL ROOFS	123
10.6	LININGS TO VALLEYS	124
10.7	FLASHINGS	124
10.8	MAKING GOOD	124
10.9	ROOF TRIMMINGS	124

PC 10	MEASUREMENT AND PAYMENT	124
11	SECTION 11: JOINERY	127
11.1	GENERAL	127
11.2	JOINERY	127
11.3	WOODEN DOORS	127
11.4	HANGING OF DOORS	127
11.5	PAINTING OF DOORS	128
PC 11	MEASUREMENT AND PAYMENT	128
12	SECTION 12: IRONMONGERY	130
12.1	IRONMONGERY	130
12.2	FIXING	130
PC 12	MEASUREMENT AND PAYMENT	130
13	SECTION 13: FLOOR AND WALL TILING	131
13.1	GENERAL	131
13.2	TILE CEMENT	131
13.3	CERAMIC TILES	131
13.4	GLAZED WALL TILING	131
PC 13	MEASUREMENT AND PAYMENT	131
14	SECTION 14: INSTALLATION OF GLAZING IN WINDOWS	133
14.1	MATERIALS	133
14.2	PREPARATION	133
14.3	GLAZING WITH PUTTY	134
14.4	MIRRORS	134
PC 14	MEASUREMENT AND PAYMENT	134
15	SECTION 15: PLUMBING AND DRAINAGE	135
15.1	GENERAL	135
15.2	STORM-WATER DRAINAGE	138
15.3	SOIL AND WASTE-WATER DRAINAGE	140
15.4	WATER SUPPLIES, FIRE SERVICE AND SANITARY PLUMBING AND FITTINGS	144
PC 15	MEASUREMENT AND PAYMENT	149
16	SECTION 16: PAINTING	155
16.1	PREPARATORY WORK FOR PAINTING	155
16.2	SURFACES TO BE DRY	155
16.3	PAINTS	155
16.4	APPLICATION OF PAINT	156
16.5	PRIMING	156
16.6	LEAVE PERFECT	156
PC 16	MEASUREMENT AND PAYMENT	156
17	SECTION 17: ELECTRICAL INSTALLATION	158
17.1	GENERAL	158
17.2	INSTALLATION AND TERMINATION OF CONDUITS AND CONDUIT ACCESSORIES	160
17.3	INSTALLATION OF WIRING CHANNELS, UNDERFLOOR DUCTING AND POWER SKIRTING	172
17.4	INSTALLATION OF CABLE TRAYS AND LADDERS	176
17.5	FIXING MATERIALS	178
17.6	WIRING	179
17.7	INSTALLATION OF CABLES	182
17.8	INSTALLATION OF LIGHT SWITCHES AND SOCKET-OUTLETS	194

17.9	PHOTO ELECTRIC DAYLIGHT SENSITIVE SWITCH FOR OUTSIDE LIGHTING	196
17.10	INSTALLATION OF LUMINAIRES	197
17.11	CONNECTIONS TO EQUIPMENT	200
17.12	EARTHING	201
17.13	INSPECTIONS, TESTING, COMMISSIONING AND HANDING OVER.....	206
17.14	SCHEDULE OF MATERIALS.....	207
PC 17	MEASUREMENT AND PAYMENT	208
18	SECTION 18: ROADSTONE SURFACING	211
18.1	EXCAVATIONS	211
18.2	PREPARATION OF FORMATION	211
18.3	SABUNGA BASE COURSE	211
18.4	INTERLOCKING CONCRETE ROADSTONES	212
18.5	CONCRETE KERBING.....	213
PC 18	MEASUREMENT AND PAYMENT	213
19	SECTION 19: STOCK PROOF FENCES.....	215
19.1	SCOPE.....	215
19.2	FENCING TOOLS	215
19.3	APPROVAL OF MATERIALS AND TOOLS	215
19.4	MATERIALS AND DIMENSIONS.....	215
19.5	CLEARING THE FENCE LINE	217
19.6	CONSTRUCTION	217
19.7	EXISTING FENCES	219
19.8	REQUIREMENTS FOR THE FENCE.....	219
PC 19	MEASUREMENT AND PAYMENT	222
20	SECTION 20: LARGE STOCK PRE-FABRICATED ANIMAL HANDLING FACILITIES.....	225
20.1	SCOPE.....	225
20.2	CATTLE CRUSH	225
20.3	HEAVY DUTY NECK- CLAMP, SCALE AND CRATE COMBINATION	225
20.4	SCALE AND LOAD BARS	226
20.5	CENTRE POLE	226
20.6	CATTLE KRAAL SIDES/GATES	227
20.7	CATTLE LOADING RAMP (BARROW)	227
20.8	ACCESS GATE.....	228
20.9	STEEL PIN	228
20.10	SINGLE AXLE PORTABLE TRAILER	229
20.11	DEMONSTRATION.....	229
PC 20	MEASUREMENT AND PAYMENT	229
21	SECTION 21: STANDARD STOCK WATER SYSTEM	230
21.1	SCOPE	230
21.2	EARTH WORKS.....	230
21.3	SAFETY	230
21.4	CONCRETE WORKS.....	231
21.5	MATERIALS AND DIMENTIONS FOR WATER TANKS TERRAIN FENCE.....	232
21.6	WATER TANKS TERRAIN AND PREPARATION	233
21.7	WATER TANKS AND PLATFORM	233
21.8	DRINKING TROUGHS AND PLATFORMS.....	234
21.9	PIPES AND FITTINGS.....	234
21.10	STEEL PIPE ANCHOR BLOCKS (ABOVE GROUND).....	234
21.11	WIND TURBINE AND SUBMERSIBLE ELECTRIC PUMPSET	235
21.12	SPECIALS, VALVES, EXTRA'S	235

21.13	BOREHOLE PUMP PROTECTION	236
PC 21	MEASUREMENT AND PAYMENT	236
22	SECTION 22: CATTLE PLUNGE DIP WITH STEEL HANDLING FACILITY	238
22.1	SCOPE.....	239
22.2	EARTH WORKS	239
22.3	CONCRETE WORKS.....	240
22.4	HANDLING FACILITY (STEEL COMPONENTS).....	242
22.5	MATERIALS AND DIMENTIONS FOR EVAPORATION POND FENCE	243
22.6	SLUDGE PUMP	244
22.7	STEEL STORAGE SHED	244
22.8	STOCK WATER SYSTEM.....	244
22.9	STOCK FENCE AROUND DIP TANK AND FACILITIES	245
PC 22	MEASUREMENT AND PAYMENT	245
23	SECTION 23: CATTLE PLUNGE DIP WITH TIMBER HANDLING FACILITY	246
23.1	SCOPE.....	247
23.2	EARTH WORKS	247
23.3	CONCRETE WORKS.....	248
23.4	HANDLING FACILITY (TIMBER COMPONENTS)	250
23.5	MATERIALS AND DIMENTIONS FOR EVAPORATION POND FENCE	252
23.6	SLUDGE PUMP	252
23.7	STEEL STORAGE SHED	253
23.8	STOCK WATER SYSTEM.....	253
23.9	STOCK FENCE AROUND DIP TANK AND FACILITIES	253
PC 23	MEASUREMENT AND PAYMENT	253
24	SECTION 24: STANDARD SHEARING SHED.....	255
24.1	SCOPE.....	256
24.2	EARTH WORKS	256
24.3	CONCRETE WORKS.....	257
24.4	MASONRY WORKS	258
24.5	WINDOWS DOORS AND FITTINGS	258
24.6	PAINT WORK	261
24.7	ROOFING.....	261
24.8	FENCING.....	261
24.9	ELECTRICAL	261
24.10	ANIMAL HANDLING FACILITIES	264
25	SECTION 25: SMALL STOCK ANIMAL PRE-FABRICATED HANDLING FACILITIES.....	265
25.1	SCOPE.....	265
25.2	PREFARBICATED GATE SECTIONS	265
25.3	FOOT BATH.....	268
PC 25	MEASUREMENT AND PAYMENT	268
26	SECTION 26: SHEARING EQUIPMENT	269
26.1	SCOPE.....	269
26.2	WOOL SORTING TABLE.....	269
26.3	PIECE PICKING TABLE	269
26.4	WOOL BINS	269
26.5	WOOL BASKETS.....	269
26.6	BALE LIFTING HOOKS.....	269
26.7	SHEARING BOARDS	269
26.8	SINGLE BASE GEAR WOOL PRESS	270

26.9	WOOL SCALE	270
26.10	SHEEP SHEARS	270
26.11	DIP HOOK AND STAFF	270
26.12	DEMONSTRATION OF EQUIPMENT.....	270
PC 26	MEASUREMENT AND PAYMENT	271
27	SECTION 27: PIT TOILET	272
27.1	SCOPE.....	272
27.2	EARTH WORKS	272
27.3	CONCRETE WORKS.....	273
27.4	MASONRY WORKS	274
27.5	DOORS AND FITTINGS	274
27.6	PAINT WORK	276
27.7	ROOFING	276
PC 27	MEASUREMENT AND PAYMENT	276
28	SECTION 28: SHEEP PLUNGE DIP TANK AND EVAPORATION POND.....	277
28.1	SCOPE.....	277
28.2	SUPPORTING SPECIFICATIONS	277
28.3	EARTH WORKS	277
28.4	CONCRETE WORKS.....	278
28.5	FENCING.....	279
29	SECTION 29: SMALL STOCK HANDLING FACILITY.....	280
29.1	SCOPE	280
29.2	SUPPORTING SPECIFICATIONS	280
29.3	MATERIALS AND DIMENSIONS.....	280
29.4	CONSTRUCTION:	281
29.5	EXISTING FENCES	281
29.6	REQUIREMENTS FOR THE FENCE.....	282
29.7	WORKMANSHIP	283
PC 29	MEASUREMENT AND PAYMENT	284
30	SECTION 30: LARGE STOCK HANDLING FACILITY	286
30.1	SCOPE	286
30.2	SUPPORTING SPECIFICATIONS	286
30.3	EARTH WORKS	286
30.4	CONCRETE WORKS.....	287
30.5	MASONRY WORKS	288
30.6	POLES.....	288
30.7	GATES.....	290
30.8	BOLTS, NUTS AND WASHERS.....	290
30.9	BODY & NECK CLAMP, SCALE COMBINATION.....	290
PC 30	MEASUREMENT AND PAYMENT.....	294
31	SECTION 31: CATTLE SPRAY DIPPING FACILITY (STEEL)	296
31.1	SCOPE.....	296
31.2	EARTH WORKS	296
31.3	CONCRETE WORKS.....	297
31.4	HANDLING FACILITY (STEEL COMPONENTS).....	299
31.5	MATERIALS AND DIMENTIONS FOR SPRAY RESERVIOR TANK AND PUMP TERRAIN	301
31.6	STEEL STORAGE SHED	301
31.7	STOCK WATER SYSTEM.....	302
31.8	PERIMETER STOCK FENCE AROUND DIP TANK AND FACILITIES.....	302

PC 31	MEASUREMENT AND PAYMENT	302
32	SECTION 32: CATTLE SPRAY DIPPING FACILITY (TIMBER)	304
32.1	SCOPE.....	304
32.2	EARTH WORKS	304
32.3	CONCRETE WORKS.....	305
32.4	HANDLING FACILITY (TIMBER COMPONENTS)	307
32.5	MATERIALS AND DIMENTIONS FOR SPRAY RESERVIOR TANK AND PUMP TERRAIN	309
32.6	STEEL STORAGE SHED	310
32.7	STOCK WATER SYSTEM.....	310
32.8	PERIMETER STOCK FENCE AROUND DIP TANK AND FACILITIES	311
PC 32	MEASUREMENT AND PAYMENT	311
33	SECTION 33: STANDARD MULTI-PURPOSE SHED.....	313
33.1	SCOPE	313
33.2	SUPPORTING SPECIFICATIONS	313
33.3	MATERIALS.....	313
33.4	EARTH WORKS	313
33.5	CONCRETE WORKS.....	315
33.6	MASONRY WORKS	316
33.7	STEEL STRUCTURE	316
PC 33	MEASUREMENT AND PAYMENT	318
33.8	PIT TOILET	318
33.9	SHEARING EQUIPMENT.....	319
33.10	PORTABLE KRAALS & FOOTBATH	319
33.11	PERIMETER FENCE (SF)	319
34	SECTION 34: DIP TANK STORAGE SHED.....	320
34.1	SCOPE.....	320
34.2	EARTH WORKS	320
34.3	CONCRETE WORKS.....	320
34.4	STEEL SHED STEEL COMPONENTS	321
PC 34	MEASUREMENT AND PAYMENT	322
35	SECTION 35: SITING, DRILLING AND TESTING OF BOREHOLES FOR STOCK WATER PUPOSES.....	324
35.1	PROFESSIONAL SERVICES	324
35.2	GENERAL CONDITIONS.....	327
35.3	DRILLING AND TESTING OF BOREHOLE/S.....	329
PC 35	MEASUREMENT AND PAYMENT	340

1 SECTION 1: STANDARD CONDITIONS

1.1 USE OF LOCALLY MANUFACTURED MATERIALS AND PRODUCTS:

Materials and products manufactured in South Africa shall be used in carrying out the work to which this specification refers, unless an imported product is prescribed specifically, or when no suitable locally manufactured product for the specific use is available.

1.2 APPLICATION OF CLAUSES:

All clauses in this specification which describe the materials and methods to be used in carrying out the work specified in the specification of work to be done, or indicated on the drawings, or included in the bills of quantities, or in any detail drawings, or instructions issued by the Engineer to the Contractor during the progress of the work, shall be considered as applying to the performance of the contract.

1.3 SAMPLES:

The Contractor shall furnish without delay, such samples and/or certificates as called for or may be called for by the Engineer. Materials and/or workmanship not corresponding with approved samples may be rejected.

1.4 WATER:

Clean, fresh water free from vegetable or organic matter, earth, clay, acid or alkaline substances either in suspension or in solution, other than those used for purification thereof by the responsible authority, shall be used throughout. Where there is any reason to suspect the presence of impurities, the Engineer may require the Contractor to obtain a chemical analysis of the water by a competent analyst at his own cost. Should the water prove unsuitable for use the Contractor must procure water of an approved source.

1.5 STANDARD DETAIL DRAWINGS:

All standard detail drawings applying to a particular service and referred to in this document, in the specification or in the bills of quantities, may be seen by Tenderers at the office of the Engineer for the carrying out of the work.

1.6 SCALE:

The scale to which the drawings are prepared is only to be made use of when no figured dimensions are given, either on the drawings or in the specification. Figured dimensions are always to be followed though they may not coincide with the scale of the drawings. Where possible dimensions are to be taken from all relevant existing buildings.

1.7 UNITS OF MEASUREMENTS:

Units of measurements have been standardised in accordance with "Système International d'Unités" (SI).

1.8 INTERPRETATION OF DRAWINGS ETC.:

Should any part of the drawings, specification or bills of quantities not be clearly intelligible to the Contractor or that the materials or articles to be used in the execution of the works be considered insufficiently described, the Engineer shall be requested in writing, to make clear, also in writing, his requirements, failing which the Contractor shall be liable to make, at his own expense, any alterations or substitutions rendered necessary through incorrect interpretation of such drawings, specification or bills of quantities.

1.9 DETAILS:

Upon receipt of detail drawings for any work the Contractor shall, before putting that work in hand, ascertain that the dimensions given on the Detail Drawings correspond with the dimensions of any work already built which governs the sizes of the work for which the detail is given. In the event of the detail drawings not agreeing with the work already built, the drawings shall be at once returned for alterations as no claim for extra work will be entertained in this respect.

1.10 VERTICAL TRANSPORT:

Vertical transport for workmen and materials is entirely the responsibility of the Contractor. Permission is to be obtained shafts by the Contractor on shaft(s), make good and clean Contractor wishes to commence.

1.11 SOUTH AFRICAN STANDARD SPECIFICATIONS AND CODES OF PRACTICE:

STANDARD SPECIFICATIONS:

SANS 23-4 (2003) Steel Wire and Product for Fences – Part 4

SANS 62-2, Steel pipes – Part 2: Screwed pieces and pipe fittings of nominal size not exceeding 150 mm

SABS 82 Bending Dimensions of Bars for Concrete Reinforcement

SANS 110 Sealing compounds for the building industry, two-component, polysulphide base”

SANS 121/ISO 1461, Hot dip galvanized coatings on fabricated iron and steel articles – Specifications and test methods

SABS 135 ISO metric black bolts, screws, and nuts (hexagon and square)

SANS 187 Butyl rubber (for waterproofing)

SABS 248 Bituminous Damp-Proof Courses

CKS 264 Flat mild steel washers

SABS 307 – 309 Bitumen Emulsion

SABS 312 Red Lead Base Primers for Structural Steel

SABS 455 Covered electrodes for manual arc welding of carbon steel

SABS 471 Portland Cement (ordinary, rapid hardening and sulphate- resisting)

SABS 563 Specifications for Structural Timber

SANS 580 Chloroprene rubber sheet (for waterproofing)

SABS 626 Portland Blastfurnace Cement

SANS 630 Decorative high gloss enamel paint for interior and exterior use

SABS 678 Primers for Wood for Interior and Exterior Use

SABS 681 Undercoats for Paints

SABS 684 Structural Steel Paint

SABS 723 Wash Primer (Metal Etch Primer)

SABS 763 Hot-dip (Galvanised) Zinc Coatings other than on continuously zinc-coated sheet and wire

SANS 801 Epoxy-tar paints

SABS 831 Portland Cement 15 (Ordinary and Rapid Hardening)

SANS 8779: 2016: Plastic Piping Systems – Polyethylene (PE) Pipes for Irrigation

SANS 912 Calcium Plumbate Primer

SABS 920 Steel Bars for Concrete Reinforcement

SABS 934 Hot-dip (Galvanised) Zinc Coatings on Steel Sheet and Strip

SABS 952 Polyolefin film for damp-proofing and waterproofing in buildings

SABS 1024 Welded Steel Fabric for Concrete Reinforcement

SABS 1090 Sand for Plaster and Mortar

SABS 1200 Standardized Specifications for Civil Engineering Construction

SANS 1305 Sealing surround for the building industry, one-component Silicone-rubber based

SABS 1431 300W Steel grade

SANS 2001-BE1 Construction Works. Part BE1: Earthworks (general)

SANS 2001-BS1 Construction Works. Part BS1: Site Clearance

SANS 2001-CC1 Construction Works. Part CC1: Concrete Works (Structural)

SANS 2001-CC2 Construction Works. Part CC2: Concrete Works (Minor Works)

SANS 2001-CG1 Construction Works. Part CG1: Installation of glazing in window and door frames
SANS 2001-CM1 Construction Works. Part CM1: Masonry walling
SANS 2001-CS1 Construction Works. Part CS1: Structural steelwork
SANS 2001-CT2 Construction Works. Part CT2: Structural timberwork (roofing)
SANS 2001-EM1 Construction Works. Part EM1: Cement plaster
SANS 2001-DP1 Construction Works. Part DP1: Earthworks for buried pipelines and prefabricated culverts
DIN 1025 "Structural steel IPE Sections
ISO 3575 Hot-dip (galvanized) zinc coatings on steel sheet and strip (incorporating Amendment 1, February 1970)

CODES OF PRACTICE:

SABS 03 The Protection of Buildings against Lightning
SABS 021 Waterproofing of Buildings
SABS 044 Code of practice for welding
SABS 064 Preparation of Steel Surfaces for coating
SABS 0155 Accuracy in building
SABS 0040 The application of the National Building Regulations
SANS 0160 General procedures and loadings to be adopted for the design of buildings
SANS 0162 Part 1 Code of practice for the use of Structural Steel
SABS-ISO 9000 Series Quality management systems

STANDARD TEST METHODS:

STM 861 Sampling of freshly mixed concrete
STM 862 Slump of freshly mixed concrete
STM 863 Compressive strength of concrete
(IN ALL CASES THE LATEST PUBLICATION OR REVISION SHALL APPLY.)

1.12 ACCURACY IN BUILDING WORK:

The method of measurement and accuracy of dimensions required for the setting out of structures and for completed building work shall be as described in SABS Code of Practice 0155, unless otherwise specified in this document.

2 SECTION 2: EARTHWORKS

2.1 SITE CLEARANCE

Applicable standard: SANS 2001 – Construction Works Part BS1: Site clearance.

SANS 2001-BS1 covers removal of vegetation, fences, posts, litter and building rubble, boulders of size up to 0.15 m³, and surface and subsurface obstructions, and demolition and removal of structures (including their basements, if any), not directly associated with or incidental to any excavation.

Clear site for the whole area of the ground to be built upon up to a distance of at least 3 m beyond the perimeter of the structure of building(s) and/or extent of steps, pavings, etc to the level as indicated on the drawings.

This operation shall be deemed to include the following activities:

1. The removal and disposal of all trees and bushes (complete with roots), other vegetation, rubbish, hedges, fences, and all other material that might interfere with the construction of other works to designated sites as directed by the Engineers Representative.
2. The removal of all litter, building rubble, rocks and boulders that are lying on the surface to be cleared, or exposed during the clearing operations and disposing thereof to designated sites as directed by the Engineers Representative.
3. The removal and stacking of re-usable materials as specified by the Engineers Representative.
4. The scarifying, loosening and breaking up of hardened areas by ripping or excavation to a depth of 200 mm or otherwise specified by the Engineers Representative.

All topsoil shall be conserved for later use over the cleared area that are to be levelled over the terrain.

The level of the finished earth works shall be as shown on the drawings.

Tree trunks shall be disposed of by stockpiling at a designated area identified by the Engineers Representative.

2.1.1 GRUBBING:

All stumps and roots larger than 75 mm in diameter shall be removed to a depth of at least 600 mm below the finished level, and at least 100 mm below the original ground level. Where a roadbed or other area has to be compacted, all stumps and roots, including matted roots shall be removed to a depth of at least 200 mm below the cleared surface.

Except in borrow areas, cavities resulting from grubbing shall be backfilled with suitable material and compacted to a density of 90 % of the modified AASHTO maximum dry density or that of the surrounding ground, whichever is the lesser.

2.1.2 DISPOSAL OF MATERIAL:

Material obtained from clearing and grubbing and from the demolition of structures shall be disposed of in borrow pits or other suitable places as specified by the Engineers Representative and shall be covered with soil or gravel. Consumable materials on site may be disposed of by means of burning, unless otherwise specified by the Engineers Representative.

All tree trunks and branches of girth exceeding 0,5 m shall be stripped of secondary branches, sawn into transportable lengths and stacked at designated sites, as specified by the Engineers Representative.

Fencing wire shall be neatly wound into rolls or coils and all such wire, together with all fence posts and other reusable material from structures, etc., shall be stacked at sites specified by the Engineers Representative.

All other materials that are to be reused, shall be stacked at sites as specified by the Engineers Representative.

2.1.3 BRANCHES OVERHANGING BOUNDARIES:

The branches of trees that are to be left standing shall be so trimmed as not to encroach upon the space (of height at least 7 m) vertically above any carriageway or any other designated area.

2.1.4 CONSERVATION OF INDIVIDUAL TREES:

Individual trees that, in terms of the scope of work, are identified to be conserved, shall be left standing, uninjured and protected against damage from all construction activities.

2.1.5 RE-CLEARING OF VEGETATION:

If during the period of construction vegetation should again grow on any portion of the site, borrow areas, or other areas that have been cleared in accordance with this specification, re-clearing might be required. Such re-clearing shall include the removal and disposal of grass, shrubs and other vegetation, as in the first clearing operation.

2.1.6 CONSERVATION OF TOPSOIL:

Where topsoil is required to be conserved as directed by the Engineers Representative, the topsoil together with any grass and other suitable vegetation shall be removed and placed at a designated area as directed by the Engineers Representative. If not used immediately, such topsoil shall be temporarily stockpiled for later use.

2.1.7 COMPLIANCE WITH THE REQUIREMENTS:

The required levels of compaction shall be established by means of selected fill material replacement.

The density of the backfilling may be compared to the density of the surrounding ground.

2.2 EARTHWORKS (GENERAL)

Applicable standard: SANS 2001 – Construction Works Part BE1: Earthworks (general).

SANS 2001-BE1 covers the excavation, filling, compaction and finishing of general excavations for buildings, carried out with heavy construction equipment or light construction equipment, or by hand.

2.2.1 NOTIFICATION BY CONTRACTORS AND EXCAVATORS:

In terms of the Occupational Health and Safety Act, 1993 (Act No. 85 of 1993), every Contractor shall at least 7 days before he/she commence with the construction work notify the provincial director in writing if the intended construction work will :-

- a) Include excavation work;
- b) Include working at a height where there is a risk of falling;
- c) Include the demolition of a structure; or
- d) Include the use of explosives to perform the construction work.

2.2.2 EXCAVATIONS FOR CUT AND FILL

Dimensions of cuts.

The dimensions of cuts (including rock cuts) shall be in accordance with the details of the typical cross-section shown on the drawings and as may be further defined or amended by the Engineer during construction.

All cuts carried below the designated level of the bottom of the platform shall be backfilled with suitable material that has a CRR of at least 7 and compacted at the Contractor's own expense.

(NOTE: In the case of cuttings made in hard or boulder material where a certain amount of overbreak is inevitable, provision shall be made to compensate the Contractor for the cost of overbreak on the floor and of backfilling over-excavated sections.)

Use of materials

a) General.

The Contractor shall conserve all suitable material and he shall not borrow, spoil, or waste any material without approval. The order of constructing the fill shall be so arranged as to make the best possible use of material occurring in cuttings. Priority shall be given to the construction of high fills to allow time for the designed settlement to take place. If a material selected by the Engineer for a particular purpose becomes contaminated, is incorrectly used, or becomes unavailable through injudicious planning of excavation or borrow pit operations, the Contractor shall replace the contaminated material and make good any shortfall with material of quality at least equal to that of the said selected material, excavated and transported from borrow pits at the Contractor's own expense.

b) Cut to spoil.

Material arising from cuttings that is unsuitable for use in any part of the Works or surplus to requirements shall be spoiled at points designated by the Engineer and in a manner satisfactory to him. Spoil heaps shall be neatly trimmed and finished to even free drainage surfaces.

c) Cut to fill.

All suitable and approved material excavated from the construction site shall, as far as is practicable, be used in the construction of fill and for such other purposes as may be shown on the drawings or as directed. The Contractor shall so plan his operations and in particular his cut and fill operations, that all cut material is used in the manner that, in the opinion of the Engineer, is most appropriate.

Coarse rock shall be utilized for the construction of the lower layers of fills that are high enough to accommodate thick layers or, where so required or directed, shall be conserved and used as directed by the Engineer.

Material surplus to requirements shall be placed on designated disposal sites.

Topsoil shall be stockpiled and preserved for later use or it shall be hauled directly to areas that are required to be topsoiled in terms of the project specification and scheduled.

No material other than that arising from the excavation of cuttings, foundations, and drains, may be taken from within the construction site, unless otherwise authorized.

d) Borrow.

The Engineer may permit or instruct cuts to be widened or slopes of cuts to be flattened in lieu of using borrow pits. Where sufficient quantities of suitable cut material are not available, additional material shall be excavated from borrow pits.

Where borrow pits are not designated, the Contractor shall locate suitable sources of material. The Engineer may order which of the sources of approved material shall be used by the Contractor at any particular time.

2.2.3 EXCAVATIONS FOR GENERAL EARTHWORKS AND FOR STRUCTURES

Excavation work shall be so executed that material

- a) excavated and placed as directed and materials from excavations shall be used in preference to materials from borrow pits or other sources;
- b) shall be transported directly to its final position without being stockpiled, and if stockpiling is unavoidable, materials intended for different uses shall be stockpiled separately.

After an area has been stripped, excavation shall be carried out first to any general levels to which the ground has to be reduced and then for foundations, footings, etc., to the depths indicated in the drawings or to such greater depths as may be required to reach a suitable founding stratum.

Except where otherwise shown in the construction drawings, required in terms of the specification data or dictated by the requirements for safeguarding excavations, excavation shall be so carried out and the excavated surfaces so prepared by trimming to the outline of the concrete work shown in the drawings, that the excavated surfaces will act as formwork for the concrete works.

Except where provision for working space has been made in the scope of work, each excavated surface on which, or against which, a permanent concrete structure will be placed shall be prepared by trimming to ensure that there is no projection outside the specified tolerance into the excavation profile. Such surface shall be cleaned by hand or by air or by other effective means to remove all loose material.

Immediately before any permanent construction is commenced, the bottom of each excavation shall be cleaned of all loose material, and soft material shall be rammed or removed, as required.

Excavated surfaces that will remain permanently exposed shall be trimmed in a neat and workmanlike manner and shall be graded to provide suitable drainage, as shown in the drawings.

Cuts shall be made and trimmed neatly to the side slopes, widths, levels, grades, and sections shown in the construction drawings.

Unless otherwise specified in the scope of work, the finished formation width of private sidings shall be at least that shown in figure 1, appropriate to the layout.

Where required in the specification data, the slopes of cuttings shall not be trimmed to a smooth surface but left as cut by a bulldozer or scraper to provide ledges to retain topsoil.

2.2.4 EXCAVATIONS FOR FOUNDATIONS AND FLOORS:

Excavation work shall be so executed that material excavated and that does not contain more than 10% rock or hard fragments retained on a sieve of nominal aperture size 50 mm shall be transported directly to its final position without being stockpiled, and if stockpiling is unavoidable, materials intended for re-use shall be stockpiled separately from the other excavated materials and materials from excavations shall be used in preference to materials from borrow pits or other sources.

After an area has been stripped, excavation of trenches and holes for foundations shall be excavated to the several lengths, widths and levels shown on drawings to which the ground has to be reduced and then for foundations, footings, etc., to the depths as shown on the drawings or to such other depths as may be directed by the Engineers Representative to ensure a good foundation.

Bottoms of trenches and holes shall be level, with sides trimmed vertical for the full width from top to bottom. The bottoms of trenches shall be stepped as shown but if the stoppings are not shown on drawings or are not otherwise directed on site, the stepping shall be of at least the thickness specified for the concrete footings but shall be adjusted downwards to conform with an exact number of brick courses where necessary. Any excavations taken out to deep shall be made up to correct levels with approved fill material by the Engineers Representative and shall be capable of sufficient compaction to avoid settlement and shall be capable of placement without significant voids all at the Contractor's expense.

The ground under solid floors shall be excavated where necessary and levelled in readiness for the laying of the surface beds.

Before commencing any earthworks, the Contractor shall satisfy himself as to the accuracy of any levels indicated on the drawings as no claim will be entertained at a later date for any allege inaccuracy in such levels.

Degree of accuracy for excavations required is:

- a) Position on plan:- pd in plan of any point measured from the nearest grid line ± 35 mm.
- b) Dimensions on plan:- pd from the design dimensions ± 50 mm.
- c) Foundation level (i.e. level of underside of concrete except floor slab):- pd in level of surface of excavation trimmed to receive concrete ± 50 mm.
- d) Level:- pd from designed level with reference to the nearest transferred benchmark of any floor slab ± 15 mm.

Except where provision for working space has been made in the scope of work, each excavated surface on which, or against which, a permanent concrete structure will be placed shall be prepared by trimming to ensure that there is no projection outside the specific tolerance into the excavation profile. Such surface shall be cleaned by hand to remove all loose material.

Immediately before any permanent construction is commenced, the bottom of each excavation shall be cleaned of all loose material, and soft material shall be rammed or removed, as required.

2.2.5 EXCAVATIONS TO REDUCE LEVELS:

The ground outside the buildings shown to be reduced in levels, shall be excavated and levelled or graded to falls as shown on the drawings.

2.2.6 EXCAVATIONS FOR WORKING SPACE:

Working space for formwork to sides of all concrete, except columns, has been measured only where the concrete face is less than 750mm from the face of the measured excavation.

Working space for formwork to sides of columns has been measured for the width of the column face only where both:

- a) the top of the column base is more than 1,5m below the commencing level of the excavation, and
- b) the column face is less than 500mm from the face of the measured excavation.

No claim will be considered for any working space for formwork to concrete other than as above described for working space beyond the sides of trench excavations for the building of brick or block walls.

Descriptions of excavations for working space shall be deemed to include any additional risk of collapse so incurred and the returning and compacting of the excavated material as described.

2.2.7 DEFINITIONS:

Earth shall mean ground that can be removed by hand tools and shall include loose gravel, clay, made up ground, loose or soft shale, loose oukclip and any loose boulders less than 75mm in diameter.

Soft rock shall mean rock that can be loosened by hand, pick or crowbar and includes hard shale, compact oukclip, stone of a similar hardness and boulders from 75mm diameter up to 0,03 cubic metres in volume.

Hard rock shall mean granite, quartzitic sandstone, slate and rock of similar or greater hardness and boulders from over 0,03 cubic metres in volume.

2.2.8 BLASTING:

No guarantee is given or implied that blasting shall be accepted but should this method of removal be necessary and permitted, the Contractor must take all responsibility and observe all conditions set forth in all Government and Local Authority Regulations and/or bylaws.

2.2.9 EXCAVATED MATERIAL SUITABLE FOR REPLACING OVERBREAK IN EXCAVATIONS FOR FOUNDATIONS

The backfill in overbreak for foundations shall be capable of sufficient compaction to avoid settlement and shall be capable of placement without significant voids.

The backfill shall not contain appreciable quantities of organic matter or stones of average dimension exceeding the lesser of 150 mm or two-thirds of the thickness of the layer being compacted. In addition, the backfill shall be graded material that has a PI not exceeding 10 and a CBR of at least 10 % at the minimum specified density compacted at OMC.

2.2.10 EXCAVATED MATERIAL SUITABLE FOR BACKFILL OR FOR FILL AGAINST STRUCTURES.

The following materials shall, unless otherwise specified, shall be suitable for backfill against structures:

- a) material with a CBR of at least 3 % at the minimum specified density (compactd at OMC) and a PI not exceeding 18; or

- b) hard material or rock material with a maximum dimension of 300 mm; or
- c) both clay or clayey material of a liquid limit that exceeds 40, or PI that exceeds 18 (or both), and rocks or boulders that have a maximum dimension greater than 300 mm, provided that they
 - 1) are not placed against structures, and
 - 2) are placed in predetermined quantities and in specified parts of the fill, in accordance with the requirements of 4.2.5.1; or
- d) materials that can be compacted so as to avoid settlement that exceeds 2 mm/m of depth of excavation, and that contain no more than 10 % rock or hard fragments retained on a sieve of nominal aperture size 50 mm and that contain no large clay lumps that break up under the action of the compaction equipment used.

2.3 DISPOSAL OF EXCAVATED MATERIAL

2.3.1 PART RETURN:

Material from the excavations, after testing by an approved Laboratory, where suitable and approved by the Engineers Representative, is to be returned, filled in and rammed against foundation walls, under floors, steps, etc. as necessary.

No clay shall be used as filling.

2.3.2 DEPOSIT ON SITE:

The excess material shall be deposited on site, spread and roughly levelled, where permitted by the Engineers Representative.

2.3.3 CART AWAY:

Surplus material is to be carted away to a suitable dumping site to be found by the Contractor, outside the boundary of the Site. Spoil heaps shall be flattened to present a neat level or graded surface.

2.3.4 BACKFILLING OF EXCAVATIONS AND BACKFILLING OR FILLING AGAINST STRUCTURES

Where filling is to be placed against or around a structure, such filling (whether it be backfilling or embankment) shall be placed and compacted simultaneously on both sides of the structure to minimize unequal loading.

All excavations outside structures shall be carefully refilled with material that complies with 2.2.9, in layers of thickness not exceeding 250 mm before compaction.

During the placing of each layer, the filling shall be well rolled and compacted, and sufficient water shall be added uniformly to ensure that the density specified for that particular zone is achieved or, where a density is not specified, that the density achieved is at least that of the adjoining undisturbed material. Each layer shall be completed before the next layer is added.

2.4 MAINTENANCE OF EXCAVATIONS

2.4.1 PLANKING, STRUTTING, ETC.:

Planking, strutting, shoring and temporary sheet piling shall be measured as such only when prescribed.

2.4.2 RISK OF COLLAPSE:

The Contractor shall maintain all excavated faces exceeding 1,5m deep in accordance with Government Regulations and all excavated faces not exceeding 1,5m deep affecting the safety of work and/or the workmen.

The Contractor shall carry the risk of collapse of excavated faces whether or not he takes any precautions, the nature of which shall be entirely at his own discretion.

2.5 WATER IN EXCAVATIONS

No water shall be allowed to accumulate in any portion of the excavations.

The excavations shall be protected against any water entering them whether by seepage, rains, storms, floods or any other means. Any water found in the excavations shall immediately be removed by pumping or baling.

It is the Contractor's responsibility to keep foundations and excavations water free and the Contractor must supply all pumps etc. that may be necessary for clearing out the water. Water must be cleared in such a way that it cannot seep or flow back into the excavations.

2.6 COMPLETION OF EXCAVATIONS

The Contractor shall give notice, in writing, to the Engineers Representative when the excavations are ready to receive the foundations.

The foundations shall not be laid until the excavations have been approved of, in writing, by the Engineers Representative and they shall not be covered until any variation has been measured.

2.7 FILLING

Filling shall be of approved clean earth in layers not exceeding 150 mm thick, well watered, rammed and consolidated to at least a density of 90% Modified AASHTO (American Associations of State Highway and Transportation Officials), which will be verified by the Engineers Representative having it tested.

All filling material shall be approved beforehand by the Engineers Representative prior to placement. A 60kg sample of the proposed fill is required for this purpose and fourteen days must be allowed for initial sample testing.

Before filling is placed the virgin soil shall be scarified and compacted to at least 90% Modified AASHTO. Each layer of fill must be tested and approved by the Engineers Representative before the next layer is placed and compacted.

a) To defined levels:

The ground outside the building shown shall be made up with earth filling as above, finished level or graded to falls as shown on the drawings, or as directed.

b) To foundations etc.:

Filling to foundations etc. shall be of earth filling as above.

The filling of areas under solid floors shall be carried out as soon as the foundations and foundation walls have been completed.

c) Thicknessess of compacted material:

Given thickness are those for compacted material.

The Engineers Representative shall keep notes on all filling supplied by the Contractor.

d) Descriptions (prices):

Descriptions (prices) of all filling including filling supplied by the Contractor from an off-site source, and separately measured, are to include for any necessary stockpiling and multiple handling.

2.8 SURPLUS EARTH

All surplus earth, topsoil and/or other materials from excavations shall be deposited and levelled on the site, or carted away, as directed.

2.9 GRAVEL DRESSING

Gravel dressing to the ground outside the building shall be of approved clean gravel, well watered and consolidated by rolling with an approved roller to a hard even surface. The dressing shall be of a consolidated 75mm thickness.

2.10 FINISHING

Final grading

On completion of earthworks to the finished level and of backfilling of all holes, trenches, etc., the whole surface shall be graded, shaped and compacted to final grades and levels.

Topsoiling

On completion of earthworks to the finished level and of backfilling of holes, trenches, etc., the whole surface shall be graded, shaped and compacted to final grades and levels.

Topsoil shall be placed on level and slightly graded areas and shall be lightly compacted by wheeled vehicles or by tamping, and trimmed neatly to the required lines, grades and levels. The final thickness of the topsoil after compaction shall be at least 75 mm.

Where required or directed by the Engineers Representative, grass or other vegetation shall be planted after topsoiling has been completed. On completion of planting, the planted area shall be neatly trimmed and well watered and not allowed to dry out until it is established.

Grass or other vegetation

Where required in terms of the specification data, grass or other vegetation shall be planted after topsoiling has been completed. On completion of planting, the planted area shall be neatly trimmed and well watered and not allowed to dry out until it is established, or for the period required in the scope of work.

Reinstatement and maintenance of roads

Roadways through which trenches or other excavations have been made shall be reinstated and maintained. The road surface shall be restored to its correct level without any subsidence occurring at the site of such trench or other excavation.

2.11 EARTH WORKS FOR PIPELINES

Applicable standard: SANS 2001 – Construction Works Part DP1: Earthworks for buried pipelines and prefabricated culverts.

This part of SANS 2001 covers earthworks for trenches for all types and sizes of buried pipelines, ducts, cables and prefabricated culverts, including excavation, preparation of trench bottoms, bedding, backfilling and reinstatement of surfaces.

2.11.1 MATERIALS

2.11.1.1 SELECTED GRANULAR MATERIAL

Selected granular material shall, unless otherwise specified in the scope of work, be material of a granular, non-cohesive nature that is free-draining, has a maximum aggregate size of 20 mm and has a compaction fraction that does not exceed 0,3.

2.11.1.2 SELECTED FILL MATERIAL

Selected fill material shall, unless otherwise specified in the scope of work, be material that has a PI that does not exceed 6 and that is free of vegetation, lumps and stones the largest dimension of which does not exceed 30 mm.

2.11.1.3 FINE GRANULAR MATERIAL

Selected fill material all of which passes through a 6,70 mm sieve and not more than 10 % of which passes through a 0,15 mm sieve.

2.11.1.4 CONCRETE

Concrete shall, unless otherwise specified in the scope of work, be grade 20 or higher and shall comply with the requirements of SANS 2001-CC1 or SANS 2001-CC2.

2.11.2 BACKFILL MATERIAL

Material excavated from trenches and used as backfill shall

- e) contain little or no organic material,
- f) exclude stone the average dimension of which exceeds 150 mm, and
- g) be able to be placed without significant voids and be so compacted as to avoid significant settlement.

Such material shall contain not more than 10 % of rock or hard fragments that are retained on a sieve of nominal aperture size 50 mm, and shall not contain large clay lumps that do not break up under the action of compaction equipment.

In areas subjected to loads from road traffic and in other areas specified in the specification data (see annex A), backfill shall have a PI that does not exceed 12 and a minimum CBR of 15 % at specified density if the backfill is to be placed in the upper 150 mm of the subgrade, and a minimum CBR of 7 % if the backfill is to be placed lower in the subgrade.

2.12 METHODS AND PROCEDURES

2.12.1 PREPARATORY WORK

2.12.1.1 SITE CLEARANCE

An area of sufficient width along the route of the excavation shall be cleared in accordance with the requirements of SANS 2001-BS1 to ensure that selection operations are not hampered.

Where trenches are in servitudes or wayleaves of specified width, clearing and damage to plant growth shall be restricted to the servitude or wayleave area.

2.13 EXCAVATION

2.13.1 METHOD OF EXCAVATION

In order to produce material suitable for the bedding, selective methods of excavation may be used, or the excavated material may be screened, washed or otherwise treated.

Hard rock and boulders from excavations may be incorporated in the backfill provided that such material is suitably mixed with other backfill material and the required compaction is achieved.

Excavated material shall not be wastefully disposed of. Positive steps shall be taken to avoid burying or contaminating materials that would otherwise be suitable for use as

- a) selected fill for the blanket or selected granular material for the cradle, unless other materials have been specified in the scope of work, or
- b) topsoil, or
- c) road materials for reuse.

When otherwise suitable material from a trench is contaminated, any shortfall may be made up by obtaining suitable material from other excavations on the site, or by opening up borrow pits, or by importing from commercial or other sources.

2.13.2 SIZE OF EXCAVATION

Trenches shall be excavated in suitable lengths, to widths that, in each case, provide at least the appropriate side allowances (within trench supports and wales, if any) given in 12.13.3 or the scope of work, and such that half of the specified base width is on either side of the designated centre line of the pipeline or culvert. The sides of each trench from the bottom up shall be as nearly vertical as possible for at least the height of the bedding.

2.13.3 MINIMUM BASE WIDTH

The widths of excavations shall be sufficient to allow the proper laying, bedding and backfilling of pipelines and prefabricated culverts.

Unless otherwise specified in the scope of work, the base width of a trench (W) (see figure 1) shall be not less than the external diameter of the pipe barrel plus twice the side allowance determined from table 1.

Where two or more pipes are to be placed in one trench, the base width of the trench shall be not less than the sum of the external diameters of the pipe barrels plus the side allowance for each outer pipe plus, between each pair of adjacent pipes, the average of the side allowance for each pipe.

The minimum base width for pipes of external diameter that does not exceed 125 mm and laid at a depth that does not exceed 1,5 m may be less than 600 mm for flexible continuous piping that, in terms of the scope of work, requires no bedding or jointing in the trench.

2.13.4 MAXIMUM BASE WIDTH

Unless otherwise specified in the specification data or elsewhere in the scope of work, the base width shall not exceed the minimum base width specified in 2.13.3 by more than 50 %.

2.13.5 PILOT TRENCHING

Where indicated in the scope of work or site information that underground services either cross or are located adjacent to the pipeline or prefabricated culvert that is to be constructed, such services shall be exposed by hand ahead of trenching operations to enable any changes that might be needed in the design of the pipeline to be made timeously. Care shall be taken in exposing such services to avoid damaging them.

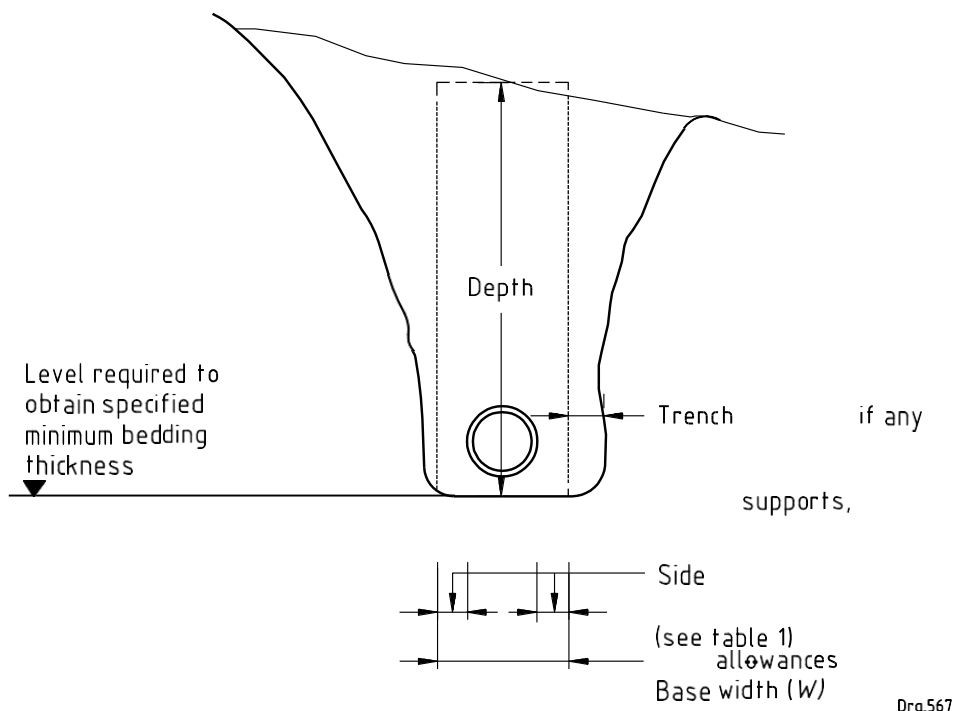

Drg.567

Figure 1 — Base trench width
PD Table 1 — Side allowances

1	2
External diameter of pipe barrel (<i>D</i>) mm	Side allowance on either side mm
≤ 700	300
701 – 1 000	400
1 001 – 2 000	500
> 2 000	600

2.13.6 TRENCH BOTTOM

The depth of the trench shall be such that the specified depth of the cradle can be placed under the pipeline or prefabricated culvert, if any, and the trimming and grading of the bottom of the trench shall be such that the barrel of each length of pipe can be uniformly supported over its full length, free at the joints, and at the correct grades and levels. Except where the trench excavation is in rock, hard objects and boulders that might adversely affect the uniformity of the foundation shall be removed to a depth of 100 mm below the specified trench bottom. Where the bottom of the trench has been loosened during excavation, it shall be compacted at OMC to 90 % of modified AASHTO maximum dry density before bedding and pipe laying or culvert placement.

Material that is unsuitable as the bottom of a trench shall be excavated and the trench shall be refilled with suitable material and compacted to 90 % modified AASHTO maximum dry density.

Any over-excavation of the trench shall be backfilled with selected fill material and compacted to 90 % modified AASHTO maximum dry density.

The bottom of trenches shall be sufficiently straight (or true to alignment in the case of curved pipelines) to enable the pipelines or prefabricated culverts to be laid without reduction of the side allowances given in 2.13.3 or the scope of work.

The trench bottom shall be kept sufficiently free from water to enable the bedding to be placed.

2.14 BEDDING FOR PIPES

2.14.1 GENERAL

Pipes shall be bedded and protected in accordance with the details shown in the following figures, as required in terms of the scope of work:

- a) figure 2 for rigid pipes; and
- b) figure 3 for flexible pipes.

NOTE Rigid pipes support vertical loads primarily by virtue of their resistance as a ring to bending or deformation. Flexible pipes rely primarily upon side support to resist vertical loads without excessive deflection.

Except in the case of class A bedding, the joint holes shall be refilled with fine granular material and lightly compacted to prevent the migration of adjacent pipe bedding material into the holes and to obviate the production of hard spots under joints (see figure 4).

In the placing of bedding, all voids under the overhang of the pipes shall be filled and the compaction shall be carried out uniformly on either side of the pipeline so as not to cause any lateral or vertical displacement of the pipes.

Bedding shall be carried out as pipe laying proceeds, and shall be completed before construction testing is carried out.

2.14.2 CLASS A BEDDING

Where class A bedding (see figure 2(a)) is required in terms of the scope of work, the pipes shall be supported on a continuous cradle of concrete that has a 28 d characteristic compressive strength of 20 MPa. During pipelaying and before the placing of the concrete bedding, the pipes shall be suitably supported after the casting of a blinding layer so that alignment is maintained (see figure 5(a)).

Each length of bedding shall be placed in one continuous operation. The concrete shall extend across the full base width for pipes up to 600 mm in diameter and shall be cast against forms where pipes are larger than 600 mm in diameter and the trench bottom exceeds the base width of the trench determined in accordance with 2.13.3 (see figure 6).

Care shall be taken during the placement of the concrete to prevent movement or flotation of the line. In the case of pipes with flexible joints, concrete shall not be allowed to enter the joints during construction of the bedding, and a positive vertical movement joint in the cradle shall be formed at each pipe joint.

The selected fill blanket shall not be placed in any section until a period of 24 h has elapsed after placement of the cradle in that section. The backfill shall not be placed in any section until the cradle in that section has achieved a compressive strength of at least 15 MPa.

2.14.3 CLASS B BEDDING AND CLASS C BEDDING

Where class B bedding (see figure 2(b)) and class C bedding (see figure 2(c)) are required in terms of the scope of work,

- a) the pipes shall be bedded on a continuous bed of selected granular material,
- b) the material shall be placed in accordance with the details shown in figures 2(b) or 2(c), as relevant, and
- c) the bedding shall be constructed in the manner shown in figures 5(b) or 5(c), as relevant. To ensure that each pipe is fully supported throughout the length of its barrel on the cradle, joint holes shall be formed in the cradle for pipe sockets and couplings.

2.14.4 CLASS D BEDDING

Where class D bedding (see figure 2(d)) is required in terms of the scope of work, the pipes shall be placed directly on the trench bottom after this has been hand-trimmed to ensure that each pipe is fully supported throughout the length of its barrel. Joint holes shall be formed in the trench bottom for pipe sockets and couplings.

2.14.5 TEMPORARY SUPPORT MATERIAL (CLASS B, C, AND D BEDDING)

Any material that is used to support a pipeline temporarily during construction, or that does not comply with the requirements for the cradle, shall be removed before the selected fill blanket for class B, C, or D bedding is placed.

2.14.6 BEDDING FOR FLEXIBLE PIPES

2.14.6.1 CRADLE

Flexible pipes shall be supported on a continuous bed of selected granular material of compacted depth at least 100 mm and that covers the full width of the trench. The granular material shall be compacted to the density specified in 2.14.6.3. Additional selected granular material shall then be placed carefully and evenly between the sides of the trench and the pipeline, in layers of uncompacted thickness approximately 100 mm, as shown in figure 3 and in accordance with the construction details shown for flexible pipes in figure 5(d). Each layer shall be compacted individually to the density specified in 2.14.6.3. Particular care shall be exercised to prevent damage, deflection, or displacement of the pipeline.

2.14.6.2 200 MM SELECTED FILL BLANKET

After completion of the cradle, a 300 mm selected fill blanket shall be placed carefully in layers of 100 mm uncompacted thickness over the full width of the trench and shall be compacted to the density specified in 2.14.6.3 up to a height of at least 300 mm above the crown of the pipeline. Special care shall be taken when compacting over the pipeline.

2.14.6.3 COMPACTION

The degree of compaction attained for bedding (other than concrete and the material over the top of the pipeline) shall be 90 % of modified AASHTO maximum dry density.

2.14.6.4 CONCRETE CASING TO PIPES

Where shown in the drawings or required in terms of the scope of work, pipes shall be encased in concrete. The lower part of the encasement shall be constructed first, in the manner specified for class A bedding in 2.14.2. Once the pipeline has been tested and found to comply with the requirements, the pipes shall be covered with concrete to the specified depth, and movement joints shall be constructed in the upper part to coincide with those in the lower part. No earthfilling over the concrete shall be commenced until at least 2 d after the concrete has been placed, or until the concrete has attained a strength of at least 15 MPa.

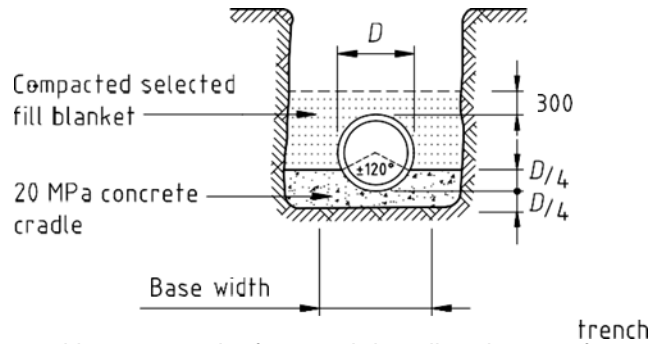

300mm max. with 100mm min. for trench in soil and 50mm for trench in rock

Fig 2 (a) Rigid pipe on Class A bedding

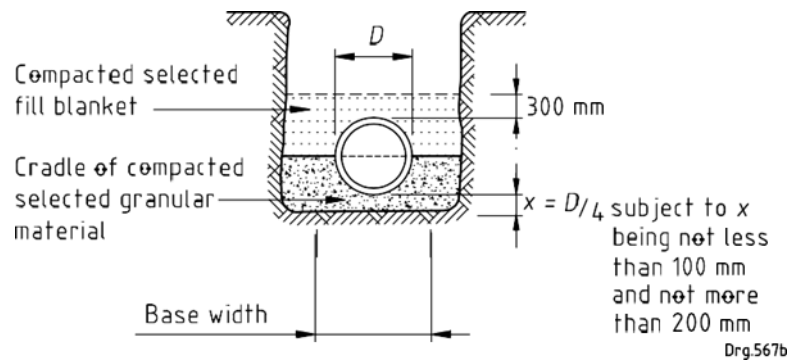
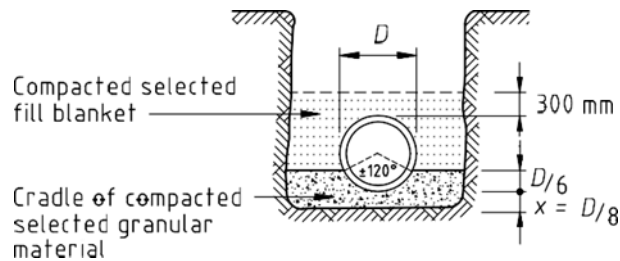
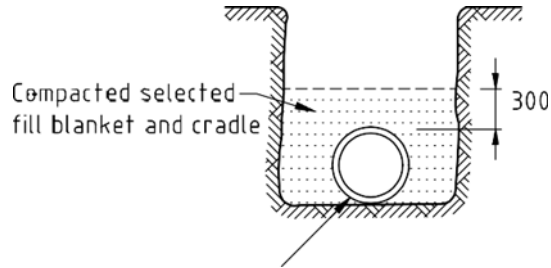

Fig 2 (b) Rigid pipe on Class B bedding



Subject to x being not less than 100mm and not mor than 200mm

Fig 2 (c) Rigid pipe on Class C bedding



Trench bottom shall be hand trimmed to support the pipe throughout the length of its barrel.
Pipes shall not rest on their sockets or collars.
Joint holes shall be cut in the trench bottom.

Fig 2 (d) Rigid pipe on Class D bedding

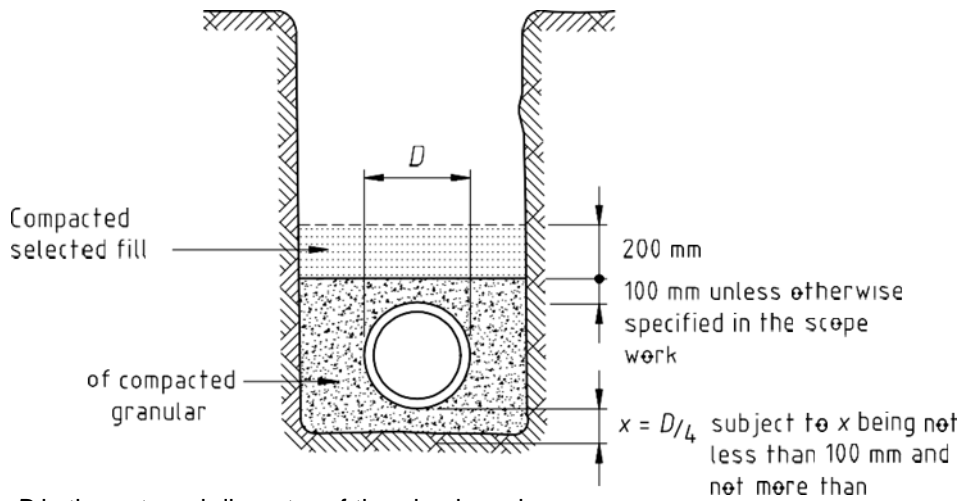

NOTE D is the external diameter of the pipe barrel

Figure 3: Flexible pipes

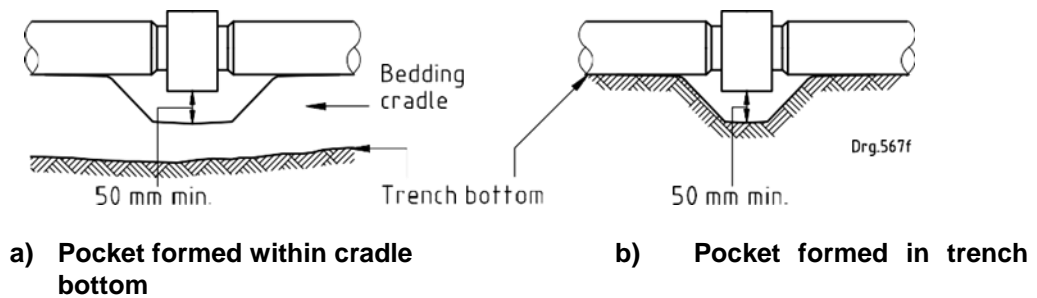

Figure 4: Typical joint pockets

Backfill

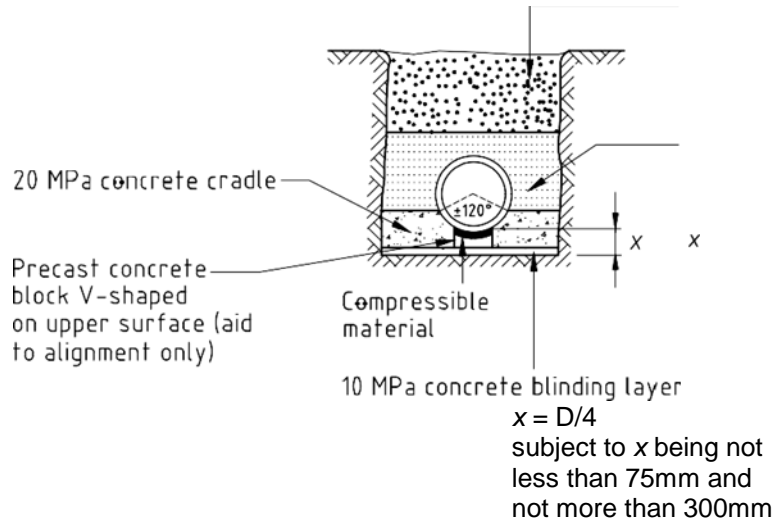

Figure 5 (a): Class A bedding

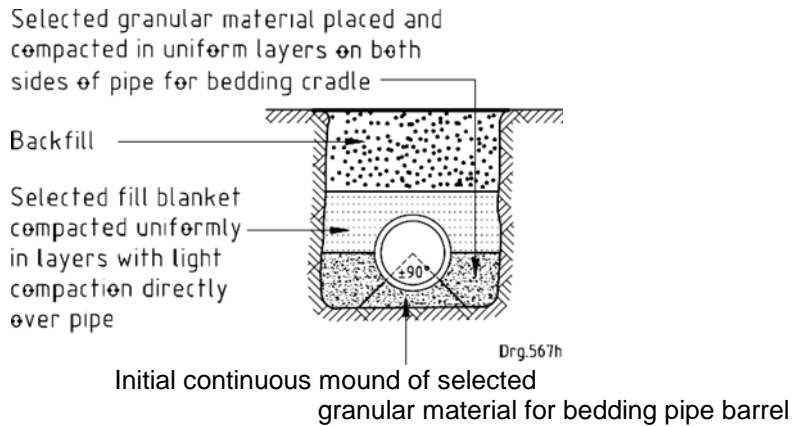

Figure 5 (b): Class B bedding

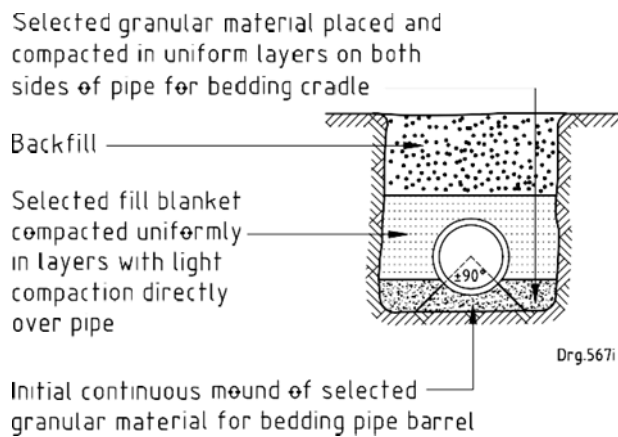

Figure 5 (c): Class C bedding

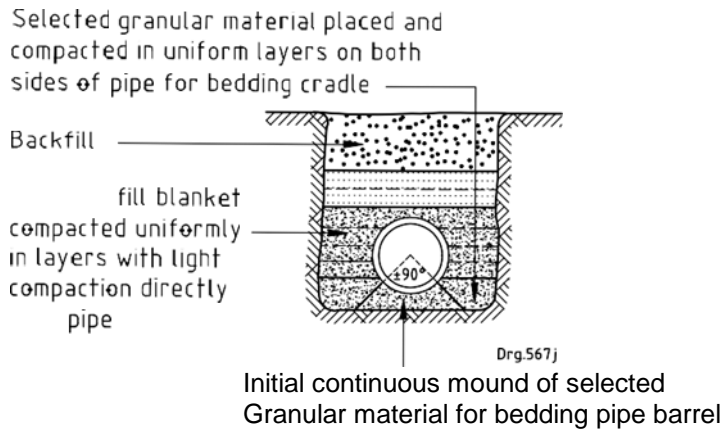

Figure 5 (d): Flexible pipe supported on selected granular material

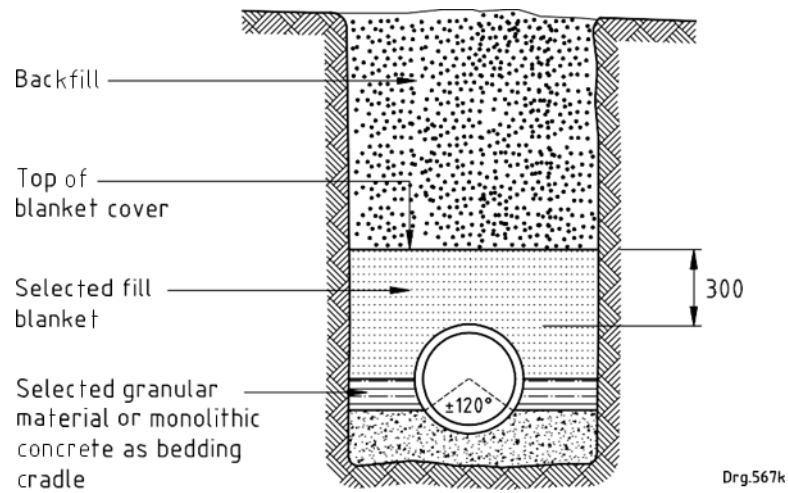

Figure 6 (a): Backfilling over rigid pipeline

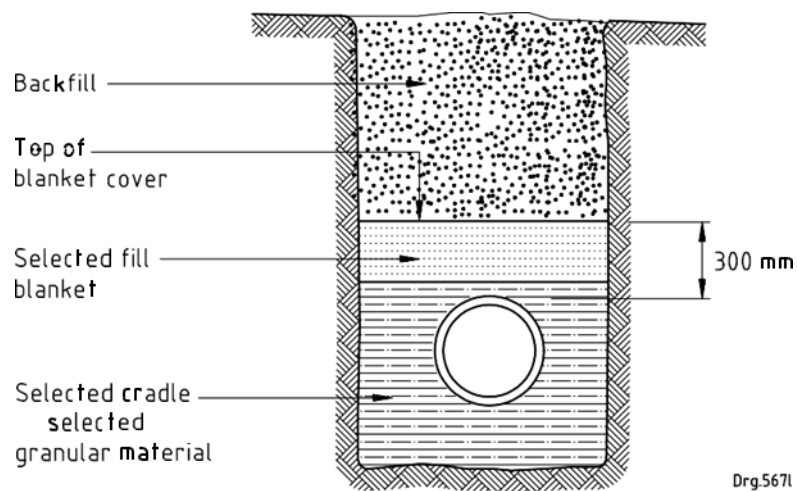

Figure 6 (a): Backfilling over flexible pipeline

2.15 BACKFILLING

2.15.1 GENERAL

Backfilling of trenches shall commence after the pipe has been laid and firmly bedded in the specified cradle and the blanket has been placed and suitably compacted at OMC around and over the top of the pipe to the height of the blanket cover specified in the scope of work (see figure 6).

Backfilling shall be carried out over the full extent of the actual trench excavation and to original ground level. No filling shall be placed in water.

2.15.2 MATERIAL FOR BACKFILLING

Material for backfilling above the bedding (cradle and blanket) shall be obtained from trench excavations. Hard material and rock material shall not be incorporated in the backfill unless suitably mixed with other backfill material.

2.15.3 DISPOSAL OF SOFT EXCAVATION MATERIAL

Excavation material from the trench, which is unsuitable or has become surplus, shall be disposed of along the trench servitude, unless otherwise required in terms of the specification data.

2.15.4 DISPOSAL OF HARD MATERIAL AND ROCK MATERIAL

Where the quantity of hard material or rock material exceeds that which can be or is required to be incorporated in the backfill, the surplus shall be disposed of as specified in 4.2.5.3, or removed to sites specified in the scope of work.

2.15.4 DEFICIENCY OF BACKFILL MATERIAL

Any deficiency of backfill material from trench excavations because of the removal of excessive quantities of organic material or clay, unsuitable parts of the trench bottom, or excessive quantities of hard rock material, shall be made up from suitable surplus material from other excavations on the site or from imported material.

2.15.5 COMPLETION OF BACKFILLING

Backfilling of trenches shall be completed expeditiously and in reasonable lengths.

2.15.6 TRENCHES IN ROAD RESERVES AND PAVED AREAS

Where trenches are situated in road reserves or paved areas, the road surface or paved area (as applicable) adjacent to the trench shall be cleaned.

2.16 COMPACTION

2.16.1 AREAS NOT SUBJECTED TO TRAFFIC LOADS

Except as specified in 2.15, each trench shall be backfilled in layers of thickness (after compaction) that do not exceed 150 mm and the material shall be compacted to the same density as that of the undisturbed surrounding ground, or to 90 % of modified AASHTO maximum dry density, whichever is the higher.

2.16.1 AREAS SUBJECTED TO TRAFFIC LOADS

In areas subjected to road traffic loads and in such other areas as specified in the specification data (see annex A), trenches shall be backfilled in layers of thickness (after compaction) that do not exceed 150 mm and the material shall be compacted to 93 % of modified AASHTO maximum dry density in the case of cohesive soil, or 98 % in the case of non-cohesive soil.

NOTE It is extremely difficult to compact a layer in excess of 100 mm to the required density with walk-behind rollers. Where a 150 mm layer is required, it should be compacted in two 75 mm layers

2.17 REINSTATEMENT OF SURFACES

2.17.1 WIDTH TO BE REINSTATED

In all cases, the reinstatement of surfaces over the full extent of the top of the actual excavation shall comply with the applicable requirements given in 2.17.2 (inclusive).

Where a pipe trench crosses a surfaced road or paved area or runs along the edge of such a road or area, the total actual excavation, regardless of the base width as determined in terms of 2.17.3.

2.17.2 PRIVATE PROPERTY AND COMMONAGE

The top 300 mm layer of each trench that will not be subjected to road traffic loads shall be of such topsoil as is available in addition to soft material from excavations. The finished surface of backfilling that is left proud of the surrounding ground to allow for initial settlement shall be not more than 150 mm above the surrounding ground level. Any settlement below original ground level that occurs shall, as soon as is practicable, be made good with material of the same quality as that adjacent to the trench, except as otherwise required in terms of the specification data.

2.17.3 GRAVEL ROADS

Immediately after completion of the backfilling to the top of the subgrade level of a trench that crosses or runs along a gravel road, the road surface shall be reinstated by filling the remainder of the trench with a suitable well-graded and well-compacted hard-wearing gravel surface of thickness at least 150 mm and of quality equal to that of the existing road surface. The gravel layer may be finished with a slight camber in order to allow for initial settlement but, particularly where the new gravel surface is transverse to the flow of traffic, it shall not be left so far proud of the adjacent road surface as to cause excessive jolting of any vehicle proceeding at normal speed.

2.18 DAMAGE TO ROAD SURFACES

Where, during the execution of the works, any road or paved surface adjacent to a trench has been damaged in any way whatsoever by the construction equipment, such surface shall, as soon as is practicable, be repaired to a condition at least equivalent to that previously existing.

2.19 TESTING

2.19.1 MATERIAL PROPERTIES OF BEDDING AND FILL MATERIAL

The material properties of bedding and fill materials shall be determined in accordance with the requirements of TMH1-A3, TMH1-A7, and TMH1-A8, as relevant.

2.19.2 IN-PLACE DRY DENSITY AND MOISTURE CONTENT

The in-place dry density of the bedding and fill shall be determined in accordance with the requirements of TMH1-A10(a) by means of the sand replacement method, or where appropriate, by nuclear methods in accordance with the requirements of TMH1-A10(b).

The moisture content shall be determined in accordance with the requirements of TMH1-A7 where the sand replacement method is used and TMH1-A10(b) where nuclear methods are used.

2.19.3 TESTING BY MEANS OF A DYNAMIC CONE PENETROMETER

As an alternative to 2.19.2, unless otherwise specified in the specification data and provided that the bedding or fill does not comprise more than 10 % gravel of size less than 10 mm and contains no isolated boulder, the fill shall be deemed to comply with the requirements where the rates of penetration determined in accordance with TMH6-ST6 are in accordance with the requirements of table 2.

WARNING A dcp shall be used with care so as not to damage the pipe coatings or the pipes themselves.

Table 2 — Rates of penetration

1	2
Material	Maximum dcp penetration mm/blow
Bedding	14
Selected fill blanket	14
Backfill (areas not subjected to traffic loads)	14
Backfill (areas subjected to traffic loads)	17

2.19.4 COMPACTION FRACTION

The compaction fraction shall be determined, using a 250 mm long open-ended cylinder with a bore of diameter approximately 150 mm long, a metal rammer 40 mm in diameter and weighing 1 kg, and a measuring rule graduated in millimetres, in the following manner:

- a) Obtain a representative sample more than sufficient to fill the cylinder.
- b) Place the cylinder on a firm, flat surface and put the sample into the cylinder, loosely and without tamping, until it is overfilled.
- c) Strike off the top surface of the material level with the top of the cylinder and remove the surplus material.
- d) Lift the cylinder clear of its contents and place on a clean area of the work surface.

- e) Place about one quarter of the material into the cylinder and tamp until no further compaction is obtained.
- f) Repeat for the remaining quarters, ensuring that the final surface is as level as possible.
- g) Measure down from the top to the compacted material and express this measurement as a fraction of 250 mm to give the compaction fraction.

The compaction fraction for selected granular material may be less than, but shall not exceed, the nominated value.

2.20 TOLERANCES

2.20.1 ALIGNMENT AND GRADE

The deviation from the specified level of the trench invert and base dimensions up to a height equal to at least the diameter of the pipe or duct, as applicable, shall be such that the pipe may be laid and bedded in the trench within the tolerances specified for the pipeline.

2.20.2 MOISTURE CONTENT AND DENSITY

The permissible deviations from OMC and density in the construction of the pipe bedding material shall, except where otherwise specified in the Particular Specification.

The permissible deviations from OMC and density in the backfill shall, except where otherwise specified in the specification data, be as given in table 4.

Table 3 — Permissible deviations in the placement of pipe bedding

1	2
Item	Permissible deviation pd %
OMC in field during compaction	-2, +1
Specified density when bedding rigid pipes	0, +5
Specified density when bedding flexible pipes	0, +3

Table 4 — Permissible deviations in respect of moisture content and density

1	2
Item	Permissible deviation pd %
OMC in fill during compaction	+2, -2
Specified density	no top limit, 0

2.20.3 DYNAMIC CONE PENETROMETER READINGS

A lot shall have 75 % of the dcp penetration rates below the penetration rates given in table 2, and no result shall exceed these values by more than 5 %.

2.20.4 COMPACTION FRACTION

The compaction fraction for selected granular material may be less than, but shall not exceed, the nominated value.

PC 2 MEASUREMENT AND PAYMENT

SITE CLEARING

Item	Unit
PC 2.1 Site Clearing	square metre (m ²)

The unit of measurement shall be the square metre for the area cleared before construction could commence.

The tendered rates shall include full compensation for all labour and plant for the clearing of the Site to get it to an acceptable working terrain.

EARTH WORKS GENERAL

Item	Unit
PC 2.2 Remove topsoil to nominal depth of 150 mm and stockpile	square metre (m ²)

The unit of measurement shall be the square metre of topsoil removed to a nominal depth of 150 mm, stockpiled and maintained.

The tendered rates shall include full compensation for all labour and plant for the removal of topsoil to a nominal depth of 150 mm, stockpile and maintain as directed by the Engineers Representative.

Item	Unit
PC 2.3 Cut to fill: Compact to 90% mod. AASHTO max. density.....	cubic metre (m ³)

The unit of measurement shall be the cubic metre for the excavation for cut to fill and compacted to 90% mod. AASHTO maximum density.

The tendered rates shall include full compensation for all labour and plant for the cut to fill and compaction of fill material to a maximum density of 90% mod. AASHTO as indicated on the drawings or as directed by the Engineers Representative and the stacking of the surplus excavated material for later use.

Item	Unit
PC 2.4 Compacted filling material supplied by the Contractor.....	cubic metre (m ³)

The unit of measurement shall be the cubic metre for the G5 filling material selected and supplied by the Contractor from a approved source, deposited, watered and consolidated to 95% Modified AASHTO density in layers not exceeding 150mm thick base course under floors, etc.

The tendered rates shall include full compensation for all material, labour and plant for the depositing and compaction of selected filling material into the works.

Item	Unit
-------------	-------------

PC 2.5 Excavate in earth for surface trenches.....cubic metre (m³)

The unit of measurement shall be the cubic metre for the excavation in earth for surface trenches not exceeding 2000mm deep.

The tendered rates shall include full compensation for all labour and plant for the excavation of trenches to the specified depth as indicated on the drawings or as directed by the Engineers Representative as well as for keeping the excavations free from water.

PC 2.6 Extra over for excavate in earth for surface trenches exceeding 2000mm deep.....cubic metre (m³)

The unit of measurement shall be the cubic metre for the excavation in earth for surface trenches exceeding 2000mm deep.

The tendered rates shall include full compensation for all labour and plant for the excavation of trenches to the specified depth as indicated on the drawings or as directed by the Engineers Representative as well as for keeping the excavations free from water.

Item **Unit**

PC 2.7 Extra over for excavations in soft rock for surface trenches ...cubic metre (m³)

The unit of measurement shall be the cubic metre for the excavation in soft rock for surface trenches not exceeding 2000mm deep.

The tendered rates shall include full compensation for all labour and plant for the excavation of trenches to the specified depth as indicated on the drawings or as directed by the Engineers Representative as well as for keeping the excavations free from water.

Item **Unit**

PC 2.8 Extra over for carting surplus excavated material..... cubic metre (m³)

The unit of measurement shall be the cubic metre for carting away of the excavated material that shall not be used for the backfilling for the base of the floors.

The tendered rates shall include full compensation for all labour and plant for the carting away of the surplus excavated material to a designated site as directed by the Engineers Representative.

Item **Unit**

PC 2.9 Extra over for prescribed density tests on filling..... Number (No.)

The unit of measurement shall be the number of density tests executed to determine the compaction density of the backfilled material.

The tendered rates shall include full compensation for all labour and plant for the taking of samples, testing at an approved laboratory and the provision of detailed test results of the compacted filling as directed by the Engineers Representative.

Item **Unit**

PC 2.10 Excavate in all materials and backfill Cubic metre (m³)

The unit of measurement shall be the cubic metre of excavation of holes and the placing and compacting of excavated material in layers of 150 mm to mod. AASHTO 90% maximum density.

The tendered rates shall include full compensation for all labour and plant for the excavation of holes to the specified depth as indicated on the drawings or as directed by the Engineers Representative as well as for keeping the excavations free from water. The back filling of excavated materials to fix the fence posts and the compaction thereof in layers not exceeding 150 mm to 90% mod. AASHTO maximum density

PC 2.11 Extra over for excavate in intermediate material and backfill ..Cubic metre (m³)

The unit of measurement shall be the cubic metre of excavation of holes in intermediate material and the placing and compacting of excavated material in layers of 150 mm to mod. AASHTO 90% maximum density.

The tendered rates shall include full compensation for all labour and plant for the excavation of holes to the specified depth as indicated on the drawings or as directed by the Employer’s Agent Representative as well as for keeping the excavations free from water. The back filling of excavated materials to fix the fence posts and the compaction thereof in layers not exceeding 150 mm to 90% mod. AASHTO maximum density

Item **Unit**

PC 2.12 Gravel dressing of consolidated 75 mm thickness... Cubic metre (m³)

The unit of measurement shall be the cubic metre of gravel dressing to the ground outside the building of approved clean gravel, well watered and consolidated by rolling with an approved roller to a hard even surface. The dressing shall be of a consolidated 75mm thickness.

The tendered rates shall include full compensation for all labour, material and plant for the supply to site, spreading of selected gravel dressing to the ground outside the building as shown on the drawings or as directed by the Engineer of approved clean gravel, well watered and consolidated by rolling with an approved roller to a hard even surface. The dressing shall be of a consolidated 75mm thickness.

EARTH WORKS FOR PIPELINES

Item **Unit**

PC 2.13 Clearing the pipe line 2m wide strip (m)

The unit of measurement for clearing the fence line shall be the metre of fence line measured along each fence line.

The tendered rate shall be in full compensation for clearing the fence line complete as specified in “**CLEARING THE PIPE LINE**”, including amongst others the removal of trees, stones, and other obstructions and the disposal of all waste material resulting from clearing operations, as may be directed.

The removal of trees and stumps with a girth exceeding 1 m shall be paid for as an extra over.

Only those areas designated to be cleared will be measured for payment and will be measured to the nearest 0.1 m. The removal of topsoil to a depth of 150mm from the specified area will include the stockpile of topsoil and shall be measured as in meters.

The rate shall cover the cost of removing boulders of size up to 0.15m³, backfilling of cavities, removing, transporting, and disposing of material thus cleared, grubbed and cut. Boulders over 0.15m³ will be dealt with as excavation in terms of the items scheduled for bulk excavations.

Item	Unit
PC 2.14 Excavate in all materials for trenches for various depths: ...	Cubic metre (m ³)
1. Not exceeding 1,0 m depth and 600 mm wide.	
2. Between 1,0 m and 2,0 m and 600 mm wide with sides sloped.	

The unit of measurement shall be the cubic metre of earth works for trenches for pipelines at various depths.

The tendered rates shall include full compensation for all labour and plant to excavate in all materials for trenches, backfill, compact and dispose of surplus unsuitable material.

Item	Unit
PC 2.15 Extra over for item PC 2.14 for intermediate and hard rock excavation.....	cubic metre (m ³)

The unit of measurement shall be the cubic metre of earth works for pipelines at various depths.

The tendered rates shall include the full compensation for all labour and plant to excavate in the listed materials.

Item	Unit
PC 2.16 Extra over for item PC 2.14 for excavation ancillaries	cubic metre (m ³)
1. Compaction in road reserves	

The unit of measurement shall be the cubic metre of compacted earth in road reserves.

The tendered rates shall include the full compensation for all labour and plant to compact the excavated earth to the required density in road reserves.

Item	Unit
PC 2.17 Provision of bedding from trench excavations	cubic metre (m ³)

The unit of measurement shall be the cubic metre of 300 mm x 600 mm selected granular bedding material.

The tendered rates shall include the full compensation for all labour and plant to select and prepare the granular bedding material from trench excavations.

Item	Unit
PC 2.18 Supply only of bedding from borrow pits	cubic metre (m ³)

The unit of measurement shall be the cubic metre of 300 mm x 600 mm selected granular bedding material.

The tendered rates shall include the full compensation for all labour and plant to select and prepare the granular bedding material from borrow pits.

Item	Unit
-------------	-------------

PC 2.19 Density testing of compacted bedding material	Number (No.)
---	--------------

The unit of measurement shall be the number of dynamic cone penetrometer density tests executed.

The tendered rates shall include the full compensation for all labour and plant to execute the required density tests.

3 SECTION 3: CONCRETE, FORMWORK AND REINFORCEMENT

Structural Works

Applicable standard: SANS 2001 – Construction Works Part CC1: Concrete Works (structural).

Minor Works

Applicable standard: SANS 2001 – Construction Works Part CC2: Concrete Works (minor works).

Foundations

Applicable standard: SANS 2001 – Construction Works Part CM2: Strip footings, Pad footings and Slab-on-the-ground Foundations for Masonry Walling

NB: All in situ concrete work (mass and reinforced) shall comply with SABS Specification 1200G ("8. Measurement and Payment" is **not** applicable) supplemented by the clauses in this section. Where SABS Specification 1200G and the clauses in this section are in conflict the clauses in this section shall take precedence.

Where the term "plain concrete" appears in SABS Specification 1200G it shall be read as "mass concrete"

3.1 CEMENT

Cement shall be Portland cement complying with the requirements of SABS Specification 471 or PC15 complying with SABS Specification 831.

Samples of cement from any one, or from every consignment, may be required by the Representative/Agent for test purposes. Cement in any consignment from which a sample may have been taken for testing shall not be used until it has been approved. Allowance must be made for possible delay in that tests may take 10 days to carry out.

Bags of cement shall be stacked in a waterproof, solidly constructed shed with a central door and a floor rendered damp-proof with a tarpaulin. The bags of cement shall be closely stacked (but not against walls) in order to reduce air circulation in such a manner that the cement is used in the order in which it was received, i.e. first in first out.

Unless otherwise specified in the tender documents the use of ordinary Portland cement blended with ground granulated blast furnace slag complying with SABS Specification 1491, or ordinary Portland Cement blended with Pulverised Fly Ash complying with SABS Specification 1466 will be allowed in certain instances as an alternative, after acceptance of tender, but only with the approval of and at the sole discretion of **the Department**.

3.2 SAND (FINE AGGREGATE)

The fine aggregate shall comply with the requirements of SABS Specification 1083. Other aggregates may be approved if they have a satisfactory history and/or test results.

No aggregate may be used until it has been approved. Samples having a mass of 25 kg (16,5 litre) of the aggregate proposed to be used may be required by the Representative/Agent for test purposes. Samples having a mass of 25 kg shall be forwarded every 3 months during concreting work and also if the source of supply is changed. Allowance must be made for possible delay in that the tests may take 14 days to carry out.

3.3 STONE (COARSE AGGREGATE)

The coarse aggregate shall comply with the requirements requirements of SABS Specification 1083.

No aggregate may be used until it has been approved. Samples having a mass of 25 kg (16,5 litre) of the aggregate it is proposed to use may be required by the Representative/Agent for test purposes. Samples shall be forwarded every three months during concreting work and also if the source of supply is changed. Allowance must be made for possible delay in that the tests may take 14 days to carry out.

NB: Certain fine grained sand and stone originating from the Beaufort Series and Karoo Systems which are known by reputation, local experience or tests, to exhibit excessive shrinkage when used in concrete, may be deemed unacceptable by the Representative/Agent.

A certificate of proof is required from the Contractor that the aggregates are not alkalireactive. The cost of testing and certification are to be borne by the Contractor.

3.4 WATER

The water used shall be fit for drinking.

3.5 CONCRETE

Concrete shall be of the classes given in the following table. The proportions of the ingrediants and the nominal size of the coarse aggregate for each class shall be as laid down therein, viz:

Table — Concrete mix proportions for use with 19 mm stone

0	1	2	3	4	5	6	7
Class	Grade of concrete	Cement kg	Sand		19 mm stone		Water ^b L
			L	Wheelbarrow ^{s^a}	L	Wheelbarrow ^{s^a}	
Class 42,5 N or R cement							
A	10	100 (2 bags)	290	4,5	290	4,5	72
B	15	100 (2 bags)	260	4,0	260	4,0	66
C	20	100 (2 bags)	230	3,5	230	3,5	60
D	25	100 (2 bags)	200	3,0	200	3,0	55
E	30	100 (2 bags)	160	2,5	160	2,5	51
^a A standard wheelbarrow for concrete (SANS 795 type 5 wheelbarrow) has a capacity of between 60 L and 70 L with no projection of material above the rim of the wheelbarrow. ^b Only sufficient water should be added to produce a workable mix. The quantities of water are for guidance only as the actual quantity required will depend on a number of factors, including the moisture content and quality of the sand and the type of cement used.							

Table — Concrete mix proportions for use with 13 mm stone

0	1	2	3	4	5	6	7
Class	Grade of concrete	Cement kg	Sand		13 mm stone		Water ^b L
			L	Wheelbarrows ^a	L	Wheelbarrows ^a	
Class 42,5 N or R cement							
A	10	100 (2 bags)	330	5,0	230	3,5	71
B	15	100 (2 bags)	290	4,5	200	3,0	65
C	20	100 (2 bags)	230	3,5	200	3,0	60
D	25	100 (2 bags)	200	3,0	160	2,5	56
E	30	100 (2 bags)	145	2,0	130	2,5	52
^a A standard wheelbarrow for concrete (SANS 795 type 5 wheelbarrow) has a capacity of between 60 L and 70 L with no projection of material above the rim of the wheelbarrow. ^b Only sufficient water should be added to produce a workable mix. The quantities of water are for guidance only as the actual quantity required will depend on a number of factors, including the moisture content and quality of the sand and the type of cement used.							

The strength given in the above table shall be the minimum required at 28 days.

Unless otherwise specified. Class C concrete shall be used for mass concrete and Class E concrete for reinforced concrete.

Maximum concrete slumps acceptable for different types of construction concrete are as follows:

- (a) Vibrated reinforced concrete = 50 mm
- (b) Unvibrated reinforced concrete = 75 mm
- (c) Mass concrete = 75 mm

When so required by the Employer's Agent Representative, and whilst concreting is in progress, the consistency of the mixture shall be ascertained by means of the slump test as later described herein.

3.6 VOLUME BATCHING

The coarse and fine aggregate shall be measured by volume and, unless otherwise directed, cement shall be measured by mass: the volume of a 50 kg bag of cement shall be taken as 33 litre. Suitable measuring boxes for the coarse and fine aggregates shall be provided to the approval of the Employer's Agent Representative.

The proportions given above are approximate only, and should the Employer's Agent Representative consider that the voids in the coarse aggregate require more or less matrix

than is formed by the proportions specified, he may vary the quantities of coarse and fine aggregates to obtain the required density and workability of the concrete, provided that the proportion of cement to the total volume of the aggregate shall not be less than that specified.

When the sand is not completely dry, allowance must be made for bulking due to the moisture content. The amount of bulking shall be determined by the Contractor in the presence of the Employer's Agent Representative.

The proportion of water used for mixing concrete shall be determined by the Employer's Agent Representative and once the water-cement ratio has been fixed, it shall be rigidly adhered to. On no account shall the amount of water exceed 34 litres to every bag of cement used. This figure includes the water contained in the sand.

The length of time each batch shall be mixed in the mixing machine shall be decided by the Employer's Agent Representative.

Effective screens shall be provided to protect the mixing of concrete during windy weather.

3.7 WEIGH BATCHING

The proportioning of the coarse and fine aggregates by mass will be permitted, providing the method used is approved by the Engineer.

- a) All requests received by the Representative/Agent to make use of weigh batching must be submitted to the Engineer for approval.
- b) If the weigh batching process is preferred to volume batching, the proposed mix proportions are to be equivalent to the relevant volumetric mixes as documented previously herein and be based upon a minimum cement content.
- c) The following procedures must be complied with:
 - (i) The Contractor must timeously obtain written approval for the use of weigh batching and submit all information as set out below, with his application.
 - (ii) The mix transformation from volume to weigh batching shall be carried out at an approved laboratory.
 - (iii) Weigh batching equipment must be calibrated and a certificate of accuracy must be submitted before such equipment may be used.
On contracts of long duration and/or requiring large quantities of concrete, new calibration certificates may be required every four months.
 - (iv) The cement to aggregate ratio by volume for the following mixes will apply:
Class C (15 MPa) - c/a = 1:9
Class E (25 MPa) - c/a = 1:6
 - (v) The following cement/water ratios by mass must also be complied with:
Class C (15 MPa) - c/w = 1,30 to 1,35
Class E (25 MPa) - c/w = 1,65 to 1,80

3.8 READY MIXED CONCRETE

Any application to use Ready Mixed Concrete shall be submitted by the Contractor to the Employer's Agent Representative at an early stage for approval by the Engineer. Only suppliers approved by the Engineer will be considered.

3.9 STRENGTH CONCRETE

The Contractor shall be responsible for the design of strength concrete and for the measurement of the constituent materials to produce concrete that complies with the specified requirements.

The Employer's Agent Representative will decide the class and grade designation of the concrete required for each part of the work and determines suitable limitations on the constituent materials and mix proportions in accordance with the said requirements.

(a) Trial mixes:

The Contractor must ensure that samples of the constituent materials of the concrete, together with evidence that they comply with the provisions, are supplied for approval in good time and provide the Engineer with—

- i) a statement from an approved independent laboratory of the results of tests, or
- ii) an authoritative and acceptable report, or record of the previous use of, and experience with, the material concerned.

The cement, types of aggregate and their origins may not be changed throughout the duration of the contract without giving prior notification to the Employer's Agent Representative who shall verify that the above requirements are complied with and that the important qualities of the concrete will not be impaired.

(b) Durability:

For each grade of concrete, the Employer's Agent Representative will, notwithstanding strength considerations, specify the cement/water ratio appropriate to the exposure conditions indicated in Table 5, SABS Specification 1200G, Subclause 5.5.1.5.

(c) Consistency:

Unless otherwise indicated by the general workability of the concrete, method of transportation, conditions of placement or otherwise specified by the Employer's Agent Representative, the suggested slump values, for different mixes of concrete shall be as specified in Clause 3.4.

(d) Workability:

Ensure that the concrete is of such workability that it can be readily compacted into the corners of the formwork and around reinforcement without segregation of the materials and without excessive "bleeding" of free water at the surface.

3.10 ADMIXTURES TO CONCRETE

The use of admixtures in concrete will only be considered should special circumstances warrant this and then only with the prior written approval of the Employer's Agent Representative. The Contractor shall provide the following information:

- (a) The trade name of the mixture, its source and the Manufacturer's recommended method of use.
- (b) Typical dosage rates and possible detrimental effects of both under and over dosage.
- (d) The expected average air content of freshly mixed concrete containing an admixture which causes air to be entrained when used at the Manufacturer's recommended rate of dosage.

3.11 SLUMP TEST

The apparatus and the method of determination of the slump of freshly mixed concrete shall comply with SABS STM 862.

(a) Apparatus:

- (i) A mould in the form of a frustum of a cone and having the following nominal internal dimensions:
Bottom diameter: 200 mm
Top diameter: 100 mm
Height: 300 mm

The mould shall be of a metal (other than brass or aluminium) of side thickness at least 1,6 mm and shall have a smooth internal surface.

The mould shall have suitable base plate and handles to facilitate lifting it from the test specimen in a vertical direction.

- (ii) The tamping bar shall have a nominal diameter of 16 mm, a length of 600 mm and with sharp corner rounded off at one end.

(b) Procedure:

The test shall be carried out in an area that is free from vibration and shocks.

Ensure that the internal surfaces of the mould are free from set concrete and are clean and dry.

Place the mould with the bottom on a smooth, horizontal, rigid, non-absorbent surface and hold the mould firmly in place while it is being filled as follows:

- (i) Fill the mould in four layers, each thickness approximately one-quarter of the height of the mould. Tamp each layer with 25 strokes uniformly spaced over the cross-section of the mould. Tamp the bottom layer throughout its depth and ensure that when tamping the second and subsequent layers the strokes penetrate into the underlying layer.
- (ii) After the top layer has been tamped, strike off the concrete level so that the mould is exactly filled. Clean off any concrete that may have leaked out between the mould and the supporting baseplate surface. Remove the mould from the concrete immediately by slowly and carefully raising it in a vertical direction. This will allow the concrete to subside.

Immediately measure the slump, to the nearest 5 mm, by determining the difference between the height of the mould and the height of the specimen.

If a slump specimen collapses or shears off laterally regard the test as invalid, discard the result and repeat the test.

3.12 CONCRETE TEST CUBES

The apparatus for making and testing of concrete cubes shall comply with SABS STM 863.

(a) Apparatus:

Cubic metal moulds of steel shall be machined and adequately strengthened to resist distortion. The internal distance between faces of a mould shall be 150 mm.

The mould shall be constructed so as to facilitate the easy removal without damage of the moulded specimen.

Each mould shall have a metal base plate which shall be attached to the mould by springs or screws.

When assembling the mould for use, the joints between the sections of the mould, the contact surfaces between the bottom of the mould and the base plate, and the internal faces of the assembled mould shall be thinly coated with a grease or oil that will prevent leakage of water through the joints and adhesion of the concrete to the mould.

The tamper must be a steel bar of length 400 mm and mass 1,8 kg, and having a 25 mm square ramming face.

(b) Sampling and making cubes:

Sampling shall comply with SABS STM 861.

One set of three cubes shall be required for every 40 cubic metres, or part thereof, of concrete cast.

The sample taken from a batch of concrete and sufficient to make three cubes shall be placed in a tray or on a platform and mixed thoroughly.

The moulds shall each be filled in three layers approximately 50 mm thick. Each layer shall be compacted with the tamping rod as previously specified, with at least 35 blows to give full compaction of the concrete.

After the top layer has been compacted, strike off the surface of the concrete with a trowel, level with the top of the mould.

Any small hollows shall be filled in with additional concrete. Cement/sand slurry shall not be worked into the surface.

At this stage, the identity of each sample shall be placed on the moulded cube, by means of a label of absorbent material and not by scouring of the surface of the concrete.

d) Curing cubes on site:

Cover the test cubes in their moulds with an impervious sheet or wet sacking and store indoors in a place that is free from vibration, excessive draughts, cold and direct sunlight.

After 24 hours the cubes shall be demoulded, remarked with a waterproof crayon or marker and placed in a curing tank for seven days before being transported to the laboratory.

The Contractor shall supply the curing tank which shall incorporate a thermostat to control the water temperature at 22 °C to 25 °C and shall be kept within a building.

(c) Testing of cubes:

The testing of all concrete cubes will be done by a laboratory approved by the Employer's Agent Representative in accordance with SABS STM 863.

A suitable testing machine of sufficient capacity having an accuracy and repeatability that comply with the requirements for Grade A machines of BS 1610 "Method for the load verification of testing machines" shall be used to test the compressive strength of each cube.

The Contractor is responsible for the provision of the cube moulds and for timeous delivery of the cubes to the laboratory.

3.13 CONCRETE QUALITY

Should the Contractor dispute any results obtained from concrete test cubes, the concrete represented by the cubes will be considered acceptable if the Contractor, at his own cost, proves to the satisfaction of the Employer's Agent Representative that the estimated actual strength of cores taken from the structure (by an approved independent testing laboratory and determined in accordance with SABS STM 865) is not less than the specified strength. If the concrete fails to meet the strength criteria stipulated, the Employer's Agent Representative may at his sole discretion and in addition to the options listed in SABS Specification 1200G-

- (a) accept the concrete subject to approved remedial measures being undertaken by the Contractor at his own cost; or
- (b) permit the concrete to remain, subject to reduced payment for lower strength concrete.

3.14 CONCRETING

It is essential that the foreman who has charge of the construction of all concrete work, whether reinforced or not, shall be skilled in this class of work, and shall personally superintend the whole construction, paying special regard to—

- (a) the quality, testing and mixing of the materials.
- (b) the laying of the material in place and the thorough compaction of the concrete to ensure solidity and freedom from voids;
- (c) the construction and removal of formwork; and
- (d) the sizes and positions of the reinforcement.

Particular care shall be taken to work concrete against formwork and around reinforcement. Internal vibrators may be used with the approval of the Employer's Agent Representative but external vibrators which act only on the formwork will not be permitted.

Concrete to be reinforced shall be deposited in such quantities as will permit of it being properly compacted around the reinforcement.

The placing of concrete shall be completed within half-an-hour after mixing or within half-an-hour after agitating and within 2,5 hours after mixing in the case of ready mixed concrete. On no account shall concrete be incorporated into the work after it has attained its initial set.

Care shall be taken to prevent, as far as possible, the formation of laitance or scum. Laitance is to be understood to mean the scum of strengthless and inert material which forms on the surface of concrete.

Concrete must not be dropped into position from a height greater than 2,5 m unless prior approval is obtained from the Engineer.

If an inclined chute is used for transporting concrete, it shall be of such slope as will ensure a continuous flow of concrete without the use of an excessive quantity of water and without segregation of the aggregates. The chute must be flushed out and properly cleaned before and after each working period. All waste from flushing shall be discharged outside the formwork.

In beams, each portion of a successive layer shall be placed as soon as the concrete below has been properly worked around rods and against formwork. Concreting shall be carried forward in irregular steps, that is to say, one layer shall not be completed over the whole section before the succeeding layer is commenced. Concreting of slabs and beams shall, as far as possible, be carried forward in one operation. When concreting has to be interrupted the concrete shall be left with a level, rough top surface with ends vertical. The concrete shall not be merely sloped down.

On resuming concreting, the old surface shall be roughened and all laitance thoroughly and carefully removed before any new concrete is deposited. This must be carried out by brushing the surface of the concrete while it is still green. Great care must be taken to avoid any weakness at the junction of old and new concrete, and the old surface shall be coated with a thin layer of cement and sand mortar, in the same proportions as that of the adjoining concrete.

While the concrete is setting it shall not be disturbed or shaken by traffic, either on the concrete itself or upon adjoining formwork.

No holes in concrete elements shall be patched or filled in without inspection, instruction and approval of the Engineer.

No concreting shall be carried out when the air temperature is below 4 °C when it is rising and 8 °C when it is falling.

Before concreting is commenced the Contractor shall give the Representative/Agent 24 hours notice of his intention to do so. On sites further than 200 km from the Representative/Agent, 48 hours notice must be given.

Concrete surface beds, excluding heavy industrial floors etc. shall be Class C concrete and shall be laid in suitable size panels not exceeding 20 m² in area and with the length of any panel not exceeding 4,5 m.

Where concrete beams are supported on concrete columns, the columns are to be concreted up to the underside of such concrete beams and then concreted up to the top of the beams, integral with the beams.

NB: Any finish applied to the surface of concrete floors, is to be understood as being additional to the thickness of the concrete described or shown on the drawings.

3.15 CURING AND PROTECTION OF CONCRETE

All concrete shall be protected from contamination, erosion by rain and flowing water, frost, mechanical damage, and vibration and movement that could disrupt the setting or hardening of the concrete and interfere with its bond to the reinforcement.

As soon as it is practicable (including the period before the formwork is removed), all concrete shall be protected from moisture loss for the period necessary for hydration of the cement and hardening of the concrete by one or more of the following methods:

- a) ponding the exposed surfaces with water, except where the temperature is below 5 °C;
- b) covering the concrete with sand, or mats made of a moisture-retaining material, and keeping the covering continuously wet;
- c) continuously spraying the exposed surfaces with water;
- d) covering the concrete with waterproof or plastics sheeting firmly anchored at the edges;
or
- e) the use of a suitable curing compound applied in accordance with the manufacturer's instructions.

NOTE Some curing compounds or finishes, such as toppings, plasters or paints applied to the hardened concrete, inhibit bonding. The compound used should therefore be suitable for the intended finish.

Whichever method of curing is adopted, its application shall not cause permanent staining, contamination or marring of the surface of the concrete. The water used shall comply with the requirements of 3.5.

Curing shall continue for at least the appropriate period given in the Table "Minimum curing periods" or until such time that the concrete in excavations is back filled.

Table — Minimum curing periods

1	2	3
Strength class of cement	Minimum curing period (d)	
	Ambient temperature	
	15 °C and higher	5 °C and lower
42,5 R or higher	3	6
CEM I and CEM II A-S, A-M, A-V or W	7	14
CEM II B-S, B, V or W or CEM III	10	20
NOTE When the ambient temperature is between 5 °C and 15 °C, the curing period shall be determined by interpolation between the given periods.		

3.16 DESCRIPTIONS (PRICES) OF CONCRETE

Descriptions (prices) of concrete work shall be deemed to include the design of concrete mixes and all testing of concrete and materials other than compressive strength testing of concrete samples from concrete being placed in the works (the Contractor shall only be entitled to payment for those samples and compressive strength tests called for by the Employer's Agent Representative and which pass the test requirements), handling and depositing (by hoisting or lowering) concrete in the forms, working and packing concrete around reinforcement, all "construction joints" other than "designated joints" as defined in SABS Specifications 1200G

which are given separately, shaping tops of concrete components as required and striking off and curing. (Treatment of finished faces of concrete other than striking off and curing are given in separate items.)

Descriptions (prices) of concrete in surface beds cast in panels shall be deemed to include formwork, fillets and the like in forming the panels.

3.17 BUILDING ON CONCRETE FOOTINGS AND BEAMS

No brickwork, stone walling or other structure shall be built on concrete footings until at least three days after placement of the concrete in the case of mass concrete footings and after seven days in the case of reinforced concrete footings or as may otherwise be directed by the Employer's Agent Representative.

No brickwork, stone walling or other structure shall be built on reinforced concrete beams or similar members until the formwork and all props or supports have been removed.

3.18 CONSTRUCTION JOINTS

Slip joints shall be provided between concrete slabs and beams by levelling up and trowelling smooth the bearing surfaces of brickwork with 3:1 cement mortar and covering the bearings before the concrete is cast, with two layers of one side smooth tempered hardboard, with the smooth sides in contact.

The ends and sides of beams and edges of concrete slabs shall be separated from the brickwork with 10mm thick bitumen impregnated softboard or expanded polyethylene strips placed vertically against the brickwork before the concrete is cast.

Similar slip joints shall be provided between brickwork and concrete lintels cast in situ, but without softboard or expanded polyethylene strips at ends.

Round of all construction joint edges to a radius of 3 mm.

3.19 ISOLATION OR MOVEMENT JOINTS

All movement joints are to be filled in with approved bitumen impregnated softboard or expanded polyethylene strip unless otherwise specified or detailed on drawings. Form similar movement joints where pathways adjoin buildings externally.

3.20 CUTTING, PUNCHING OR HACKING CONCRETE

No reinforced concrete shall be cut or hacked without the sanction of the Employer's Agent Representative.

3.21 FORMING KEY TO CONCRETE FOR PLASTER AND OTHER FINISHES

Where rough formwork has been used, surfaces of concrete to receive plaster and other finishes, shall, immediately after the formwork has been removed, be well wetted and wire brushed whilst the concrete is still green and then slushed over with 2:1 cement grout to form a key for the finish, all to the approval of the Employer's Agent Representative. The slushing is to be allowed to set hard before the finish is applied.

Where smooth formwork is used, surfaces of the concrete to receive plaster and other finishes shall be hacked, on the distinct understanding that hacking of concrete shall be at no extra cost to the Department.

Surfaces of concrete receiving plaster or other finishes shall not be plastered or finished until the Employer's Agent Representative has signified his opinion in writing that the surfaces are suitable to receive plaster or other finishes.

3.22 SLEEVE PIECES, TIES, ETC.

Where it is necessary to leave plugs or holes in beams, slabs or any other reinforced concrete, all such plugs or holes must be situated in positions approved by the Employer's Agent Representative before concreting. Where it is necessary to carry pipes, bolts, wires or any other fittings through reinforced concrete members, approved pipe sleeves must be provided and placed in position before concreting.

Where waste, ventilation, water, heating or other pipes under 100mm diameter pass through concrete slabs and beams, galvanised mild steel sleeve pieces of diameters shown or required shall be cast into such concrete slabs and beams.

Chases shall be formed in edges of slabs or slots shall be formed in the slabs, of sizes required, where two or more pipes pass through together.

All necessary bolts, plugs, brackets, cramps, etc. shall be cast into the concrete as the work proceeds.

Where brickwork abuts against concrete, the brickwork is to be tied to the concrete with galvanised hoop-iron ties 1,6m thick by 32mm wide and approximately 600mm long to every third course of brickwork with one end of each tie cast approximately 150mm deep into the concrete. Where such fixing is impossible, i.e. where steel formwork is used, ties are to be gun-nailed against concrete with steel nails not less than 38mm long.

3.23 BAGGED FINISH TO CONCRETE

Concrete surfaces to receive bagged finish shall be prepared by removing sharp projections and making good defects with 3:1 cement mortar. Finish by rubbing over the whole area with wet rough sacking and cement grout to obtain an even surface.

3.24 FINISHING OF CONCRETE FOR TROWELLING

Direct-finish of concrete by means of delayed trowelling techniques:

- Level concrete surface by means of straight-edge after vibrating.
- Leave surface undisturbed until bleeding has ceased and surface has stiffened so that foot pressure barely indents the surface (2 – 4 hours).
- Remove bleed water and laitance.
- Hand trowel using pressure, or power trowel.
- Steel trowel to produce a smooth finish, or wood float to produce a slip-free surface.
- Do not add water or neat cement.

3.25 POWER FLOATED FINISH

Power floated finish to floors etc. means that surfaces shall be floated mechanically to a smooth and even finish before the concrete has set. Small areas inaccessible to the machine are to be floated by hand. Under no circumstances is cement mortar to be added while floating the concrete.

3.26 “NO-FINES” CONCRETE

“No-fines” concrete, for grading flat concrete roofs and the like falls, shall be in the proportion of 12 parts 19 iron cubical stone to 1 part cement mixed with 20 litres water per bag of cement and be laid to falls of not less than 15mm per linear metre for mastic asphalt and not less than 20mm per linear metre for sheet roof covering. For heavy load applications special mix designs may be required.

a) Fillits against upstands:

Form triangular fillets, size 75 × 75mm, in corners with walls, kerbs, etc. neatly mitred at angles, stopped where necessary and finished smooth ready to receive waterproofing.

b) To raised floors, bases, etc.:

“No-fines” concrete for raised floors, bases, etc. shall be in the proportions specified. Finish smooth with 3:1 sand/cement screed to receive waterproofing.

3.27 FORMWORK

Formwork shall include all shuttering, casing and centring of whatever material required for the laying and forming of concrete floors, slabs, beams, lintels, walls, steps, columns, piers, pilasters and any other concrete work requiring moulds or forms and shall embrace all cleats, battens, fillets, wedges, struts, trestles, braces, props, shores and other requirements of whatever material for keeping all in correct position. All materials used for formwork must be suitable and substantial and all joints must be tight enough to prevent leakage of liquid matrix.

All formwork must be designed by the Contractor and if requested to do so, he must submit fully detailed and dimensioned working drawings to the Employer’s Agent Representative for checking purposes. Acceptance of the proposals shall not relieve the Contractor of his responsibility for the safety and stability thereof nor for any loss or damage arising out of defective design, materials and/or workmanship.

The formwork must be so constructed that its partial removal can be carried out to the satisfaction of the Employer’s Agent Representative and in such stages as are required by the working conditions.

As far as possible, wedges and clamps must be used in preference to nails. All formwork in its various sections for floors, beams, etc. must be so arranged that the whole may be raised or lowered either independently or together with other sections by means of wedges or other approved methods.

Immediately before concreting is begun, the formwork in contact with the concrete must be thoroughly cleaned, wetted and kept damp whilst the concrete is being placed.

Great care must be taken to keep the formwork wedged up to its correct height and this must be checked by taking levels immediately before concreting is commenced and immediately after it has been completed.

All beams shall have a camber of 6 mm to every 3 m of length.

The minimum periods that the formwork to the various parts of the structure is to remain in position after concreting shall be as stated in the following table:

DESCRIPTION	NORMAL CEMENT		RAPID HARDENING CEMENT	
	WEATHER		WEATHER	
	NORMAL	COLD	NORMAL	COLD
Beam sides, walls, unloaded columns	2 days	4 days	1 day	2 days
Slabs with props left under	4 days	7 days	2 days	4 days
Beam soffits with props left under including ribbed slabs	7 days	12 days	3 days	5 days
Removal of slab props	10 days	17 days	5 days	9 days
Removal of beam props	14 days	28 days	7 days	12 days

When determining the stripping time for formwork the weather shall be considered to be "normal" when the temperature is above 18 °C and "cold" when the temperature is between 5° and 10 °C, these being the average daily temperatures of the atmosphere adjacent to the concrete. When the average daily temperature lies between the above values for "normal" and "cold" weather the minimum period for stripping of formwork shall be determined by the Employer's Agent Representative.

Notwithstanding the above minimum periods, formwork may be struck immediately the concrete in the various parts of the structure has attained the crushing strengths required by the Employer's Agent Representative. The crushing strengths must be determined by proper tests, which shall be carried out by the Contractor.

No formwork of any nature whoever shall be struck, either after the elapse of the minimum period stated above or on the attainment of the required crushing strengths of the concrete, without the prior consent of the Employer's Agent Representative. Such consent will not absolve the Contractor of his responsibility for the safety of the structure.

In structures having either in whole or in part, two or more reinforced concrete floors, props shall be provided under the soff its of any beam or slab of any floor which is being used to support the formwork and wet concrete of the floor above, all to the approval of the Employer's Agent Representative. The props shall not be removed until the formwork supporting the concrete of the floor above has been struck.

On no account shall steel formwork be oiled where concrete is to receive plaster.

Formwork is measured to the net surfaces of concrete to be supported, except at intersections of beams with beams, columns, walls, etc. and tops of columns with slabs, beams, etc. where no deductions have been made and descriptions (prices) shall be deemed to include use and waste, except where the formwork is of a permanent nature or is to be left in, fitting together to all required shapes, all cutting, intersections, cambering where required, holes for rods, bolts, pipes and the like, propping, maintaining, keeping damp whilst the concrete is being deposited and removing.

Formwork "left in" and permanent formwork shall be deemed to include leaving in formwork, props, etc.

Descriptions (prices) of formwork to soffits shall be deemed to include propping not exceeding 3,5m high unless otherwise described. Descriptions (prices) of formwork to walls and columns shall be deemed to be not exceeding 3,5m high above bearing level unless otherwise

described. Descriptions (prices) of formwork to soffits of solid slabs shall be deemed to be to slabs not exceeding 250 mm thick unless otherwise described.

3.28 SMOOTH FORMWORK

Smooth formwork shall be any material approved by the Representative/Agent which is to be used to leave concrete surfaces smooth when removed and where no other finish is to be applied.

Descriptions (prices) shall be deemed to include for rubbing off all projections at seams etc. after removal of the formwork, making good any defects with 2:1 cement mortar and leaving a smooth surface with all arises slightly rounded, all to the satisfaction of the Representative/Agent.

3.29 DAMP-PROOF UNDER-SURFACE MEMBRANE

Horizontal and vertical damp-proof course materials shall either be the subject of an Agrément certificate or comply with one or more of the following standards:

- a) SANS 248;
- b) SANS 298;
- c) SANS 952.

The damp-proof under-surface membrane to be used under concrete floors shall be of a polymer film according to SABS Specification 952 type C (green) 0.25mm thick.

The damp-proof under-surface membrane shall be placed over the full floor area before the concrete floor is casted. The membrane shall be cut straight and square or to shape by the use of sharp instruments.

Joints shall have a minimum overlap of 300mm and sealed with pressure sensitive tape.

3.30 REINFORCING RODS

- a) Mild steel:

Mild steel shall comply with the requirements of SABS Specifications 920, Type A or B.

- b) High tensile steel:

High tensile steel shall comply with the requirements of SABS Specification 920, Type C or D.

3.31 CONCRETE REINFORCEMENT

3.31.1 ROD REINFORCEMENT:

Bending and hooking of rods shall be done in accordance with SABS Specification 282. Rods shall be bent cold in an effective bending machine, or properly designed rod-bender using a steady pressure and not by hammering.

Diameters, lengths and positions of rods as shown on the drawings must be strictly adhered to. Joints in rods in beams, stars, etc. will be permitted only where shown on the drawings.

Before being placed in position, the rods shall be thoroughly cleaned of all grease, dirt, bituminous material, scale and loose rust.

All distribution rods shall be straight and shall extend at least 150mm into beams or other support.

Unless otherwise shown on the drawings, all joints in reinforcing rods shall be lapped 40 times the diameter of the rod. The laps shall be securely tied with 1,25mm diameter annealed mild steel binding wire.

Reinforcement for piles, column footings, columns and walls shall be tied at every intersection, or as directed or shown on drawings, with similar binding wire.

Reinforcement in beams shall be tied at alternate intersections in a diamond pattern, unless circumstances demand every intersection.

Great care must be taken to retain the reinforcement in its correct position during the entire period of concreting. Blocks of fine concrete, size approximately 40 × 40mm, or plastic spacers shall be provided on the formwork to soffits of beams to ensure that the rods are retained in position and that the concrete covering to the main reinforcing rods is provided. The blocks shall be of the thickness required and shall be placed under the main reinforcing rods at approximately 600mm centres.

Reinforcement in the top of slabs and the like shall be retained in position by means of cradles (stools), formed of steel reinforcing rod as follows:

R10 for height range 100 – 300mm and maximum width of 300mm.

R12 for height range 300 – 500mm and maximum width of 450mm.

Recommended spacing of supports for horizontal bars in slabs:

No further than 600mm apart (cradles ± 1000 mm c/c in both directions) for bar diameters up to 12mm.

No further than 1000mm apart (cradles ± 1500 mm c/c in both directions) for bar diameters of 16mm and over.

Stools are to be placed on the bottom layer of reinforcement, securely retained in position and with correct concrete cover as specified. Cradles are to be securely wired to the slab reinforcement with binding wire. Beam rods in different layers shall be separated by means of steel spacer bars of suitable diameters and lengths.

Double mats in concrete walls shall be kept in their respective positions by means of suitable steel clips as follows:

Recommended spacing of supports for vertical bars in walls:

1 000mm centres in both directions for bars up to 12mm diameter.

1 500mm centres in both directions for bars of 16mm diameter and over.

Supports can be spaced more closely by the design Engineer, depending upon the circumstances.

All stirrups shall be properly fastened to the rods so as to retain their relative positions during the entire period of concreting.

Welding of main rods will not be permitted unless, approval has been given by the Employer's Agent Representative. Spot welding in lieu of wiring may be used to secure rods and stirrups in position.

The concrete covering the main reinforcement, unless otherwise specified, shall not be less than that stated in the following table:

Position	Amount of Cover
Soffit of slabs	The diameter of the rods, but never less than 15mm (mm)
End of beams	40
Soffit of beams	40
Sides of beams	40
Sides of columns	40
Slab (under ground cable)	40
Concrete walls	40
Walls (exposed to ground cable)	25
Ground beams	40
Foundations	40
Water retaining structures and within 1km from coast	75 50

Incases not included in the above table the cover shall not be less than 25mm.

Depending on the condition of exposure and fire resistance requirements, concrete cover can be varied by the design engineer but in no case shall the concrete cover be less than the diameter of rod to be covered.

The cover shall be measured from the face of the concrete to the outside of main reinforcement nearest the face of the concrete, and shall exclude plaster and similar finishing materials.

Three samples of each diameter of reinforcing rods, each approximately 600mm long, must be taken from each consignment of rods of similar diameter for testing.

If any sample is found unsatisfactory, the whole consignment of rods from which the samples were taken will be rejected.

Top reinforcement in cantilever slabs to be kept in position with a first row of stools or chairs 300mm from the beam or support, and thereafter at a maximum of 40 bar diameters under each bar.

The cover blocks, spacers, bars and stools or chairs are to be placed and/or wired in position by the steel fixer.

3.31.2 WELDED STEEL FABRIC REINFORCEMENT:

All welded steel fabric reinforcement shall comply with the requirements of SABS Specification 1024.

The preferred dimensions are as follows:

1	2	3	4	5	6
Fabric Reference Number	Nominal pitch of wires		Nominal diameter of wires		Nominal mass* kg/m ²
	Longitudinal mm	Cross mm	Longitudinal mm	Cross mm	
617	200	200	10.0	10.0	6.17

500	200	200	9.0	9.0	5.00
395	200	200	8.0	8.0	3.95
311	200	200	7.1	7.1	3.11
245	200	200	6.3	6.3	2.45
193	200	200	5.6	5.6	1.93
100	200	200	4.0	4.0	1.00
772	100	200	10.0	7.1	7.72
655	100	200	9.0	7.1	6.55
517	100	200	8.0	6.3	5.17
433	100	200	7.1	6.3	4.33
341	100	200	6.3	5.6	3.41
289	100	200	5.6	5.6	2.89
278	100	300	6.3	4.0	2.78
226	100	300	5.6	4.0	2.26
133	100	300	4.0	4.0	1.33

*These mass values are based on the wires having mass of 0,00785 kg/mm² per metre of length.

The actual mass of the fabric should not differ from the nominal value by more than 6%.

3.32 DESCRIPTIONS (PRICES)

Descriptions (prices) for all steel reinforcement to concrete shall be deemed to include cutting and waste, bending, hooked ends, binding at lappings and intersections with annealed wire all as above described, hoisting or lowering and maintaining in position whilst the concrete is being deposited and cover blocks and spacers in accordance with the relevant SABS Codes of Practice.

Descriptions (prices) of standard fabric reinforcement as included in Table 1 of SABS Specification 1024 shall be deemed to include 300mm wide laps.

The mass of binding wire is not included in the mass of the reinforcement and the cost thereof shall be deemed to be included in the prices for the reinforcement.

PC 3 MEASUREMENT AND PAYMENT

Item	Unit
PC 3.1 Mass Concrete cast in panels on waterproofing and slabs to be level.....	cubic metre (m ³)

The unit of measurement shall be the cubic metre of mass concrete for strip footings, column footings, surface beds cast in panels on waterproofing and slabs to be level.

The tendered rates shall include full compensation for the design of concrete mixes and all testing of concrete and materials other than compressive strength testing of concrete samples from concrete being placed in the works (the Contractor shall only be entitled to payment for those samples and compressive strength tests called for by the Engineer and which pass the test requirements), handling and depositing (by hoisting or lowering) concrete in the forms, all "construction joints" other than "designated joints" as defined in SABS Specification 1200G which are given separately, shaping tops of components as required and striking off and curing.

Item	Unit
PC 3.2 Mass Concrete cast in panels on waterproofing and slabs at a fall.....	cubic metre (m ³)

The unit of measurement shall be the cubic metre of mass concrete for surface beds cast in panels on waterproofing and slabs all at a fall.

The tendered rates shall include full compensation for the design of concrete mixes and all testing of concrete and materials other than compressive strength testing of concrete samples from concrete being placed in the works (the Contractor shall only be entitled to payment for those samples and compressive strength tests called for by the Engineer and which pass the test requirements), handling and depositing (by hoisting or lowering) concrete in the forms, all "construction joints" other than "designated joints" as defined in SABS Specification 1200G which are given separately, shaping tops of components as required and striking off and curing.

Item	Unit
PC 3.3 Reinforced Concrete	cubic metre (m ³)

The unit of measurement shall be the cubic metre of reinforced concrete cast in panels on waterproofing.

The tendered rates shall include full compensation for the design of concrete mixes and all testing of concrete and materials other than compressive strength testing of concrete samples from concrete being placed in the works (the Contractor shall only be entitled to payment for those samples and compressive strength tests called for by the Engineer and which pass the test requirements), handling and depositing (by hoisting or lowering) concrete in the forms, working and packing concrete around reinforcement, all "construction joints" other than "designated joints" as defined in SABS Specification 1200G which are given separately, shaping tops of components as required and striking off and curing.

Item	Unit
PC 3.4 Concrete test cubes size 150 × 150 × 150mm.....	Number (No)

The unit of measurement shall be the number of concrete test cubes.

The tendered rates shall include full compensation for the design of concrete mixes and all testing of concrete and materials for compressive strength testing of concrete samples from concrete being placed in the works.

Item	Unit
PC 3.5 Rough formwork	Square metre (m ²)

The unit of measurement shall be the square meter of rough formwork to form opening for casting of concrete slab not exceeding 200mm thickness.

The tendered rates shall include full compensation for the labour and material to manufacture, put in place, secure in position and remove after curing of concrete all rough formwork for the casting of concrete slabs.

Item	Unit
PC 3.6 Smooth formwork	Square metre (m ²)

The unit of measurement shall be the square meter of smooth formwork to special areas as indicated on the drawings or as directed by the Engineer.

The tendered rates shall include full compensation for the cost of all parts of formwork in contact with the concrete, and the necessary bearers, struts and other supports, plus the labour and plant necessary to erect and strike such formwork after curing of concrete.

Item	Unit
PC 3.7 Wooden float top of concrete to be level.....	Square metre (m ²)

The unit of measurement shall be the square meter of concrete floors of the buildings to be wooden floated to be level as directed in the drawings or by the Engineer.

The tendered rates shall include full compensation to wooden float top of concrete to be level, hardwearing, smooth surface in accordance with SABS 0100 Code of Practice.

Item	Unit
PC 3.8 Wooden float top of concrete to be at a slope	Square metre (m ²)

The unit of measurement shall be the square meter of concrete slabs of the buildings to be wooden floated to be at a slope as directed in the drawings or by the Engineer.

The tendered rates shall include full compensation to wooden float top of concrete to be at a slope, hardwearing, smooth surface in accordance with SABS 0100 Code of Practice.

Item	Unit
PC 3.9 Steel float top of concrete to be level.....	Square metre (m ²)

The unit of measurement shall be the square meter of concrete floors of the buildings to be steel floated to be level as directed in the drawings or by the Engineer.

The tendered rates shall include full compensation to steel float top of concrete to be level, hardwearing, smooth surface in accordance with SABS 0100 Code of Practice.

Item	Unit
PC 3.10 Steel float top of concrete to be at a slope	Square metre (m ²)

The unit of measurement shall be the square meter of concrete floors of the buildings to be steel floated to be at a slope as directed in the drawings or by the Engineer.

The tendered rates shall include full compensation to steel float top of concrete to be at a slope, hardwearing, smooth surface in accordance with SABS 0100 Code of Practice.

Item	Unit
PC 3.11 Power float top of concrete to level	Square metre (m ²)

The unit of measurement shall be the square meter of concrete floors of the buildings to be power floated to be level as directed in the drawings or by the Engineer.

The tendered rates shall include full compensation to power float top of concrete to be level, hardwearing, smooth surface in accordance with SABS 0100 Code of Practice.

Item	Unit
PC 3.12 Power float top of concrete to a fall	Square metre (m ²)

The unit of measurement shall be the square meter of concrete floors of the buildings to be power floated to a fall as directed in the drawings or by the Engineer.

The tendered rates shall include full compensation to power float top of concrete to a fall, hardwearing, smooth surface in accordance with SABS 0100 Code of Practice.

Item	Unit
PC 3.13 Expansion joints with 10mm bitumen impregnated softboard between vertical concrete or brick surfaces	metre (m)

The unit of measurement shall be the metre of 10mm thick and not exceeding 300mm high bitumen impregnated softboard expansion joints between vertical concrete or brick surfaces as shown on the drawings or directed by the Engineer.

The tendered rates shall include full compensation for the labour and material to manufacture, put in place, and secure in position all expansion joints during the casting of concrete slabs.

Item	Unit
PC 3.14 Expansion joints with 10mm Joint filler – closed cell expanded polyethylene with tear-off strip at the top	metre (m)

The unit of measurement shall be the metre of 10mm thick and not exceeding 300mm high Joint filler – closed cell expanded polyethylene with tear-off strip at the top expansion joints between vertical concrete or brick surfaces as shown on the drawings or directed by the Engineer.

The tendered rates shall include full compensation for the labour and material to manufacture, put in place, and secure in position all expansion joints during the casting of concrete slabs.

Item**Unit**

PC 3.15 Steel reinforcement kilogramme (kg)

The unit of measurement shall be the kilogram of steel bar reinforcement mesh to structural concrete work.

The tendered rates for all steel reinforcement to concrete shall be deemed to include cutting and waste, bending, hooked ends, binding at lappings and intersections with annealed wire all as above described, hoisting or lowering and maintaining in position whilst the concrete is being deposited and cover blocks and spacers in accordance with the relevant SABS Codes of Practice. The rate tendered of standard fabric reinforcement as included in Table 1 of SABS Specification 1024 shall be deemed to include 300 mm wide laps. The mass of binding wire is not included in the mass of the reinforcement and the cost thereof shall be deemed to be included in the prices for the reinforcement.

Item**Unit**

PC 3.16 One layer of waterproof sheeting under surface beds Square metre (m²)

The unit of measurement shall be the square metre of waterproof sheeting sealed at laps with pressure sensitive tape under surface beds.

The tendered rates for all waterproof sheeting shall include full compensation for all labour and materials, placing of waterproof sheeting below surface beds, cutting and sealing at laps with pressure sensitive tape.

4 SECTION 4: MASONRY

Masonry walling (Including brickwork and stone masonry):

Applicable standard: SANS 2001 – Construction Works Part CM1: Masonry Walling.

SANS 2001-CM1 covers requirements for masonry walls, materials, the laying of masonry units in unreinforced and reinforced applications, the building in of door and window frames, holes and chases, the securing of timber roof structures and the fixing of slips.

SCOPE OF MASONRY WORK.

The masonry work shall consist out of the foundation section up to floor level that shall be built with solid burnt clay units in a Stretcher bond where the masonry units to be used shall be locally produced “Clincker Bricks” supplied from Stutt Group in Stutterheim. The building walls shall be built with hollow concrete masonry units in a Stretcher bond, grey of colour and with nominal dimensions.

The foundation floor section of the masonry work shall be face work jointing with recessed joints. The building walls shall be plastered and paint.

All the door and window farms shall be protected by prestressed lintels on top of it as shown in the drawings.

4.1 MATERIALS

4.1.1 LIME

Lime shall be hydrated bedding mortar lime complying with the requirements of SABS Specification 523.

4.1.2 CEMENT

Cement shall be Portland cement complying with the requirements of SABS Specification 471 or PC15 complying with SABS Specification 831.

Samples of cement from any one, or from every consignment, may be required by the Representative/Agent for test purposes. Cement in any consignment from which a sample may have been taken for testing shall not be used until it has been approved. Allowance must be made for possible delay in that tests may take 10 days to carry out.

Bags of cement shall be stacked in a waterproof, solidly constructed shed with a central door and a floor rendered damp-proof with a tarpaulin. The bags of cement shall be closely stacked (but not against walls) in order to reduce air circulation in such a manner that the cement is used in the order in which it was received, i.e. first in first out.

Unless otherwise specified in the tender documents the use of ordinary Portland cement blended with ground granulated blast furnace slag complying with SABS Specification 1491, or ordinary Portland Cement blended with Pulverised Fly Ash complying with SABS Specification 1466 will be allowed in certain instances as an alternative, after acceptance of tender, but only with the approval of and at the sole discretion of **the Department**. If not so specified in the tender documents the Contractor must demonstrate a saving in favour of the Department together with his alternative tender. The saving offered will be adjudicated by the Engineer/Quantity Surveyor for the service and acceptance of the alternative will be in accordance with the reasonableness thereof.

4.1.3 SAND

Sand shall comply with the requirements of SABS Specification 1090, unless specialist advice is obtained. A sample of 25kg must be delivered to the Employer’s Agent Representative for testing purposes.

4.1.4 WATER

The water used shall be fit for drinking.

4.1.5 BURNT CLAY BRICKS

- a) Burnt clay bricks shall comply with the requirements of SABS Specification 227, and shall be equal in all respects to the selected samples with nominal dimensions of 222 x 103 x 76 mm.
- b) Clay bricks for foundations shall be as described in (a) above, but extra hard burnt and with uniformity of colour and texture. The foundation section shall be build with “Clinker Bricks” approved by the Employer’s Agent Representative.
- c) Where bricks with holes are used, the holes in such bricks must only be filled in solid with mortar where specifically specified.
- d) All bricks that do not carry the SABS Mark, must be tested in a Laboratory approved by the Employer’s Agent Representative for its strength before approval.
- e) Masonry units must comply with the minimum required compressive strengths as set out in the table below:

Table 1 — Compressive strength of masonry units

Description	2		3	
	Hollow units		Solid units	
	Compressive strength			
	MPa			
	Average ^a	Individual I	Average ^a	Individual I
Single-storey construction:				
on-site manufacture ^b	3,0	2,4	4,0	3,2
off-site manufacture	3,0	2,4	5,0	4,0
Double-storey construction	7,0	5,6	10,0	8,0
Cladding and internal walls in concrete-framed housing units	3,0	2,4	5,0	4,0
^a The average compressive strength is based on a minimum of five samples based on the gross surface area. ^b On-site manufacture is where units do not require to be transported more than 25 m to the place where they will be built into walls.				

4.1.6 FIREBRICKS

Firebricks shall be of well burnt refractory fireclay, resistant to spalling and cracking and of same size as ordinary bricks.

4.1.7 CONCRETE MASONRY UNITS

- a) Concrete masonry units shall comply with the requirements of SANS Specification 1215 and shall be hollow on the inside, gray of colour and with nominal dimensions of 390 × 140 × 190mm or 390 × 190 × 190mm.

4.2 WORKS MORTAR TESTS

4.2.1 SAMPLING

The frequency of sampling will be decided by the Employer's Agent Representative. Sufficient mortar shall be taken from each of the points of laying to prepare a composite sample to make a set of three mortar cubes.

4.2.2 MOULDING

Cube moulds with a nominal size of 100mm, that comply with SABS STM 863 must be used.

Fill each mould with mortar in three equal layers and compact each layer by means of a tamper.

The tamper must be made of hard wood with a flat tamping surface with nominal dimensions of 50 × 25mm and shaped to provide a round stem of approximately 25mm diameter and long enough to afford sufficient hard grip. Immerse the tamper in water for 15 minutes before each use.

Each layer of mortar must be compacted by means of 8 evenly spaced pressing strokes of the tamper. After the final layer has been tamped, the excess mortar must be struck off level with the top edges of the moulds.

4.2.3 CURING

Cover the test cubes (in their moulds) with an impervious sheet followed by wet marring sacks or similar material, and store them in a place free from vibration, excessive draughts and direct sunlight.

After 24 hours mark each cube so that it can be identified. After 48 hours the cubes must be removed from their moulds and placed into water in a curing tank at 22° - 25° C for a minimum period of 7 days before they are transferred to the testing laboratory. Ensure that loss of moisture is prevented during transportation and that they are well protected against damage.

4.2.4 TESTING OF CUBES

The testing of cubes will be done by a Laboratory selected by the Contractor and approved by the Employer's Agent Representative in accordance with SABS STM 863.

4.3 CEMENT MORTAR

Cement mortar shall be composed of 6 parts (by volume) of sand and 1 part (by volume) of cement. The material shall be mixed dry until of uniform colour and then water added and the mixture turned over until the ingredients are thoroughly incorporated. Cement mortar shall be

produced in such quantities as can be used before commencing to set as no cement mortar that has once commenced to set shall be used in any way. Care shall be taken in mixing cement mortar to remove from the mixing machine or platform any old mortar that has already set as such mortar may not be incorporated into any new batch.

4.4 **COMPO MORTAR**

Compo mortar shall be composed of 6 parts (by volume) of sand – depending on the quality of the sand available, 1 part of lime and 1 part of cement (by volume). The lime and sand shall be mixed dry, then wet, before the cement is added, approximately half an hour before using and the adding of the necessary additional water as required.

Compo mortar shall be produced in such quantities as can be used before commencing to set, as no compo mortar that has once commenced to set shall be used in any way.

In all cases the mortar should achieve the minimum required strength (in MPa) for the classes of mortar as set out in the National Building Regulations.

4.5 **BRICKWORK**

Brickwork, wherever practicable, shall be built in Stretcher bond. No false headers shall be used and none but whole bricks employed, except where legitimately required to form bond.

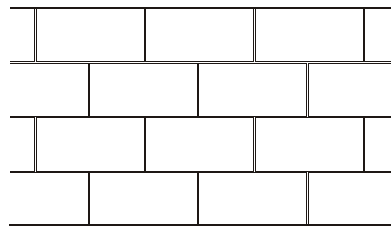

Stretcher Bond

Brickwork shall be built level and plumb with mortar as specified.

The bricks shall be laid on a solid bed of mortar and all joints thoroughly grouted up solid throughout the whole width of each course.

The brickwork shall be carried up in a uniform manner, no one portion being raised more than 1,2m above another at any one time.

Clay bricks shall be well saturated with water, in the stack or dump, approximately 2 hours before being used. The tops of walls left unfinished shall be wetted before work recommences.

NB: Cement or concrete bricks shall not be wetted.

All rough and fair cutting, cutting of splays, skewbacks, chamfers, etc. shall be properly formed.

Form or leave all necessary openings for pipes etc. and make good after pipes etc. are fixed in position.

4.6 BRICKWORK IN CEMENT MORTAR

- a) All brickwork below damp course level, all isolated piers three bricks wide and under, half brick walls and chimney stacks above ceiling level, shall be built in cement mortar as described in 3 above.
- b) Brick arches and brick lintels shall be built in cement mortar as described in 3 above in the proportion of 3:1.

4.7 MORTAR JOINTS

Mortar joints to brickwork generally shall be 10mm in thickness with level bedding joints and vertical perpend.

The joints in brickwork receiving plaster, tiling or similar finishes shall be raked out whilst the mortar is soft to form key for the plaster or mortar backing. The depth of the raking out will depend on the condition of the bricks; the rougher the bricks on face the shallower the raking out and the smoother the bricks the deeper the raking out.

The joints in brickwork shall be flushed off where walls are to be bagged, in readiness for the bagging.

4.8 GROUT IN JOINTS IN BRICK FOUNDATION WALLS

All joints in brick foundation walls shall be grouted in solid with 3:1 liquid cement mortar to obviate any crevices for ant (termite) tracks.

4.9 BRICKWORK IN THICKNESSES

Walls built in two or three half brick thicknesses shall only be built where bonded brickwork proves impractical or where required due to prescribed bond of faced brickwork, all tied together with metal ties in accordance with SABS Specification 28, of the Butterfly or Modified PWD Types, of sufficient length to allow not less than 75mm of each end to be built into the brickwork. Ties shall be evenly spaced at not more than 1m apart to every third course and staggered.

4.10 BRICKWORK IN LININGS

Brickwork linings to concrete shall be tied thereto with 4mm diameter galvanised crimped wire ties bent at ends and of necessary length to allow 75mm to be cast into concrete and 75mm of the other end to be built into brickwork and evenly spaced at no more than 1m apart to every third course and staggered.

4.11 HALF BRICK THICK WALLS

Half brick thick walls shall be built in cementmortar as described in 4.3 above and reinforced with 75mm wide brick reinforcement as described in 4.14 below, 1 row to every 8 course in height, and built 100mm into main connecting walls. The reinforcement shall be lapped 150mm at end joints, where these are necessary, and 75mm at angles.

4.12 CAVITY WALLS

Cavity walls shall be built with two half brick thicknesses of brickwork in stretcher bond with 50mm cavity between, and the two thicknesses tied together with 200mm long metal wall ties evenly spaced at not less than the rate of 9 ties per m² of face area. The ties shall comply with the requirements of SABS Specification 28 and be of the Butterfly or Modified PWD Type only.

The brickwork shall be built level and plumb with mortar as specified.

The cavities shall be carried up from 1 course of brickwork below damp course level up to two courses below roof plate level. The brickwork above cavities shall be built solid and where 270mm thick shall be cut and well bonded where possible.

The cavities shall be kept free of all rubbish, mortar droppings and projecting mortar.

The top of walls shall be covered with planks or sacking during wet weather to prevent rain from entering the cavities.

From weepholes in outer skin of external cavity walls by leaving the perpendicular joints open, one every 1m apart in the second brick course below the damp-proof course.

The cavities shall not be ventilated.

At door, window and other openings the cavities shall be stopped 110mm back from jambs of openings with the inner thickness of brickwork returned and stopped against the outer thickness and not bonded to same. A 100mm wide strip of damp proof sheeting as described for damp courses in PPS CM 29 below shall be built into the joint formed between the return and the outer thickness. Each damp-proof strip shall be lapped at least 50mm on to the damp-proof course between the two wall thicknesses of sills and between the two wall thicknesses of lintels.

Sills of windows shall be divided into external and internal thicknesses with strips of damp-proof sheeting as above, built in line with the damp-proof sheeting in jambs and extending 100mm beyond the jambs of openings.

The lintels shall be provided with damp-proof sheeting as described under lintels.

Cavities shall be stopped 1 course below and 1 course above and 110mm from sides of openings for air bricks and the like.

4.13 BEAM FILLINGS

Beam filling shall be half brick thick, built up in mortar as used in the walls below, cut in between roof timbers and carried hard up to underside of roof covering and flushed up with mortar.

4.14 REINFORCED BRICK LINTELS

Reinforced brick lintels shall be built with sound machine made bricks in 3:1 cement mortar with all vertical and horizontal joints filled with solid mortar throughout the required number of courses and to a distance of at least 330mm on either side of the clear opening.

The number of courses in lintels over the various size openings shall be as specified in the table hereunder and reinforcing steel wires or rods shall be built into the first horizontal joint over the bottom course to the number specified in the following table:

Clear or daylight span	Number of Courses	Reinforcement
Not exceeding 1m	4	One row of 75mm wide brick reinforcement as described below, for each half brick width of soffit
Over 1m to 1,5m	6	Ditto
Over 1,5m to 2,5m	7	Three 6,3mm diameter mild steel rods for each half brick width of soffit.
Over 2,5m to 3,0m	8	Ditto

Brick reinforcement shall be of hard drawn mild steel comprising two 2,8mm diameter main wires spaced 75mm apart and 2,5mm diameter cross wires spaced at not exceeding 300mm apart, welded to main wires.

The reinforcing wires and rods shall be of length at least equal to the width of the clear opening plus 300mm at each end. The reinforcement shall be evenly spaced in the brick joints with the outer wires or rods having at least 20mm cover from face of brickwork.

Brick lintels in 270mm thick cavity walls shall be built with inner face of outer thickness, for a depth of three courses above soffit, covered with sheeting as for dampcourse, the full length of lintels, and space between the two thicknesses for the depth of the sheeting filled in solid with 20 MPa concrete. Where cavities continue above lintels, the sheeting shall be taken up and turned on top of first course of brickwork to inner thickness of wall above the concrete filling in lintels. The sheeting is not required in lintels protected from the weather.

The lintels, except where built over pressed steel door frames and the like, shall be supported on temporary turning pieces of suitable and substantial construction left in position for at least 14 days for long spans (1 to 3m).

4.15 PRESTRESSED LINTELS

Prestressed lintels shall be vibrated concrete reinforced with stressed high tensile steel wires, or of burnt clay blocks with similar reinforcing wires embedded in groves in the blocks in 1:1½ cement/sand mortar, or of other approved form of construction.

Concrete in lintels shall attain a crushing strength of at least 34 MPa at 28 days for ordinary and at 7 days for rapid hardening cement.

The reinforcing wires shall be of ductile high tensile steel wire not less than 4mm diameter and of tensile strength of at least 1 350 MPa and shall be stressed to not less than 850 MPa.

The lintels may be in single width to the thickness of wall or may be in two widths, placed side by side, and shall have a depth of not less than 60mm. top surface of lintels shall be suitably roughened, indented or shaped to give a good bond between the lintels and the mortar for the first course of brickwork above.

Lintels shall have bearings of not less than 225mm on walls at each end.

The number of reinforcing wires in lintels for the various wall thicknesses and spans shall be not less than specified in the table hereunder, and brick courses over lintels of the number indicated in the table and for the full length of lintels shall be built in 3:1 cement mortar with all joints filled solid with mortar, viz:

Nominal wall thickness (mm)	Clear daylight span	Number of wires (in total number of lintels used)	Number of brick courses over lintel
90 – 110	Not exceeding 1,8m	2	3
90 – 110	Over 1,8m to 3m	3	4
180 – 230	Not exceeding 1,8m	6	4
180 – 230	Over 1,8m to 3m	6	4
270	Not exceeding 1,8m	7	4
270	Over 1,8m to 3m	7	5
340	As described for 1 of 230mm plus 1 of 110mm, or 3 of 110mm		

Lintels in 270mm thick cavity walls shall be in two widths with joint between the two arranged directly over the window or frame below, and the brickwork above shall be built in two half brick thickness with inner face of the outer thickness covered with sheeting as for damp-course, the full length and depth of lintels, and taken down between the two widths of prestressed lintels. The cavity to height of lintel courses shall be filled with 20 MPa concrete, and where cavities continue above the lintel courses the sheeting shall be taken up and turned on top of first course of brickwork to inner thickness of wall above the lintel course. The sheeting is not required in lintels protected from weather.

4.16 BAGGED FINISH TO BRICKWORK

Bagging to walls is to be carried out after the mortar in joints has set. The wall surfaces shall be rubbed over with wet rough sacking until all joints and crevices are filled up and an even surface is obtained. Cement grout shall be added if necessary to fill the joints and crevices.

4.17 RAKING OUT FOR AND POINTING FLASHINGS

Brick joints shall be raked out where required for fixing cover flashings and flashings, which shall be pointed in 3:1 cement mortar.

4.18 MASTIC POINTINGS

Where steel door and window frames are specified to be pointed with mastic compound they shall be pointed all round externally with an approved waterproofing compound of such composition that it will not stain surrounding surfaces and that it will adhere tenaciously, remain plastic without sagging or running, be capable of accommodating any normal movement of the joint sealed, and will receive paint without "bleeding". The pointing material shall be forced into the joints, which shall have been previously prepared to receive same, by means of a pressure gun or by other suitable method, all in accordance with the Manufacturer's instructions.

4.19 BUILDING IN

Ends of timbers, holdfasts, cramps, gratings, air bricks, dowels, etc. shall be built-in cement mortar.

Door and window frames, lift door frames and the like shall be set up in position for building in and securely strutted to prevent distortion whilst the brickwork, lintels, etc are being built.

Pressed steel door frames shall be grouted in solid at back with cement mortar as the work proceeds.

Wood slips, fixing bricks, hoop iron roof ties, etc. shall be built in as the work proceeds.

4.20 SECURING ROOFS

Roof trusses shall be fixed at each support to walls with ties of 1,6mm thick galvanised hoop iron, 32mm wide, built 750mm deep into brick work or embedded 300mm deep into concrete or wrapped around bottom layer of reinforcing in a reinforced concrete beam and wrapped over truss and fixed with four galvanised nails, 40mm long.

4.21 CRAMPS TO WOOD FARMES

Wood frames to doors, windows, etc. shall be set up in position for building in as described and built in as the work proceeds with cramps to jambs of 1,6mm thick galvanised hoop iron, 32mm wide, with ends turned 50mm up against stiles of frames and each twice screwed to frame and built 450mm into wall with end turned up into brickwork joint. Cramps shall be built in approximately 0,3m up from bottom and approximately 0,3m down from head of frames and intermediately at not exceeding 0,85m apart. No frame shall have less than two cramps to each jamb irrespective of height.

Cramps to frames in 270mm thick cavity walls shall be cranked as necessary and built into inner and outer thickness of walls alternatively.

4.22 BEDDING AND POINTING

All door, window and similar frames shall be bedded and pointed in 3:1 cement mortar. All wall and floor plates shall be set true and level and bedded in 6:1 cement mortar.

4.23 FACED BRICKWORK

Faced brickwork shall be built fair and pointed with a keyed or recessed joint as specified.

Keyed joint shall mean that the joints are to be pointed with a round jointing tool, well pressed into the joints as the work proceeds.

Recessed joint shall mean that the joints are to be square recessed to a depth of approximately 6mm formed with a rectangular jointing tool well pressed into the joints as the work proceeds.

Facing bricks shall be sorted by the brick manufacturer at his yard or by the Contractor on the site to ensure that proper mixing of the bricks within the colour range of each type of facing being used is obtained. Sudden changes in the general colour of face work in any 1 type of facing brick will not be acceptable.

4.24 FIBRE CEMENT SILLS

Sills shall where in any way possible be in single lengths, cut between reveals, fitted with fixing lugs and solidly bedded in 3:1 cement mortar with a slight projection beyond the finished wall face below.

Internal sills shall be level. External sills shall be set sloping on cut brickwork.

4.25 INSTALLATION OF ELECTRICAL SERVICE

The installation of electrical service, where such service is being provided, will be carried out by a fully qualified electrical sub-contractor, but the Contractor must embed in the concrete, as the work proceeds, all conduits, boxes, etc., which will be fixed in position by the electrician, and must cut all necessary chases and holes in walls for conduits and form recesses in walls for distribution boards, all in the positions directed. Alternatively, distribution boards may be built into walls as the work proceeds, providing prior approval is obtained from the Employer's Agent Representative.

The Contractor shall afford every facility and shall render reasonable assistance to the electricians in carrying out their work and shall make good where necessary, in all trades, after installation has been completed.

Chases, holes and recesses required in walls shall be cut and formed as follows:

- Vertical chase for single conduit;
- Vertical chase for two conduits;
- Vertical chase 150mm wide and 110mm deep for conduits;
- Vertical chase 250mm wide and 110mm deep for conduits;
- Vertical chase 380mm wide and 110mm deep for conduits;
- Vertical chase 560mm wide and 110mm deep for conduits;
- Horizontal chase for single conduit.
- Holes 25mm diameter, or knocking out bricks and filling space and making good after a pipe has been fixed through a wall.

Recesses for distribution boards

Width mm	Height mm	Depth mm
330	330	110
455	330	110
635	330	110
610	660	110
610	910	110

4.26 CABLE SLEEVES

Provide under buildings where required 100mm diameter plastic pipes as sleeves for electric cable taken up to floor level in cable duct or switch cupboard with easy bends. The pipes shall be as specified for drainage including laying and jointing.

4.27 SPECIAL WORKS

The work in connection with the installation of heating, air conditioning, ventilation, refrigeration, automatic sprinklers, telephone systems will be carried out under separate contracts. In order to facilitate this work the Contractor must act on the instructions of the Employer's Agent Representative with regard to special preparations for fittings, leaving holes and openings, forming chases in floors, walls, etc. for pipes, cables, etc and for building in pipes, sleeves, pipe clips, bolts, etc. as required or directed.

All cutting of holes through finished floors, walls, etc. after the concrete has set, must be avoided as far as possible. The Contractor must give ample notice to the Employer's Agent Representative who will ascertain the exact positions where pipe sleeves, pipes, pipe clips, etc. are to be fixed.

4.28 PROTECT AND CLEAN DOWN FACE BRICKWORK

All face brickwork, tiling, etc. liable to damage shall be covered up and protected during the progress of the remaining work and any damage done shall be made good to the satisfaction of the Employer's Agent Representative.

All face brickwork, tiling, etc. shall be cleaned down as the work proceeds and shall be covered up with paper, pasted on, or by other approved means where necessary to prevent soiling of the surfaces during the progress of the remaining work. At completion of the works the coverings shall be removed and the surfaces cleaned down to the satisfaction of the Employer's Agent Representative.

Any detergent or other materials used in the cleaning down of face brickwork etc. shall be of such a nature that will not harm adjoining paint and other finishings in any way.

All pavings shall be thoroughly cleaned of after laying to remove all traces of mortar and other substances, covered up and protected from damage during the progress of the works and again cleaned off at completion.

4.29 DAMP-PROOF COURSE

The horizontal and vertical damp-proof course shall be of black polyethylene sheeting complying with SABS Specification 952 Type B having embossed surfaces, 0,38mm thick (375 microns) and manufactured in widths of less than 1 000mm.

The damp-proof course shall be the full thickness of walls above foundations, plus the width of floor plates where these occur, and shall be laid without longitudinal joints. At end joints, angles and intermediate junctions the sheeting shall be lapped for 150mm.

Where so required all laps in the damp-proof course shall be sealed over the whole area of laps as recommended by the Manufacturere. Care shall be taken not to tear or otherwise damage the sheeting.

Similar damp-proof course, 120mm wide × 250mm long, shall be laid on sleeper piers under the floor bearers.

Similar damp-proof course, but in unbroken lengths, shall be laid behind all window sills, sealed with an approved bituminous solution to the back of the sills and taken down within the thickness of the wall and under the first full course of external brickwork.

NB: No damp-proof course shall be laid directly below the mortar or other bedding material under window sills.

4.30 DAMP-PROOF MEMBRANE

The damp-proof membrane under surface beds shall, unless otherwise specified, be of green polyethylene sheeting complying with SABS Specification 952 Type C – plain surface – 0,25mm thick (250 microns) and manufactured in widths of 1 000mm and greater, all laid in the widest practical widths to minimise joints, turned up and dressed to load bearing walls and, if applicable lapped with the damp-proof course in the walls. All joints shall be sealed with pressure sensitive tape applied over the leading edge of the joint.

NB: All cutting of plastic membranes shall be carried out using sharp instruments.

PC 4 MEASUREMENT AND PAYMENT

Item **Unit**

PC 4.1 Brickwork: Square metre (m²)

The unit of measurement shall be the square metre of brickwork in cement mortar comprising of 6 parts of sand and 1 part of cement for all foundation walls of the building.

The tendered rates for all brickwork shall include full compensation for all labour and materials, the placing of bricks, the cutting of bricks, reinforcing of brick walls, cleaning down and removal of mortar droppings, protection of work against damage and bracing during construction.

Item **Unit**

PC 4.2 Extra over ordinary brickwork for facing in Stretcher bond and pointing in resessed joints as described Square metre (m²)

The unit of measurement shall be the square metre of ordinary brickwork in cement mortar build to Stretcher bond and pointed to resessed joints for all foundation walls of the building.

The tendered rates for all facings externally of the clincker brickwork shall include full compensation for all labour to the Clincker face bricks to ensure them having a high degree of size, shape and colour uniformity pointed with flush horizontal and vertical resessed joints.

Item **Unit**

PC 4.3 Blockwork in cement mortar for walls..... square metre (m²)

The unit of measurement shall be the square meter of blockwork in cement mortar comprising of 6 parts sand and 1 part cement for all the walls of the buildings build to Stretcher bond.

The tendered rates for all blockwork shall include full compensation for all labour and materials, the placing of blocks, the cutting of blocks, reinforcing of block walls, cleaning down and removal of mortar droppings, protection of work against damage and bracing during construction.

Item **Unit**

PC 4.4 Brick-on-egde sill 220mm wide set sloping and slightly projecting (m)

The unit of measurement shall be the metre of brick-on-edge sills of approved face bricks pointed with recessed joints on all exposed faces.

The tendered rates for all brick-on-edge sills shall include full compensation for all labour and materials, the placing of bricks, the cutting of bricks, placing of damp-proof to sills, cleaning down and removal of mortar droppings, protection of work against damage and bracing during construction.

Item **Unit**

PC 4.5 Reinforcement to brickwork and blockwork metre (m)

The unit of measurement shall be the metre of high tensile steel brick reinforcement to brickwork and blockwork.

The tendered rates for all reinforcement shall include full compensation for all labour and materials, placing of reinforcement well laped at all angles and passings and build into brick and block walls.

Item **Unit**

PC 4.6 Prestressed fabricated lintels metre (m)

The unit of measurement shall be the metre of prestressed concrete lintels in lengths not exceeding 3m.

The tendered rates for all prestressed concrete lintels shall include full compensation for all labour and materials, placing of prestressed concrete lintels well fixed at all ends into brick and block walls.

Item **Unit**

PC 4.7 One layer of 375-micron damp proof course in walls Square metre (m²)

The unit of measurement shall be the square metre of 375 micron embossed damp proof course in walls.

The tendered rates for all 375-micron damp proof course shall include full compensation for all labour and materials, placing of damp proof course below brick and block walls as well as below window sills.

5 SECTION 5: CEMENT PLASTER

All cement plasterwork shall comply with the requirements of SANS 2001-EM1 Specification for Construction Works – Cement Plaster.

This part of SANS 2001 covers the application, to masonry and concrete surfaces, of cement plaster which,

- a) in its fresh state, is workable, cohesive and has water-retention properties; and
- b) in its hardened state, is durable, has sufficient strength to hold paint, withstand local impact and abrasions, is free of unsightly cracking and adheres to substrate.

5.1 CEMENT

Cement, unless otherwise specified, shall comply with the requirements of SANS 50197-1 or SANS 50413-1.

NOTE1 Bags should be clearly marked with the strength grade, cement type and a certification mark, and should provide guidance for plaster as given in table 1.

NOTE 2 Caution should be exercised when class 42,5 R and 52,5 N cements are used in plaster, as the resultant plaster might be brittle.

Bags of cement shall be stacked in a waterproof, solidly constructed shed with a central door and a floor rendered damp-proof with a tarpaulin. The bags of cement shall be closely stacked (but not against walls) in order to reduce air circulation in such a manner that the cement is used in the order in which it was received, i.e. first in first out.

5.2 SAND

Sands shall, unless otherwise specified,

- a) comply with the requirements of SANS 1090 for plaster sands, or
- b) not contain any organic material (material produced by animal or plant activities) and be such that when 2,5kg of cement is mixed with 12,5kg sand, no more than 2,7 L of water is required to bring the mix to a plastering consistency

5.3 WATER

Water used shall be fit for drinking.

5.4 PLASTER MIXES

The mix proportions of the cement plaster shall be in accordance with table 1.

Table 1 – Mix proportions for common cements

1	2	3	4
Type	Common cement kg	Loose sand	
		L Max.	Number of standard wheelbarrows
External plaster	50	150	2,5
Internal plaster	50	200	3

A standard wheelbarrow for concrete that complies with SANS 795 has a capacity of between 60 L and 70 L

No admixtures shall be added to the mixes to improve workability or to improve the properties of the finished plaster.

The workability of the plaster can be assessed and improved in the following manner:

- a) Place a small quantity of the mix (at plastering consistency) on a non-absorbent surface and form a flattened heap about 100mm high and 200mm in diameter. Place a plasterer's trowel on top of the heap and push the trowel downwards. A mix with adequate workability is one which permits the mix to squeeze out from under the trowel, and allows the trowel to be pushed to within a few millimetres of the underlying surface. An unworkable mix will "lock up" once the trowel has moved a few millimetres and prevent further downward movement of the trowel.
- b) The workability, cohesiveness and water retention of a mix may be improved by adding hydrated building lime to the mix.

5.5 MIXING OF PLASTER

Sand shall be securely measured by means of calibrated buckets or wheelbarrows. Cement shall only be measured by mass.

Cement plaster shall be mixed on a surface free of contaminants. Before the addition of any water, the dry ingredients shall be mixed until a uniform colour is achieved, thus ensuring a uniform distribution of the ingredients. Material that is not applied to walls within 2 h of mixing, shall be discarded.

5.6 SURFACE PREPARATION

The surface to which plaster is applied shall be free from oil, dirt and other substances that might affect the bond with the plaster.

Before the application of plaster, the substrate surface shall be tested for suction by spraying a small section of the wall with a fine spray. Should droplets of water run down the surface, a proprietary bonding agent, applied to the substrate in accordance with the manufacturer's instructions or a spatterdash layer as described below shall be used to provide a key for the plaster. Should the substrate exhibit excessive suction, the whole wall shall be dampened and allowed to surface dry before the plaster is applied.

Substrates shall be checked for surface roughness. If smooth, the surface shall be either roughened or covered with a spatterdash layer that comprises of one part cement to one and a half parts of coarse sand, with enough water to provide a sluggish pourable consistency. The application of the spatterdash shall result in the entire substrate having a rough texture with nodules approximately 5mm high and no further than 50mm apart. The spatterdash shall be kept moist for at least 3 days after being applied to a substrate.

The substrate surface shall be checked for planeness before the application of the plaster. Where the substrate surface deviates by more than 10mm from a straight edge, the high spots shall either be removed by means of hacking or cutting, or the low areas shall be filled by the application of an undercoat plaster so that the plaster thickness can be achieved.

5.7 PLASTERING

Before any plastering commences, all chases shall be completed and all electrical and plumbing conduits, boxes, etc. shall be fixed in position.

Plaster coats shall be applied in such a manner that the thickness achieved throughout the plastered areas are within the following limits, provided, however, that the total thickness is not in excess of 22mm on masonry substrates, and 16mm on concrete substrates:

a) Multicoat plaster:

First undercoat:	8mm to 16mm
Second undercoat (if any)	6mm to 10mm
Finishing coat:	5mm to 8mm

b) Single-coat plaster: 10mm to 16mm

Plaster shall not be applied to walls when extreme moisture and temperature conditions might affect the finished work (Plaster is particularly vulnerable to drying winds).

Plastering shall be executed in one operation. Joints in plasterwork may only be provided at intersections between surfaces or at changes in direction. Plaster shall be firmly trowelled onto walls.

Plaster shall be returned into reveals and soffits of openings and all corners shall be true and straight with salient corners slightly rounded.

Plaster shall not be allowed to dry out too quickly and shall be damped by means of a light spray for a period of not less than 3 days after being applied to the substrate. Successive coats of plaster shall only be applied after the substrate coat has hardened sufficiently to bear a new layer or to enable a new layer to adhere to it and limit drying shrinkage crazing and cracking.

Plaster shall be discontinuous across the line of the damp-proof course, a butt joint, a movement joint or at the interface between masonry and concrete elements. The plaster shall be cut back to the substrate with a steel trowel to form a V-joint. The V-joint formed at the intersection of masonry walls with precast concrete flooring soffits shall be filled with an appropriate, elasto-plastomeric sealant.

Joints formed in the walling shall be carried through the plaster. Such joints shall be formed by cutting the plaster approximately 30 minutes after it has been applied. The material within the joints shall be removed to permit the sealing of the joints with an appropriate silicone, polyurethane or polysulphide sealant.

PC 5 MEASUREMENT AND PAYMENT

Item	Unit
-------------	-------------

PC 5.1 15mm thick cement plaster on internal walls	Square metre (m ²)
--	--------------------------------

The unit of measurement shall be the square metre of 15mm thick cement plaster (3 : 1) finished with a steel trowel on internal walls.

The tendered rates shall include full compensation for the design of plaster mixes, materials for the cement plaster, labour for handling (by hoisting or lowering) cement plaster, working and plastering of walls including "construction joints" and curing of plaster.

6 SECTION 6: STRUCTURAL STEELWORK

6.1 STEEL

All structural steelwork shall comply with the requirements of SANS 2001- Part CS1: Specification for Construction Works – Structural steelwork

This part of SANS 2001 covers structural steelwork for buildings and other structures, excluding bridges, offshore structures, mobile equipment (stackers, reclaimers, draglines, cranes, etc.), mine shaft steelwork (buntons and guides) and mining conveyances.

All structural steelwork shall be of mild steel complying with the requirements of SANS 1431.

The dimensions and permissible deviations of all steel profiles shall comply with the requirements of the standards listed in Table 1.

Table 1 – Standards governing dimensional and permissible deviations

1	2
Profile	Applicable standard
Angles	EN 10056-2
Hollow sections cold-formed	SANS 657-1
Hollow sections hot-formed	EN 10210-2
I, IPE and H sections	EN 10034
Imperial channels	BS 4-1
Metric channels	DIN 1026-1
Plates, flats and bars	ASTM A 6/A 6Mb
Taper flange I-sections	EN 10024

All steel surfaces shall not be more heavily pitted or rusted than rust grade C of ISO 8501-1.

Surface defects in hot-rolled sections, plates and wide flats revealed during surface preparation, and which are not in accordance with the requirements of SANS 1431, shall be rectified to comply with such requirements.

Surface defects in hot-rolled hollow sections revealed during surface preparation and which are not in accordance with the requirements of EN 10210-1, shall be rectified to comply with such requirements.

6.2 STRUCTURAL STEELWORK

All structural steel shall be hot rolled mild steel. For inland areas, cold rolled steel sections may be used for purlins and side cladding rails only.

Construction methods and the design of steelwork shall be in accordance with the provisions contained in the latest edition of the National Building Regulations: SABS 0400.

Notwithstanding the requirements of the foregoing specifications; materials, workmanship, setting out, erection methods, riveting, bolting, welding, etc. shall be of the best quality, all to the satisfaction of the Employer's Agent Representative.

6.2.1 WELDING CONSUMABLES:

Consumables for use in metal arc welding shall comply with the appropriate standards listed in Table 2.

Table 2 – Approved parent metal-filler weld material combinations for steels acceptable for prequalified welding procedure standards.

1	2	3	4	5	6
Parent metal		Process	Filler weld metal		
Minimum yield strength Mpa	Minimum ultimate tensile strength Mpa		Electrode	Minimum yield strength Mpa	Minimum ultimate tensile strength Mpa
300	450	SMAW - (Shielded metal arc welding)	AWS A5.1 E70XX	365	480
		SAW - (Submerged arc welding)	AWS A5.17 F7XX - EXXX	400	480/680
		GMAW - (Gas metal arc welding)	AWS A5.18 ER70S - X	400	480
		FCAW - (Flux-cored arc welding)	AWS A5.20 E7XT - X	400	480
350 or 355	480	SMAW - (Shielded metal arc welding)	AWS A5.1 E7015, E7016 E7018, E7028	400	480
		SAW - (Submerged arc welding)	AWS A5.17 F7XX - EXXX	400	480
		GMAW - (Gas metal arc welding)	AWS A5.18 ER70S - X	400	480
		FCAW - (Flux-cored arc welding)	AWS A5.20 E7XT - X	400	480

6.2.2 STRUCTURAL FASTENERS:

The mechanical properties of bolts, screws and nuts shall be in accordance with the following standards or as stated on the drawings:

- a) Class 4.8, 8.8 and 10.9 bolts and screws: SANS 1700-5-1
- b) Class 4 to 11 nuts: SANS 1700-2-2

Bolts, screws and nuts shall comply with the following standards:

- a) Bolts: SANS 1700-7-1 or SANS 1700-7-3
- b) Screws: SANS 1700-7-4 or SANS 1700-7-5
- c) Nuts: SANS 1700-14-2 or SANS 1700-14-3
- d) Hot-dip galvanized bolts: SANS 1700-14-9 or SANS 1700-14-11

6.2.3 HOLDING-DOWN (HD) BOLTS:

Holding-down bolts shall be fabricated from round bar that complies with the requirements of SANS 1431 grade 300WA.

6.2.4 WASHERS:

Plain washers shall be in accordance with the provisions of SANS 1700-16-2. Through-hardened washers shall be in accordance with the provisions of SANS 1700-16-3.

6.3 DETAILED DESIGN AND DRAWINGS FOR STRUCTURAL STEELWORK

The Contractor is to employ the services of a registered Structural Engineer to execute the necessary geotechnical investigation of the foundation materials and to design a steel portal frame structure of 23m x 9m x 3m, to prepare a complete set of structural design and shop drawings and submit two sets to the Engineer for approval before the fabrication thereof can commence and execute the full construction inspections during the manufacturing and erection of the portal frame structure including the concrete footings, steel structure, and sheet covering of the roof.

All drawings shall be prepared in accordance with the recognized industry standards i.e. "The South African Institute of Steel Construction publication, ***South African structural steelwork detailing manual.***"

Revised drawings shall have a term added to the drawing and a description in the notes stating the changes that have been made and the date they were made. Furthermore, whenever possible, the most recent revisions to design drawings should be individually highlighted where they occur in the drawing.

Design drawings shall include a general arrangement of the proposed structure with plans, cross sections, elevations and dimensions, indicating all structural members with their respective sizes, material grades and special connections, and shall be sufficiently comprehensive to allow the detailing of all connections. Dimension figures in the drawings shall be deemed to be correct, even if the drawings are not to scale. No dimension shall be obtained from a drawing by scaling or determining the distance between lines or points by electronic means. Where necessary, the architectural or other drawings shall relevant drawings shall also be provided. If applicable the combinations of the forces to be resisted by connections and any cambers, eccentricities and other information required for the design of connections shall be provided.

Holding-down bolt/interface drawings shall show the base location, level, orientation and details of members in contact with concrete or other supporting material, the supporting material as such, and any interface devices such as HD bolts, cast-in items or pockets.

Fabrication drawings shall show all necessary details, dimensions, and all welding and welding inspection requirements to enable fabrication of components. The fabrication drawings shall show details of holes and fittings necessary for lifting and erecting components; such holes and fittings may remain part of the permanent structure. Holes shown in the fabrication drawings shall be as follows:

a) For ordinary bolts and HSFG bolts

Not exceeding 24 mm diameter: 2 mm greater than the bolt diameter.

Greater than 24 mm diameter: 3 mm greater than the bolt diameter.

b) For HD bolts

Less than 24 mm diameter: 6 mm greater than the bolt diameter.

From 24 mm to 36 mm diameter: 10 mm greater than the bolt diameter.

The spacing between holes for fasteners and the distance between holes and edges shall comply with the relevant requirements of SANS 10162-1 and SANS 10162-2.

Holding-down bolt details shall include washers with holes not more than 3 mm greater than the HD bolt diameter; and the size and thickness of a washer shall be appropriate to the bolt diameter and size of the hole.

Any machining requirements shall be clearly indicated in the fabrication drawings. The fabrication drawings shall indicate clearly those locations where holes shall only be made by drilling

Approval of such drawings will not release the Contractor from his responsibility for the accuracy of his drawings. Details of substitutions of profiles and alternative details must be submitted to the Engineer for approval. All designed members shall be of unbroken lengths and no splicing, jointing or welding to make up such lengths will be permitted.

All drawings shall be prepared in accordance with the recognized industry standards i.e. "The South African Institute of Steel Construction publication, ***South African structural steelwork detailing manual.***"

Revised drawings shall have a term added to the drawing and a description in the notes stating the changes that have been made and the date they were made. Furthermore, whenever possible, the most recent revisions to design drawings should be individually highlighted where they occur in the drawing.

After the erection of the steel structure "as erected" drawings shall be provided to the Employer's Agent Representative. The "as erected" drawings shall consist of one set of paper prints of all drawings which have been marked up after completion and acceptance of the steelwork, to reflect changes that have occurred. Such "as erected" drawings shall include:

- a) General arrangement drawings or erection mark drawings,
- b) Fabrication drawings,
- c) Drawings made after fabrication to show revisions, and
- d) The fabrication drawing register

The Structural Engineer shall be a professional person with the required qualifications and registered with the Engineering Council of South Africa (ECSA) as a professional Engineer or Technologist in the required field.

6.4 PRESERVATION OF STRUCTURAL STEELWORK

All surfaces of structural steelwork are to be thoroughly cleaned of all rust, scale, oil or grease, all in accordance with SABS Code of Practice 064 and then protected against corrosion as follows:

- a) Preparatory work:

Steel to be cleaned down in accordance with SABS Code of Practice 064.

All metal surface defects such as laminations and welding spatter shall be removed by grinding. Sharp edges, rags, burrs, etc. shall be rounded off before cleaning. After fabrication, but before erection, all steel surfaces to be scraped and wired brushed to Grade St 2 of Swedish Specification SIS 05 59 00-1967. Steelwork so prepared is not to be touched by bare hands – linen gloves are to be worn. Before priming, the surface shall be vacuum cleaned or dry brushed to remove all dust and debris.

b) Priming:

As soon as possible after surface preparation, the first two coats of red lead (SABS Specification 312, Type 2, Grade 1) or zinc phosphate (SABS Specification 1319) primer is to be applied. Each coat is to have a dry film thickness of at least 25 micron for red lead and 30 micron for zinc phosphate. A minimum of 24 hours between coats, or as recommended by the Manufacturer. Any damage to the primer during handling or erection is to be prepared by removing any possible rust etc. and patch repaired to make up the original film thickness. All traces of soluble salts and corrosive airborne contaminants shall be thoroughly removed with potable water and allowed to dry prior to finishing.

c) Finishing:

After erection, apply two coats of alkyd structural steel paint complying with SABS Specification 684, Type B, in accordance with the Manufacturer's recommendations. Each coat is to have a minimum dry film thickness of 30 microns.

d) General:

No surface preparation or painting is to be performed in adverse weather conditions. Edges are to be stripe painted before application of paint over the whole surface. Back to back sections and areas rendered inaccessible for painting after erection are to receive the full paint system before erection or fixing.

6.5 INSPECTION

The Contractor shall notify the Employer's Agent Representative and design engineer of the completion of the fabrication of steelwork at the Steel Fabricator's works to enable them to make inspections if they so desires.

The Structural Engineer appointed by the Contractor shall be responsible for the construction inspections during the manufacturing (Which shall include but not be limited to workmanship with regard to the material identification, handling of steel, cutting and shaping of steel elements, machining-, dressing- and holing of steel elements, assembly including welding, finishing of steel elements with the required paint cover) and erection of the portal frame structure including the concrete footings, steel structure, and sheet covering of the roof and shall provide the Employer's Agent Representative with a certificate of compliance to the specifications at the completion of the structure.

PC 6 MEASUREMENT AND PAYMENT

Item	Unit
-------------	-------------

PC 6.1 Professional fees for the Structural Engineer	Sum
--	-----

The unit of measurement shall be the Sum Total of the professional fees.

The tendered rates for the professional fees shall be the full compensation of all the professional services required for the detail survey of the terrain, geotechnical investigation for foundation design of concrete footings, detail design of steel structure as per the drawings of the required structure and full construction supervision of the manufacturing and erection of the steel structure. The rates shall include full compensation for all professional fees, traveling time, disbursement costs and the supply of detailed complete set of design and shop drawings and copies thereof for approval, construction supervision and the issue of a certificate of compliance that the structure has been erected to the set specifications.

Item	Unit
-------------	-------------

PC 6.2 Steel portal frame structure.....	Sum
--	-----

The unit of measurement shall be the Sum Total for the Steel Portal Frame Structure complete with all columns, baseplates, trusses, purlins, galvanized sheet covering, etc.

The tendered rate for the steel portal frame structure shall include full compensation for all materials, including the cutting, waste, manufacturing of elements, baseplates, anchor bolts, bolts and nuts, bracing, purlins, galvanized sheet covering, etc. for the complete steel portal frame structure as per the Structural Employer’s drawings delivered at site and erected to the levels as indicated on the drawings. All surfaces of steelwork are to be preserved as prescribed in Clause 6.4 above before leaving the workshop.

7 SECTION 7: METALWORK

7.1 STEEL

All structural steelwork shall be of mild steel complying with the requirements of SABS Code of Practice 0162 for Structural Steel in General Building Construction.

7.2 PRESERVATION OF STEELWORK

All surfaces of structural steelwork are to be thoroughly cleaned of all rust, scale, oil or grease, all in accordance with SABS Code of Practice 064 and then protected against corrosion as follows:

a) Preparatory work:

Steel to be cleaned down in accordance with SABS Code of Practice 064.

All metal surface defects such as laminations and welding spatter shall be removed by grinding. Sharp edges, rags, burrs, etc. shall be rounded off before cleaning. After fabrication, but before erection, all steel surfaces to be scraped and wired brushed to Grade St 2 of Swedish Specification SIS 05 59 00-1967. Steelwork so prepared is not to be touched by bare hands – linen gloves are to be worn. Before priming, the surface shall be vacuum cleaned or dry brushed to remove all dust and debris.

b) Priming:

As soon as possible after surface preparation, the first two coats of red lead (SABS Specification 312, Type 2, Grade 1) or zinc phosphate (SABS Specification 1319) primer is to be applied. Each coat is to have a dry film thickness of at least 25 micron for red lead and 30 micron for zinc phosphate. A minimum of 24 hours between coats, or as recommended by the Manufacturer. Any damage to the primer during handling or erection is to be repaired by removing any possible rust etc. and patch repaired to make up the original film thickness. All traces of soluble salts and corrosive airborne contaminants shall be thoroughly removed with potable water and allowed to dry prior to finishing.

c) Finishing:

After erection, apply two coats of alkyd structural steel paint complying with SABS Specification 684, Type B, in accordance with the Manufacturer's recommendations. Each coat is to have a minimum dry film thickness of 30 microns.

d) General:

No surface preparation or painting is to be performed in adverse weather conditions.

Edges are to be stripe painted before application of paint over the whole surface. Back to back sections and areas rendered inaccessible for painting after erection are to receive the full paint system before erection or fixing.

7.3 MANUFACTURED STEELWORK: GENERAL:

a) Welded joints:

Welding is to be done electrically in the most up to date manner by skilled workmen and cleaned off on completion.

All welding is to be carried out using welding rods of the same chemical composition as the tubes, rods, bars, etc. to be welded. All exposed welds are to be finished off clean and smooth.

Welding to all exposed edges is to be continuous fillet welding unless otherwise described.

b) Protection:

No scaffolding shall be allowed to rest on or be fixed to steel windows, doors, frames, etc. in any way.

7.4 PRESSED STEEL DOOR FRAMES

Pressed steel door frames shall be of welded "one piece" construction, all in accordance with SABS Specification 1129.

STANDARD STEEL DOOR FRAMES

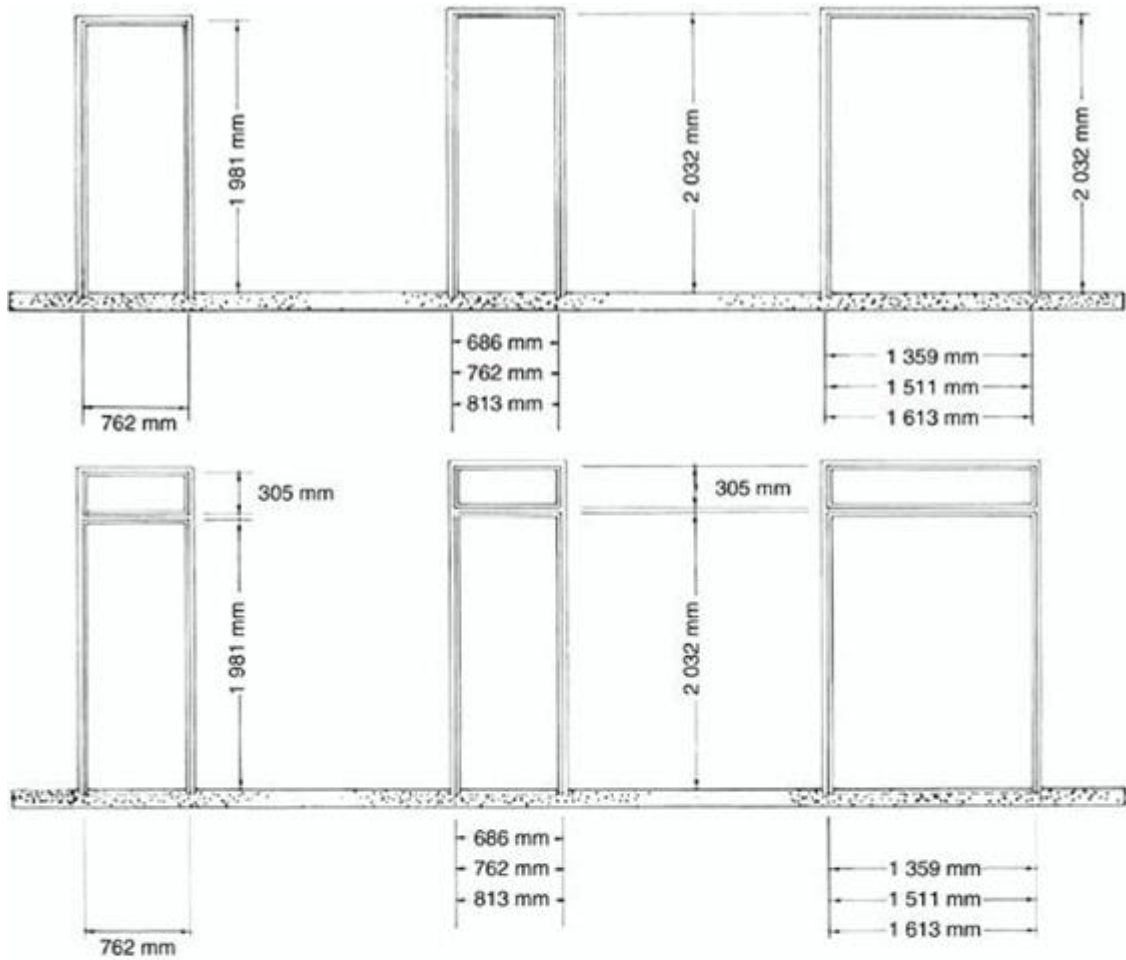

Fanlight Type Frames

Sizes are taken into rebates at head and jambs and to finished floor level. All rebates are up to 44 mm nominal door thickness. Whether inward or outward opening, the "hand" of a single door should be determined by the side on which the hinges are fitted, when viewed from the hinge side.

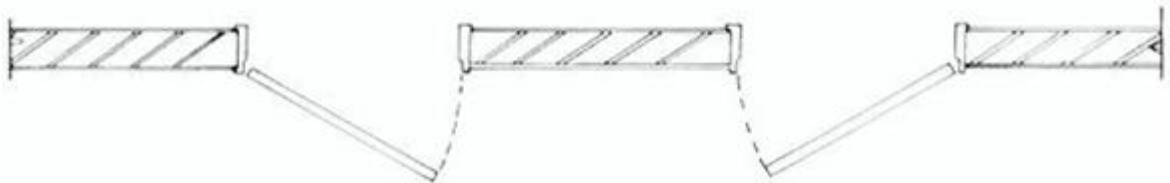

Profiles are as published in SABS Specification N01129 - 1977.

Frames are stocked for two common wall thickness, 115 mm and 230 mm. The 115 mm profile is formed from 1,2 mm steel with single rebate. The 230 mm profile is formed from 1,2 mm steel when double rebated and 1,6 mm when single rebate.

STEEL COMBINATION DOORS AND FRAMES

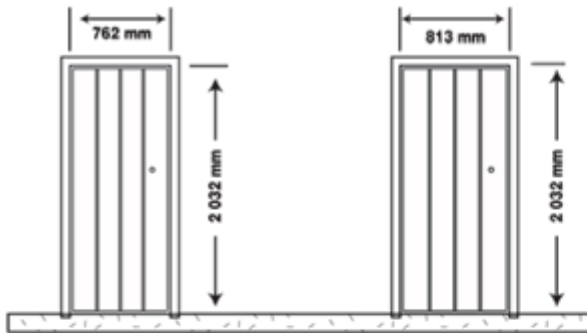

Widths are into rebates of frames. Heights are from finished floor to head rebate.

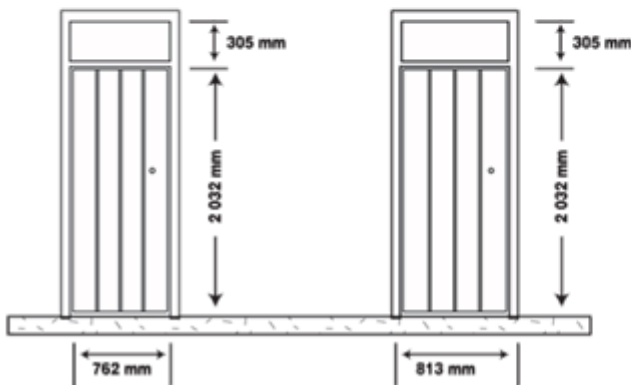

Steel panels are braced to give additional rigidity.

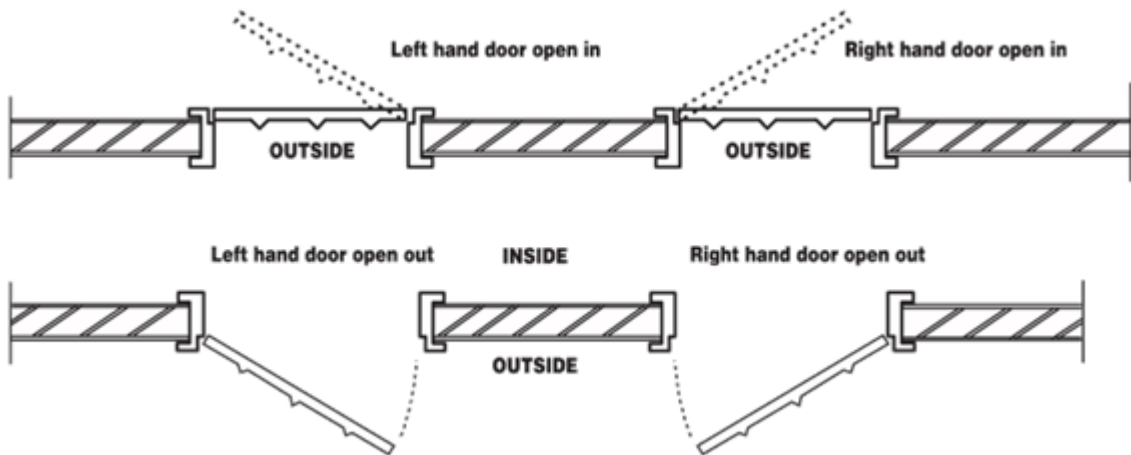

7.5 STEEL ROLLER SHUTTERS

Roller shutter doors shall be of approved manufacture, fit flat against surface of opening and consist of curtain, vertical guides and overhead mechanism.

The curtain is to be formed of machine rolled interlocking slats with malleable iron end stocks riveted or spot welded onto alternate ends. The bottom slat is to be fitted with heavy angle iron riveted on and the vertical edges to run in heavy channel guides bolted to wall.

The overhead mechanism is to be enclosed in a canopy formed of sheet steel. The whole is to be primed before leaving the Manufacturer's works.

PUSH UP TYPE: The canopy and curtain shall be manufactured from 0,91 mm thick metal with 50 mm wide slats, for curtain operating on a horizontal steel barrel shaft of ample strength and balanced by a high grade tempered steel adjustable helical spring, mounted on casting with ball bearings and provided with fusible link, a pair of 100 mm pull handles and a heavy hasp and staple with a 50 mm padlock as Sample 32.

GEAR OPERATED: Gear operated type roller shutter doors shall be manufactured from 1,22 mm thick metal with 75 mm wide slats and operated by means of bevel gears driven by a vertical shaft operated by means of a detachable handle.

7.6 STAINLESS STEEL. ALUMINIUM, BRONZE. ETC.:

7.6.1 GENERAL:

The work shall be constructed of the best quality materials (high tensile in the case of extruded aluminium sections), all in accordance with the detail drawings, free from flaws, hammer marks and other defects.

The whole shall be framed together in the strongest possible manner with all joints reinforced as necessary and neatly finished off.

Screws are to be of stainless steel and shall not be visible, except under special circumstances and where used to fix glazing beads.

Glazing beads and other fixing or finishing strips shall be mitred at angles and secured with raised headed screws spaced at not more than 150 mm centres.

Metals, other than stainless steel, used in the fabrication of aluminium work must be kept from direct contact with the aluminium by means of an approved method.

7.6.2 FINISH AND PROTECTION:

Surfaces shall be finished as specified and none is to be fixed in position until it has been inspected and approved. Aluminium work, except as otherwise described, is to have a natural anodised finish.

Descriptions (prices) shall be deemed to include coating finished surfaces with a thick coating of lacquer or other approved materials as protection from damage by contact with brick, concrete, plaster, etc.

Finished surfaces shall be cleaned down to a consistent colour and texture equal to a sample approved by the Representative/Agent before any work is commenced.

7.6.3 DESIGN:

No deviation may be made from the general requirements or dimensions, but improvements in construction and design affecting neatness, strength, durability or efficient work may be introduced, but only after approval by the Representative/Agent.

The detail drawings are for guidance only and Tenderers are permitted to offer their own sections, providing they are similar to those detailed. Full particulars and detailed drawings must be submitted with any alternative offer and such drawings and details are to be approved before manufacture is commenced. Every facility must be given for the work to be inspected during manufacture,

7.7 STEEL WINDOWS

a) General requirements:

Stock residential and industrial type steel windows shall comply with the requirements of SABS Specification 727.

Suitable weather bars shall be provided to bottom of opening in and vertically pivot hung ventilators and also to the bottom of all opening out ventilators where they occur above other ventilators and elsewhere as may be required to render the opening sections watertight.

Windows and components, shall before leaving the Manufacturer's workplace, be cleaned by acid pickling, rinsing and drying all as laid down in SABS Code of Practice 064, to remove all scale, rust, grease, oil and foreign matter and then be primed with red oxide zinc chromate primer complying with the requirements of SABS Specification 909, applied by dipping or by means of a spray gun.

Windows shall be of "one pietse" construction.

Windows shall be fitted with brass handles, stays, catches and other fittings as later described having a polished finish. The fittings shall be fixed in such a way as to be removable after the windows have been glazed.

After the windows have been built in, but before being glazed, they shall be overhauled, adjusted as necessary and left in good order.

b) Construction:

The various types of windows shall be constructed as follows:

Stock residential type windows:

Stock residential type windows shall be of the types shown on drawings, constructed of standard 25mm mild steel sections with metal not less than 3mm thick.

Side hung ventilators:

Each ventilator shall be hung on steel hinges having brass pins complete with casement fastener and sliding stay.

Top hung ventilators:

Each ventilator shall be hung on hinges as above complete with combined fanlight stay and fastener, size 200mm for one pane high ventilators and size 250mm for two pane high ventilators.

G – TYPE RESIDENTIAL OPEN OUT – HEIGHT 0.359m

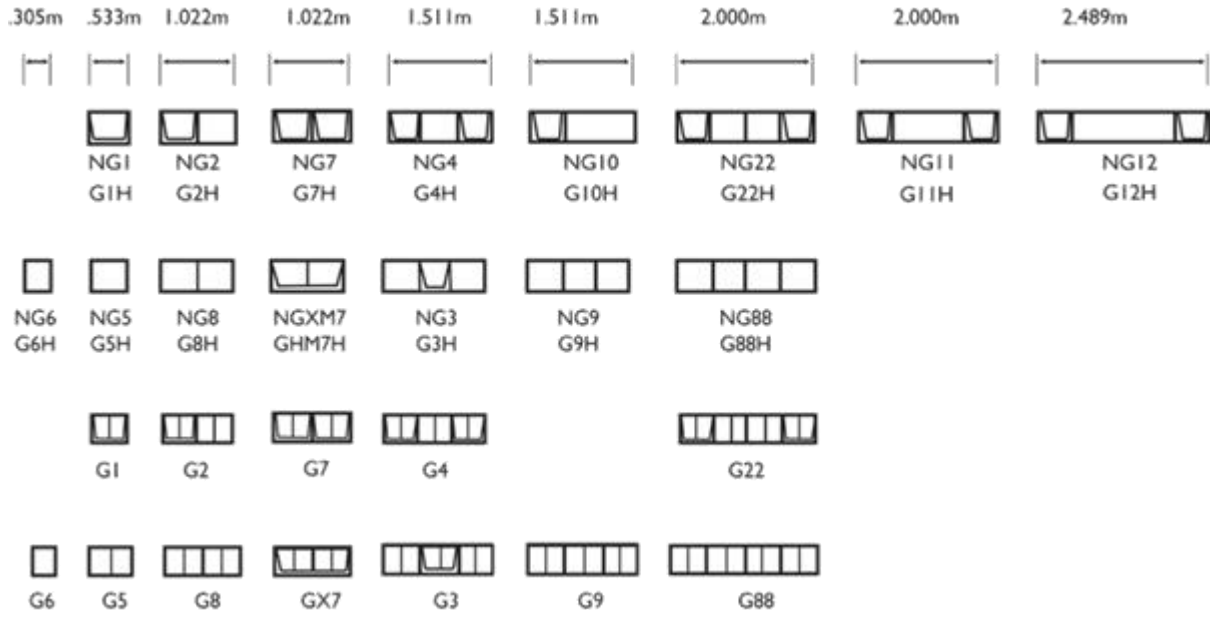

ES TYPE (TOP HUNG)

ES TYPE (SIDE HUNG)

RESIDENTIAL OPEN OUT – HEIGHT 0.654m

.305m	.533m	1.022m	1.022m	1.511m	1.511m	2.000m	2.000m	2.489m
NET6	NE1	NE2	NE7	NE4	NE10	NE22	NE11	NE12
NES6	NES1	NES2	NES7	NES4	NES10	NES22	NES11	NES12
NE6	NE5	NE8	NEXM7	NE3	NE9	NE88		
NE6F	NESF		NEX7	NES3	D9H	D5H		
ET6H	E1H	E2H	E7H	E4H	E10H	E22H	E11H	E12H
ES6H	ES1H	ES2H	ES7H	ES4H	ES10H	ES22H	ES11H	ES12H
E6H	E5H	E8H	EX7MH	E3H	E9H	E88H		
E6FH	ESFH		EX7H	ES3H				
ET6	E1	E2	E7	E4		E22		
ES6	ES1	ES2	ES7	ES4		ES22		
E6	E5	E8	EX7	E3		E88		
E6F	ESF		ES3	E9				

C TYPE RESIDENTIAL OPEN OUT – HEIGHT 0.949m

.305m	.533m	1.022m	1.022m	1.511m	1.511m	2.000m	2.000m	2.489m
NC6	NC5	NC8		NC3	NC9	NC88		
NC56	NC1	NC2	NC7	NC4	NC10	NC22	NC11	NC12
NC6F	NC5F	NC2F		NC4F	NC10F	NC22F	NC22F	NC12F
C6H	C5H	C8H		C3H	C9H	C88H		
CS6H	C1H	C2H	C7H	C4H	C10H	C22H	C11H	C12H
C6FH	C5FH	C2FH		C4FH	C10FH	C22FH	C11FH	C12FH
C6	C5	C8		C3	C9	C88		
CS6	C1	C2	C7	C4		C22		
C6F	C5F	C2F		C4F		C22F		

D TYPE RESIDENTIAL OPEN OUT – HEIGHT 1.245m

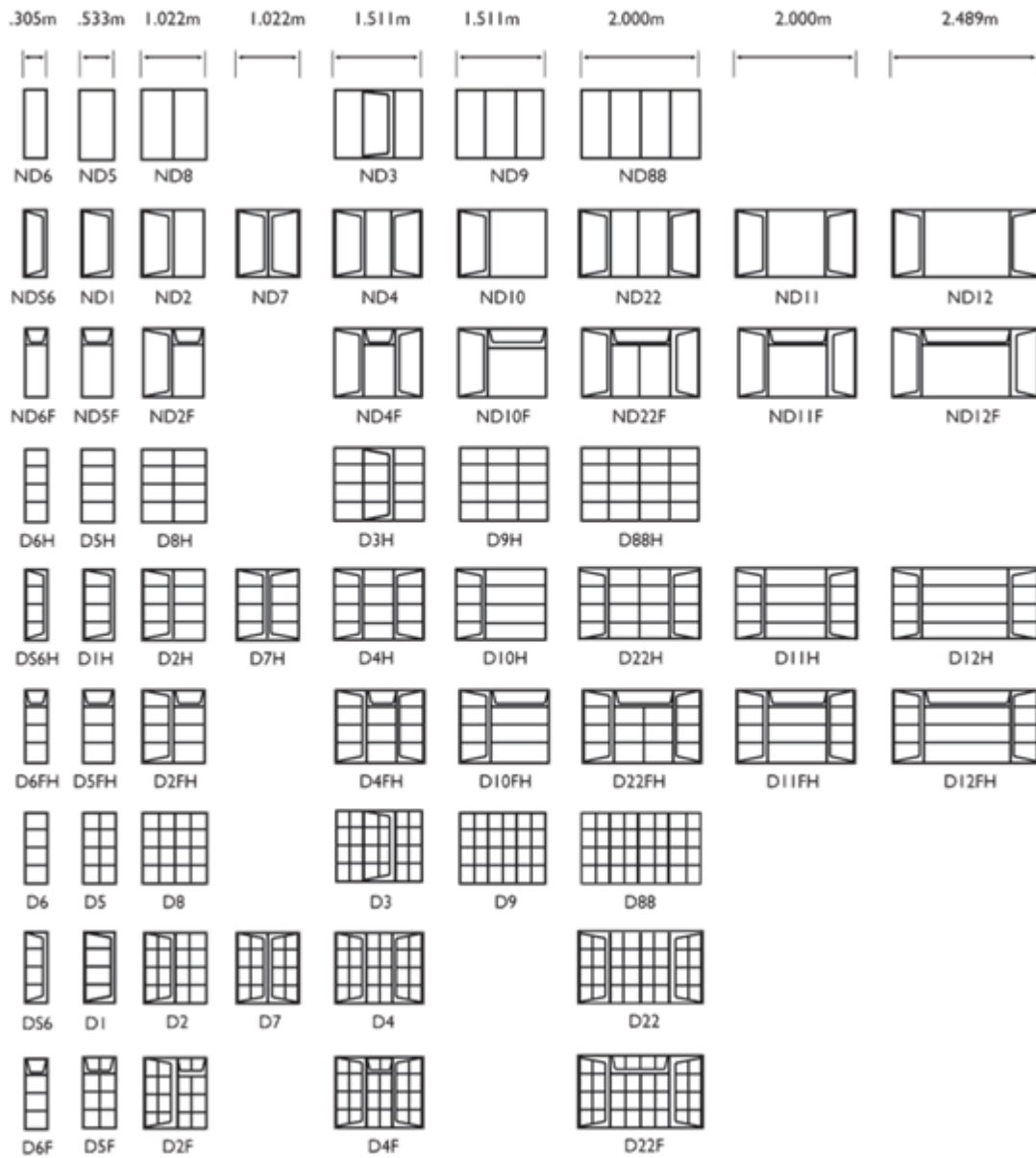

D 50 TYPE RESIDENTIAL OPEN OUT – HEIGHT 1.540m

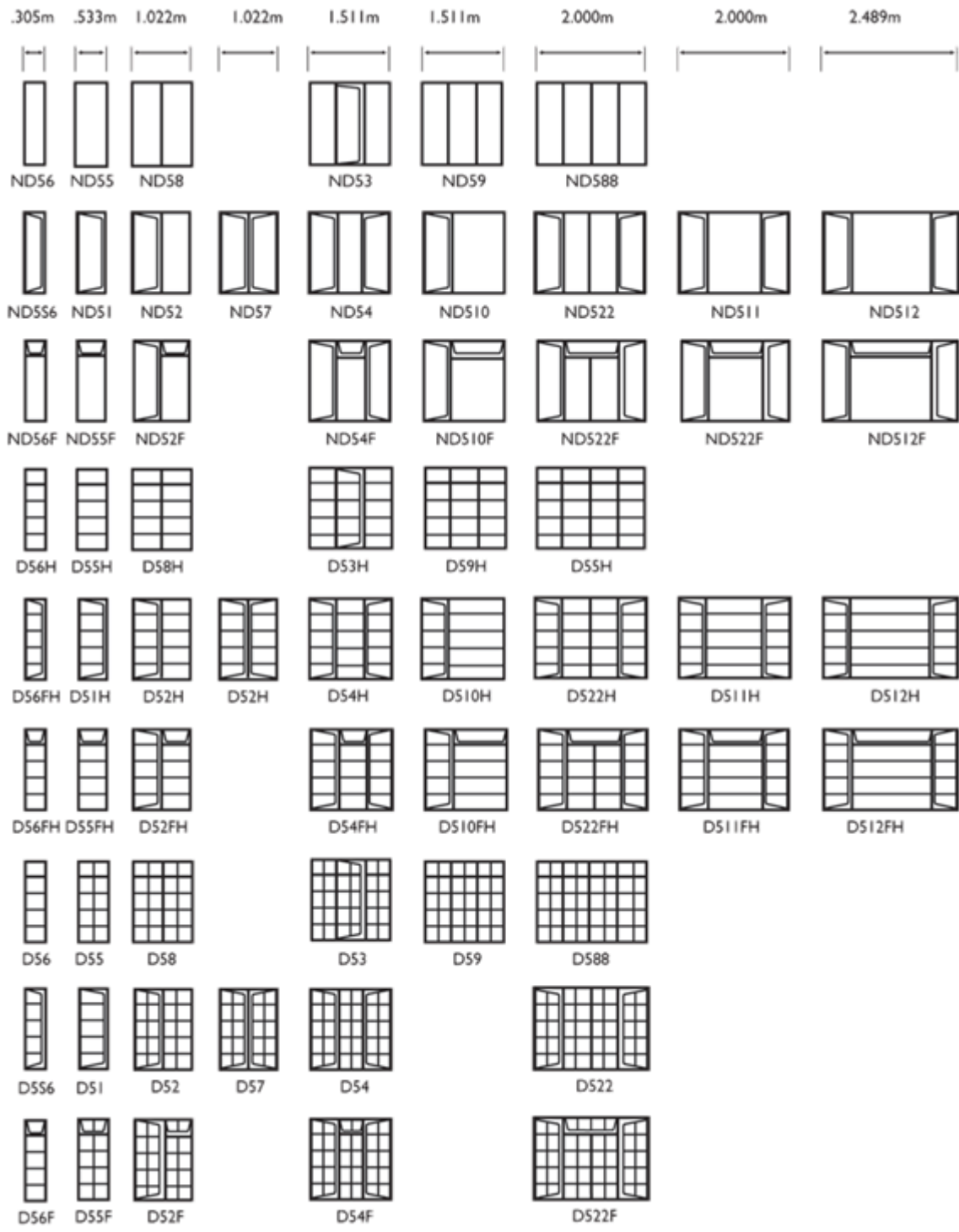

D/S TYPE RESIDENTIAL OPEN OUT – HEIGHT 1.264m

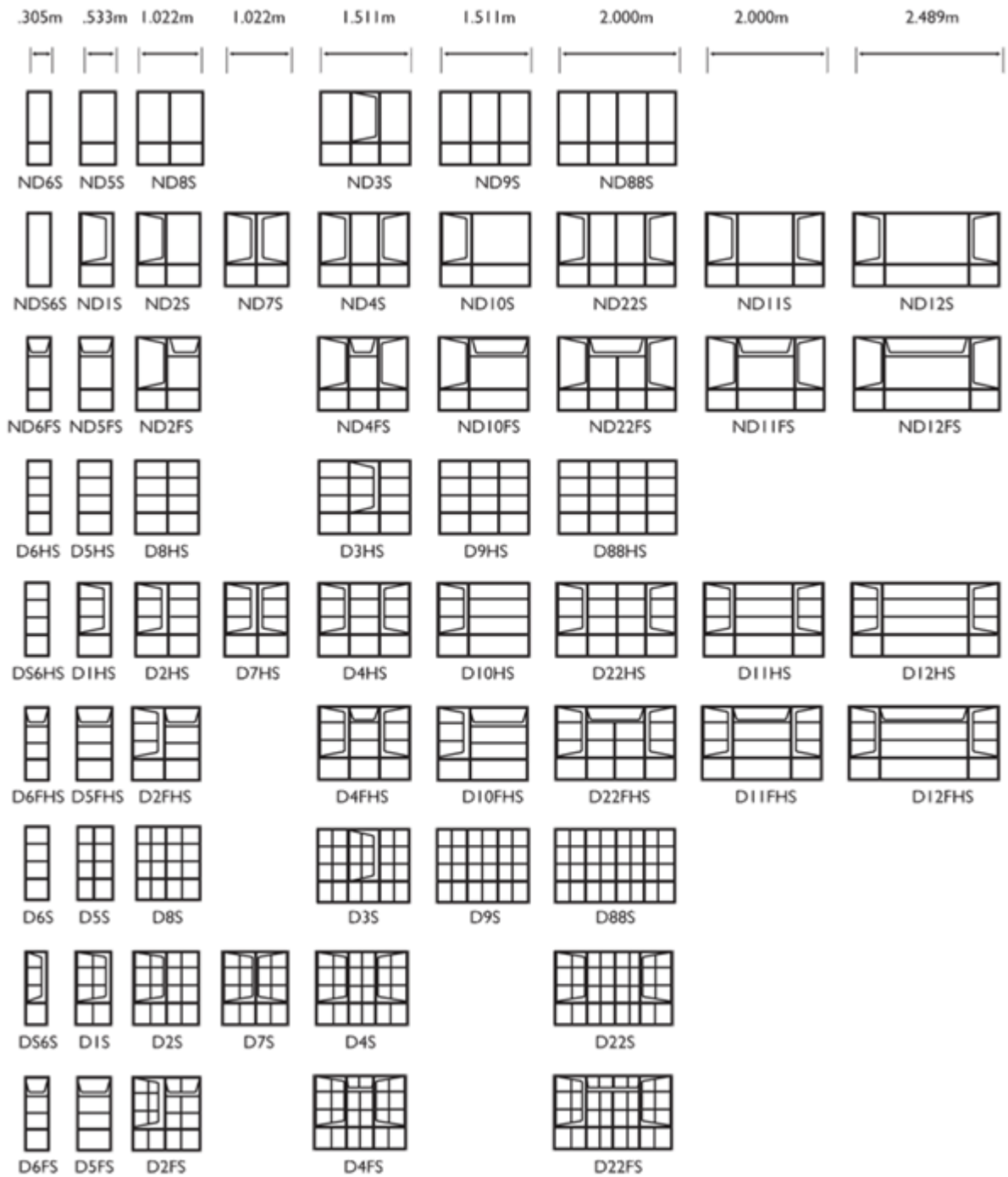

D 50/S TYPE RESIDENTIAL OPEN OUT – HEIGHT 1.559m

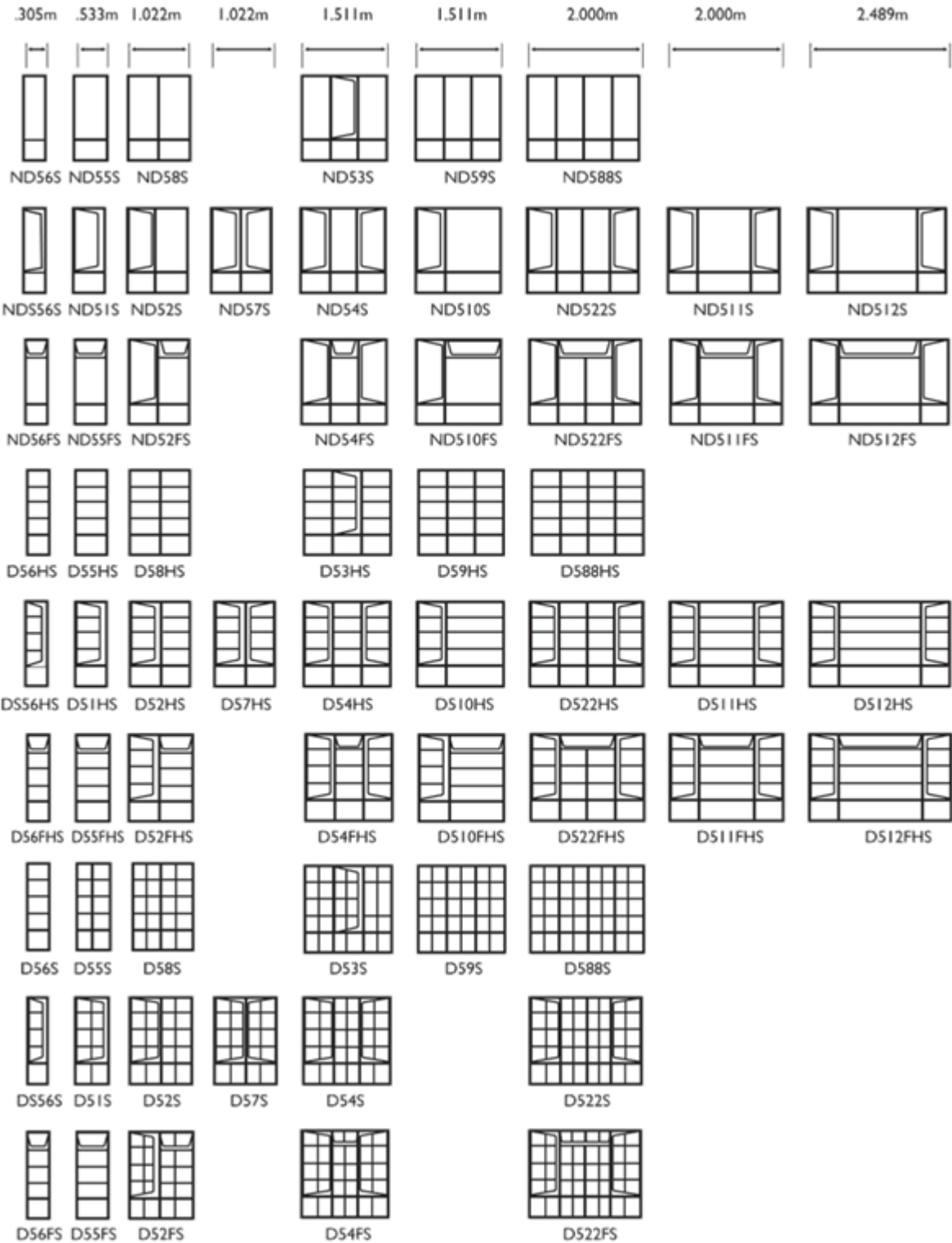

G/C TYPE RESIDENTIAL OPEN OUT – HEIGHT 1.264m

.533m	.533m	1.022m	1.511m	1.511m	2.000m	2.489m
NG1NC1	NG5NC1	NG2NC2	NG3NC3	NG4NC3	NG22NC22	
NG1NC5	NG5NC5	NG7NC7	NG3NC4	NG4NC4	NG88NC88	
		NG8NC8	NG9NC9	NG10NC10	NG11NC11	NG12NC12
G1HC1H	G5HC1H	G2HC2H	G3HC3H	G4HC3H	G22HC22H	
G1HC5H	G5HC5H	G7HC7H	G3HC4H	G4HC4H	G88HC88H	
		G8HC8H	G9HC9H	G10HC10H	G11HC11H	G12HC12H
G1C1	G5C1	G2C2	G3C3	G4C3	G22C22	
G1C5	G5C5	G7C7	G3C4	G4C4	G88C88	
		G8C8	G9C9			

G/D TYPE RESIDENTIAL OPEN OUT – HEIGHT 1.559m

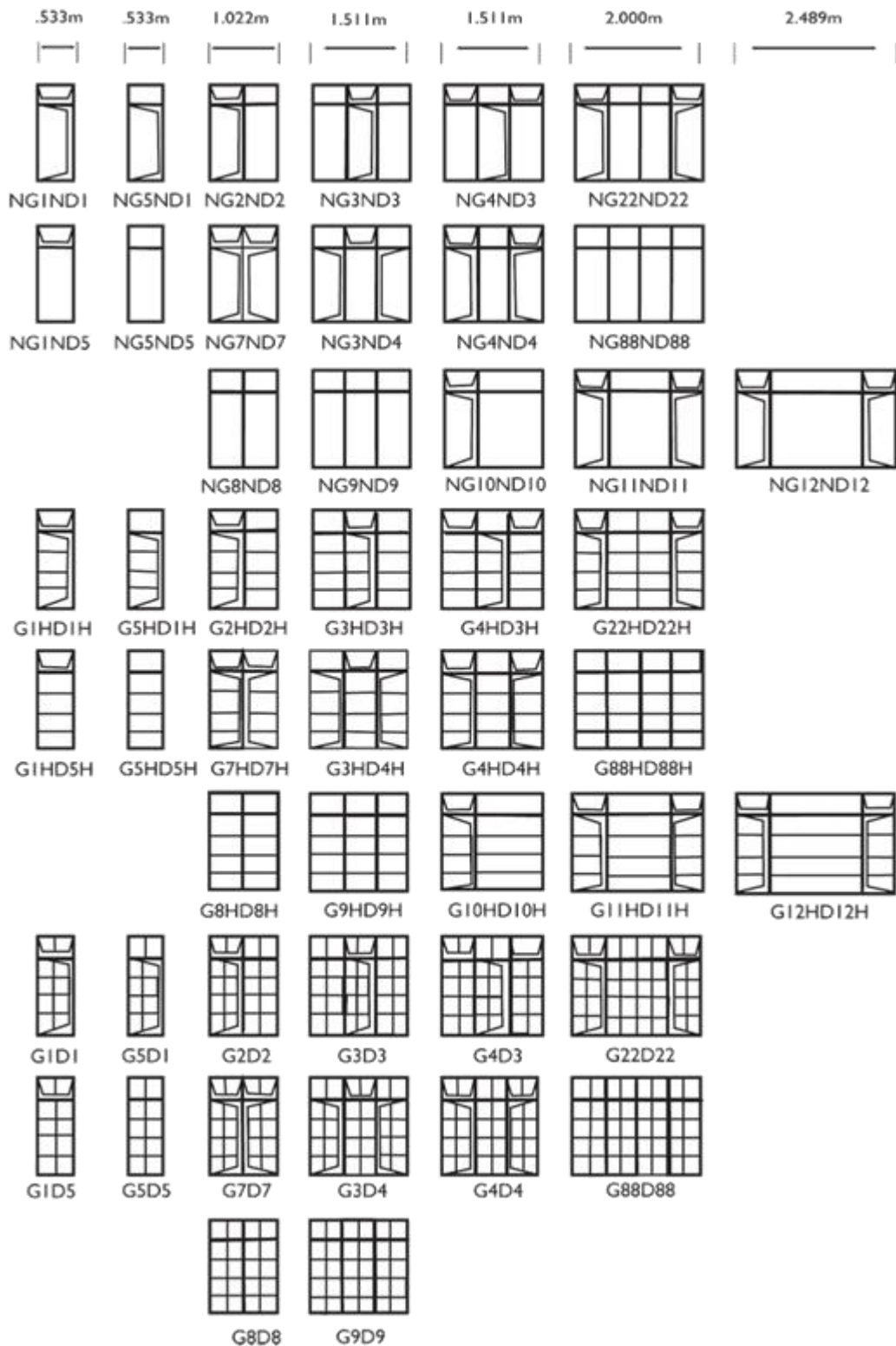

G/D 50 TYPE RESIDENTIAL OPEN OUT – HEIGHT 1,854m

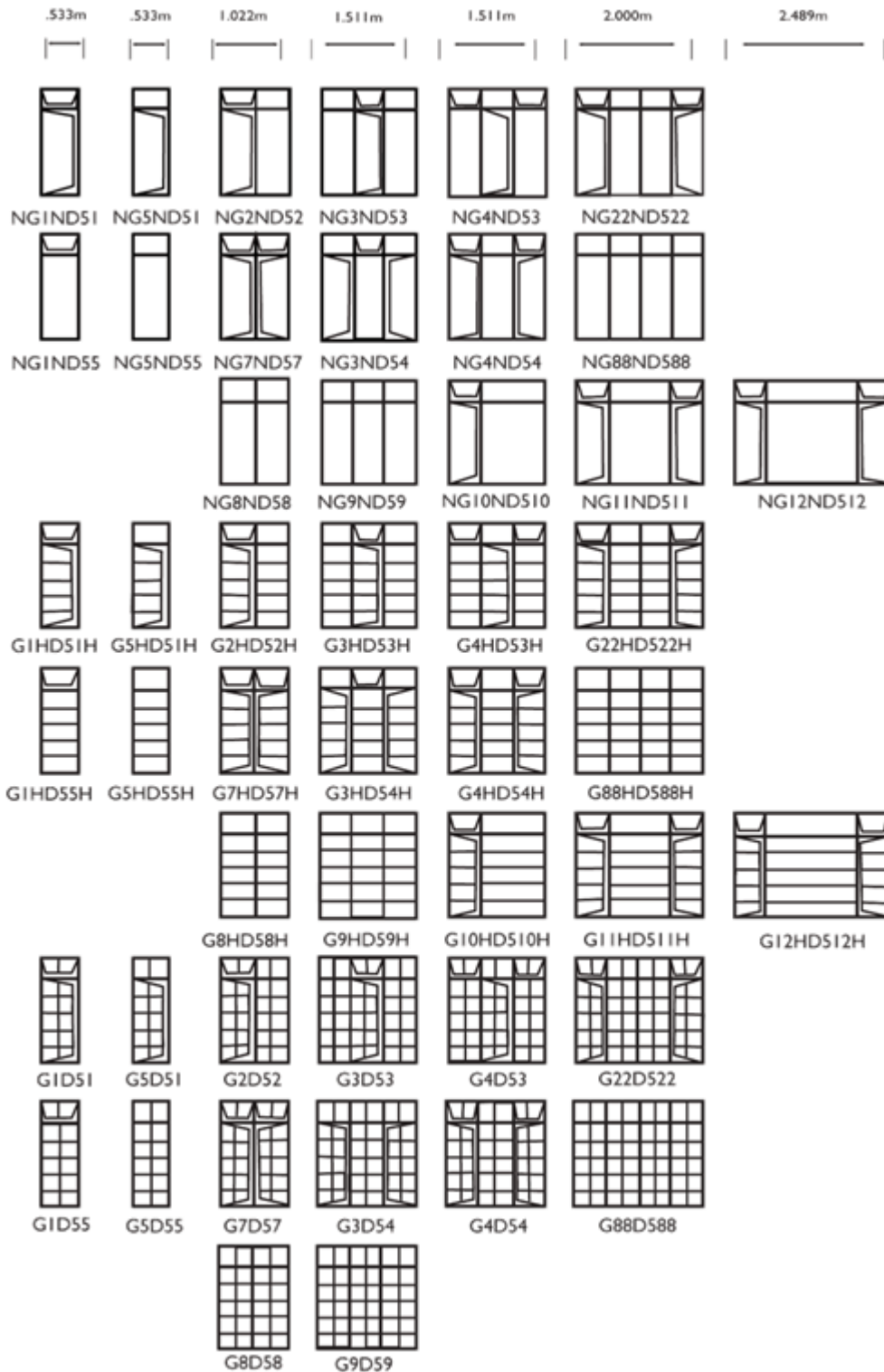

E/C TYPE RESIDENTIAL OPEN OUT – HEIGHT 1.559

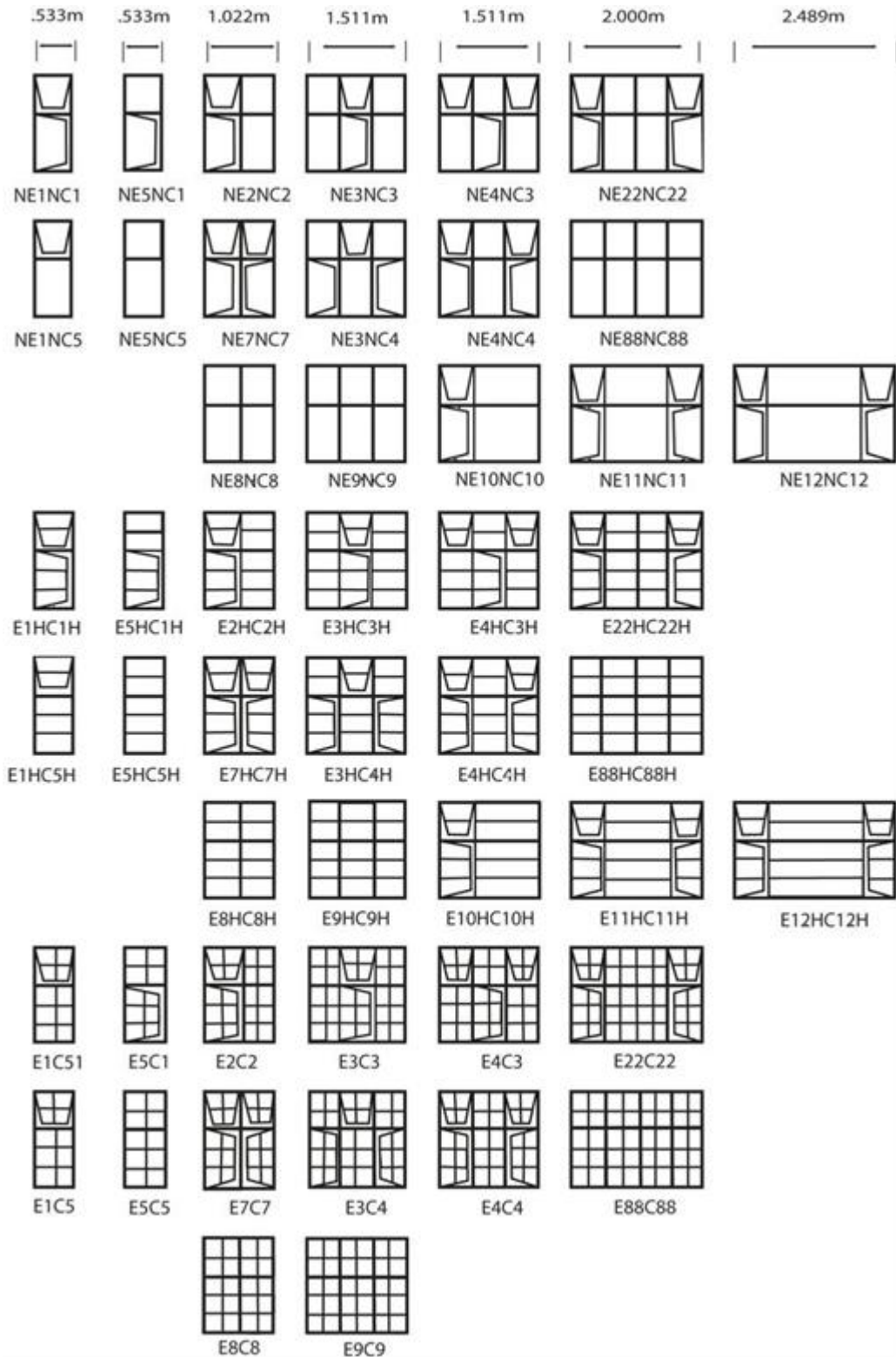

E/D TYPE RESIDENTIAL OPEN OUT – HEIGHT 1.854m

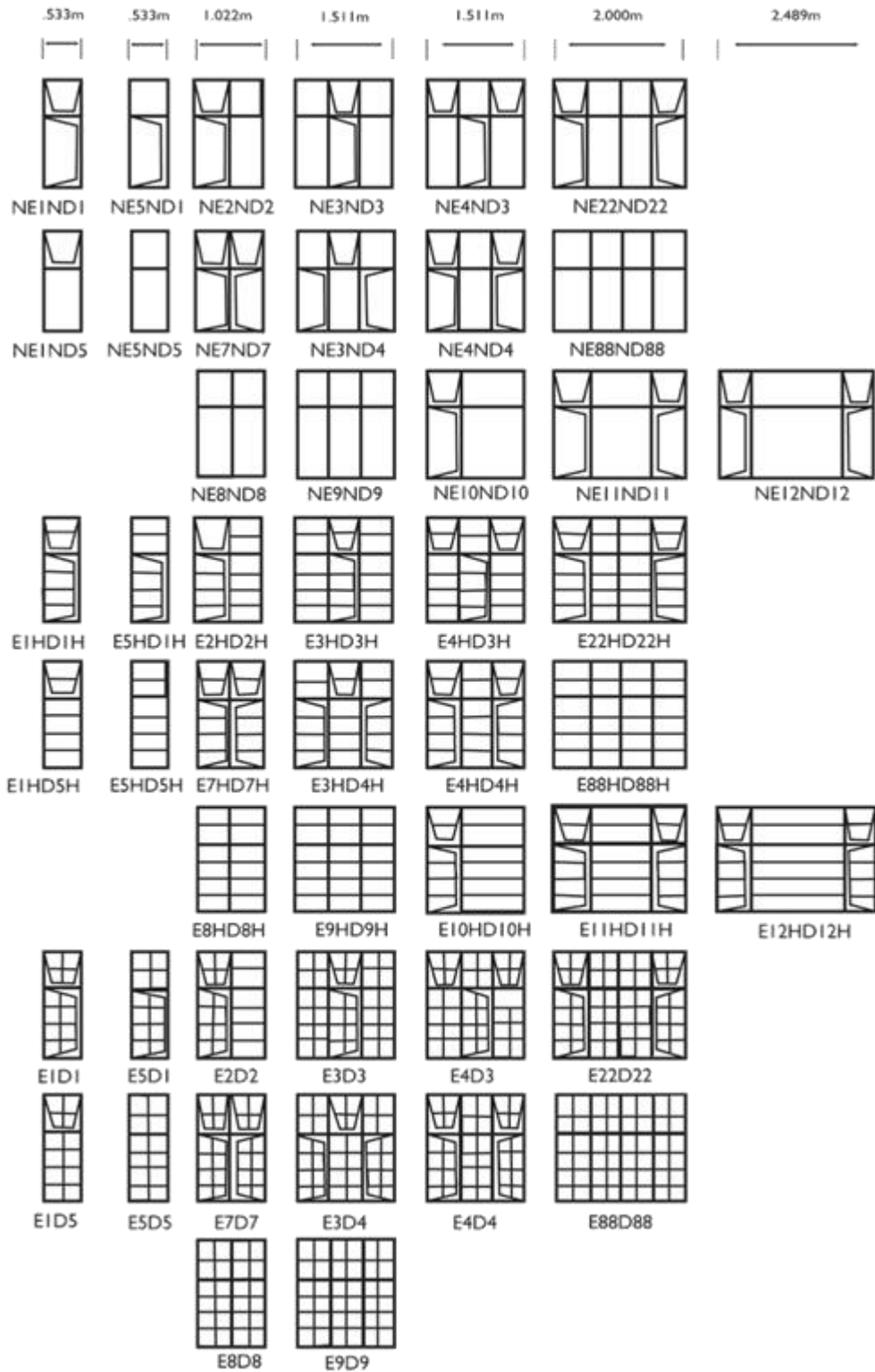

Z TYPRRESIDENTIAL OPEN OUT

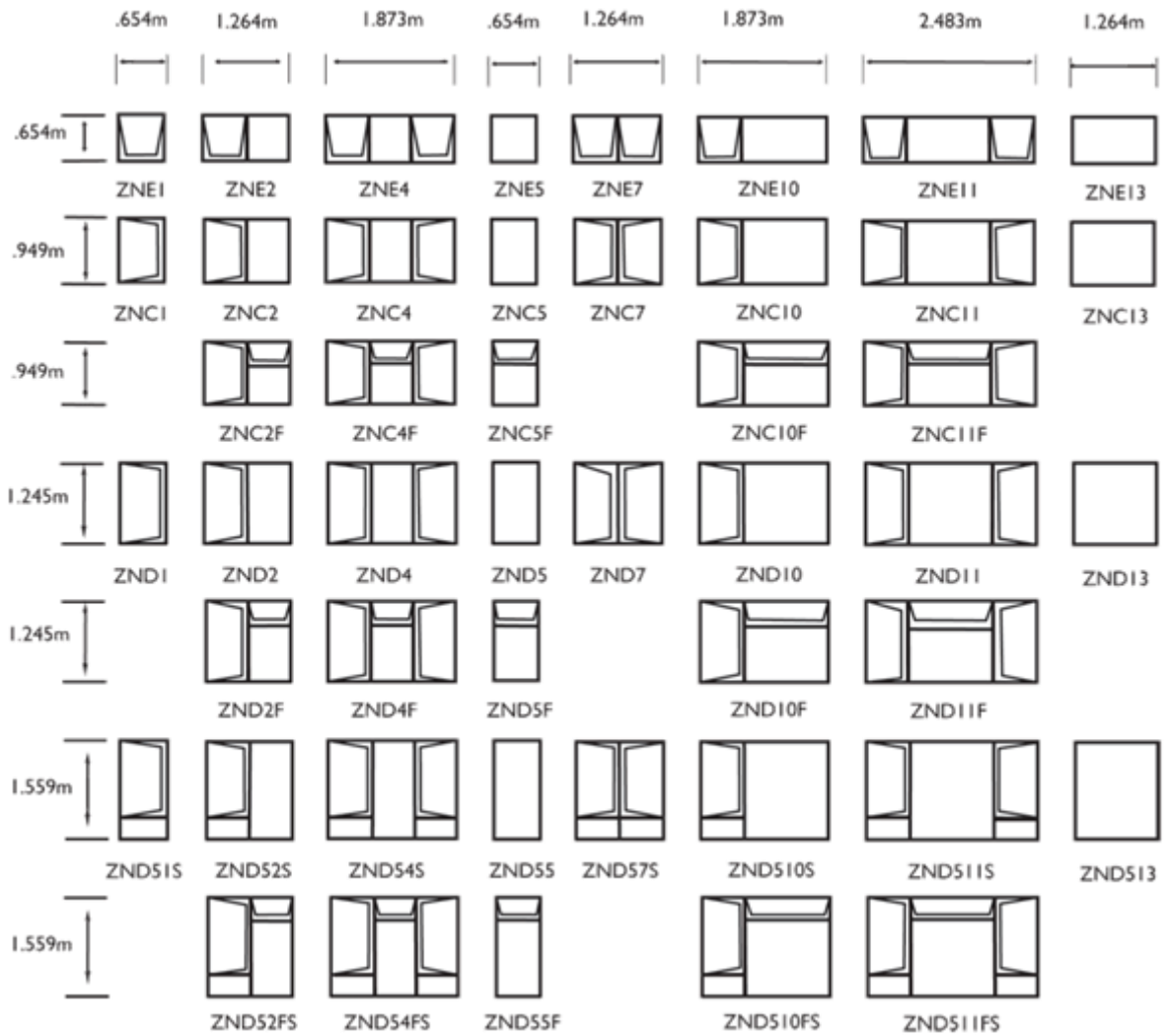

“TD” AWNING TYPE RESIDENTIAL OPEN OUT



“TD” AWNING TYPE RESIDENTIAL OPEN OUT

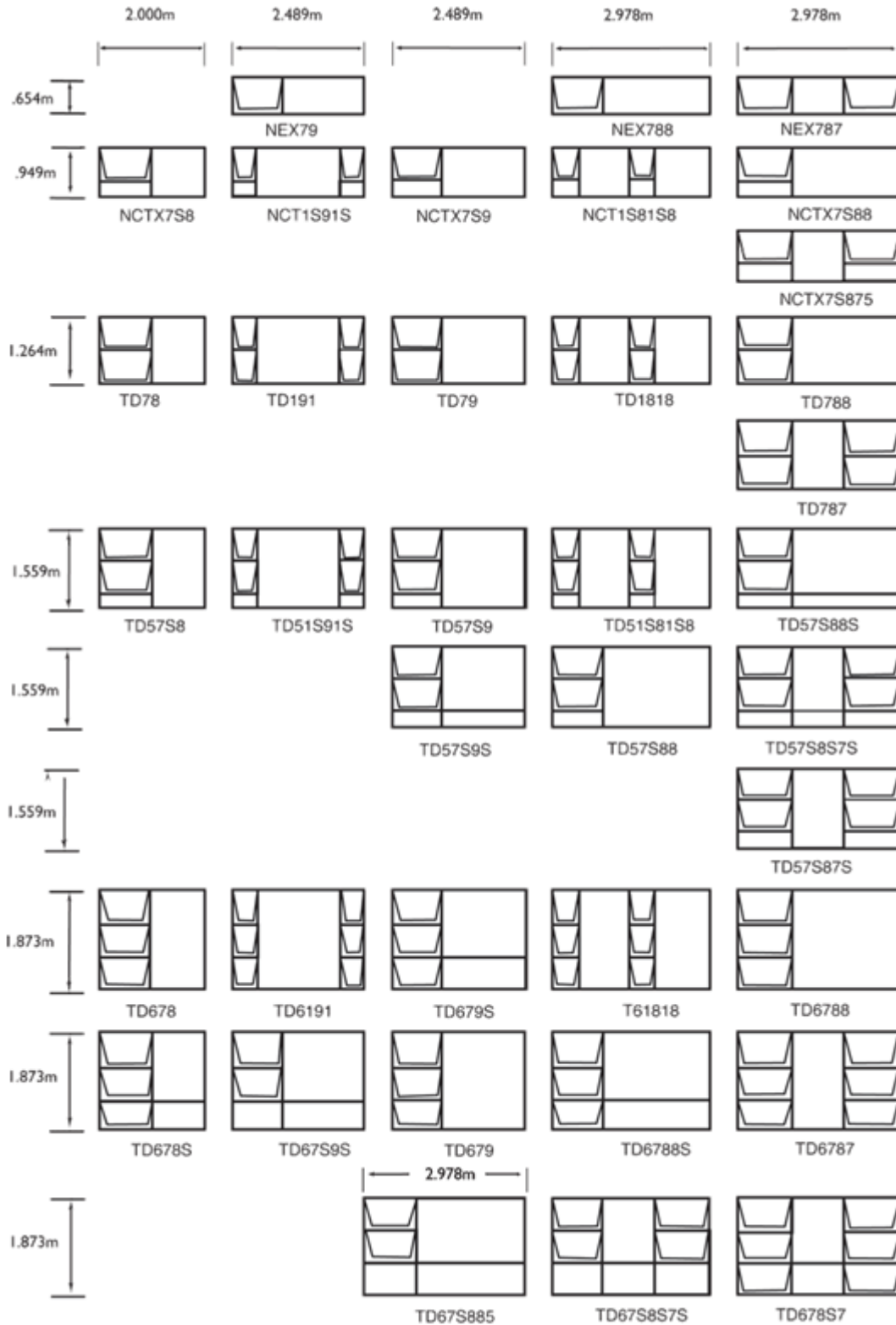

SCHOOL TYPE WINDOWS

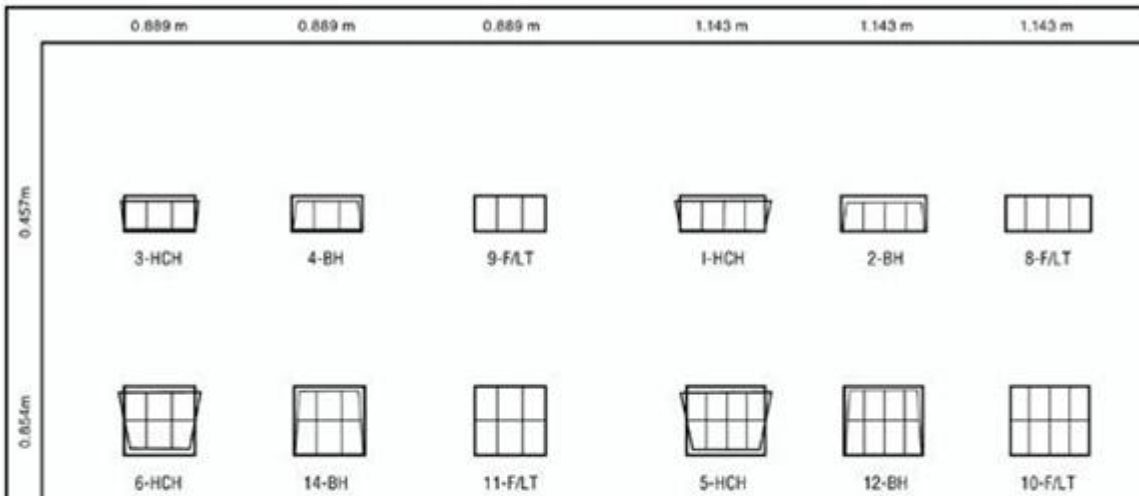

Up to seven panes in height, vertical composite school windows are made in one piece construction in units 0,889 m or 1,143 m wide. Above this height coupling transomes are required. Horizontal composites are formed by coupling 0,889 m or 1,143 m wide units together with mullions.

EXAMPLE COMPOSITE TYPES

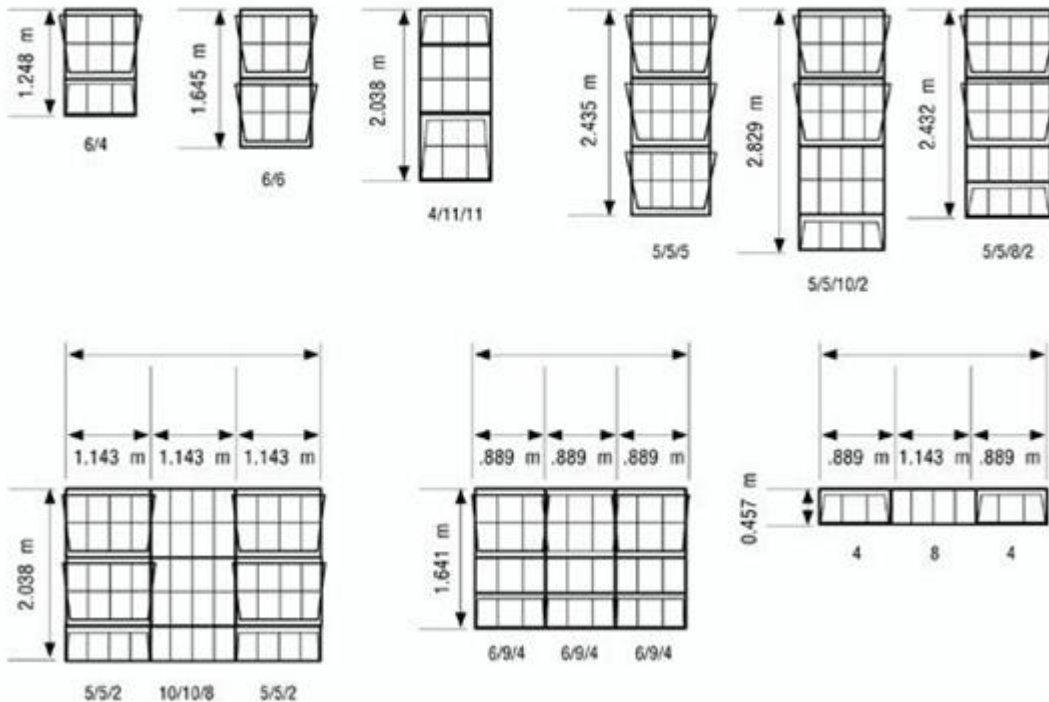

“SS” INDUSTRIAL TYPE

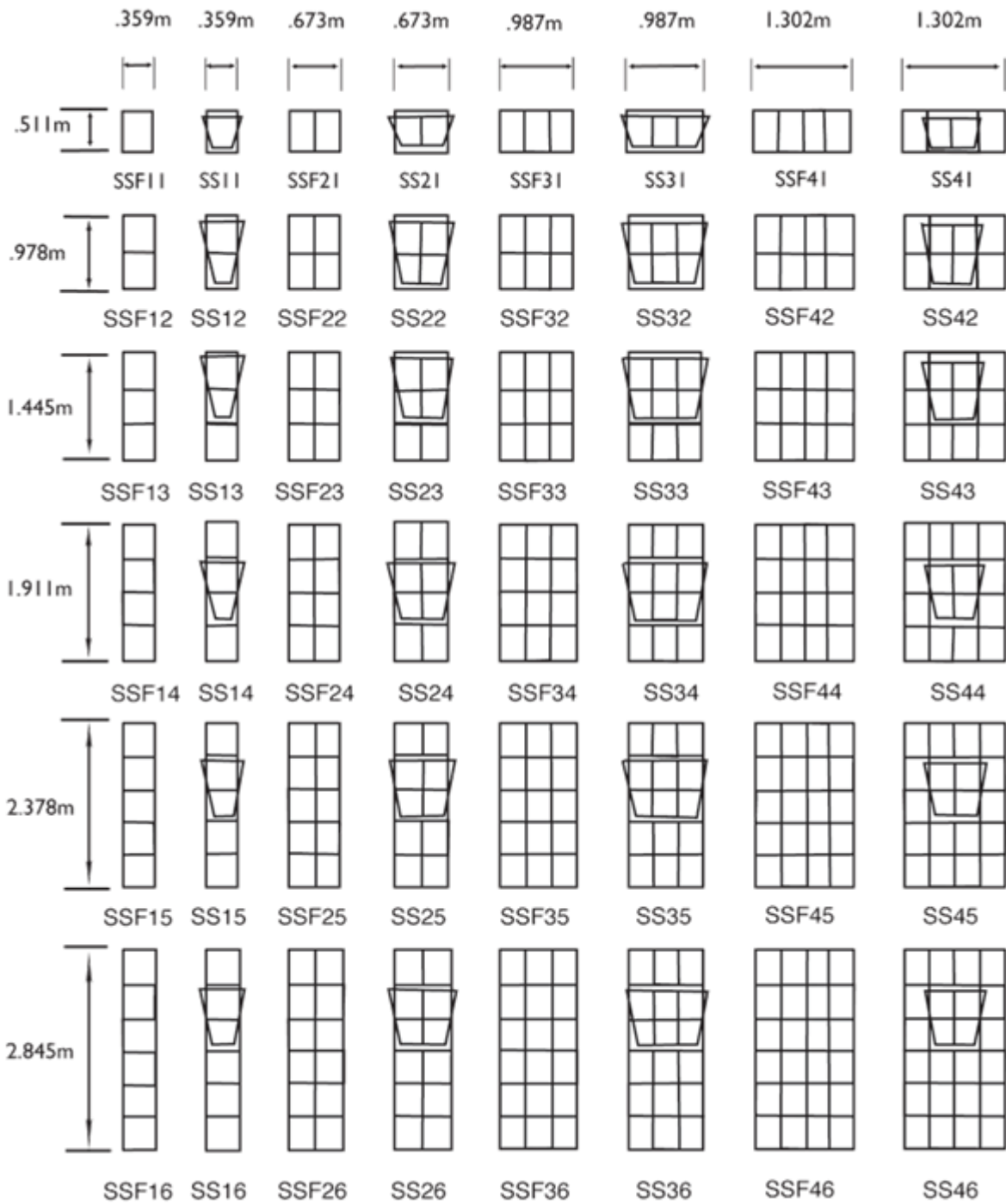

“SS” INDUSTRIAL TYPE

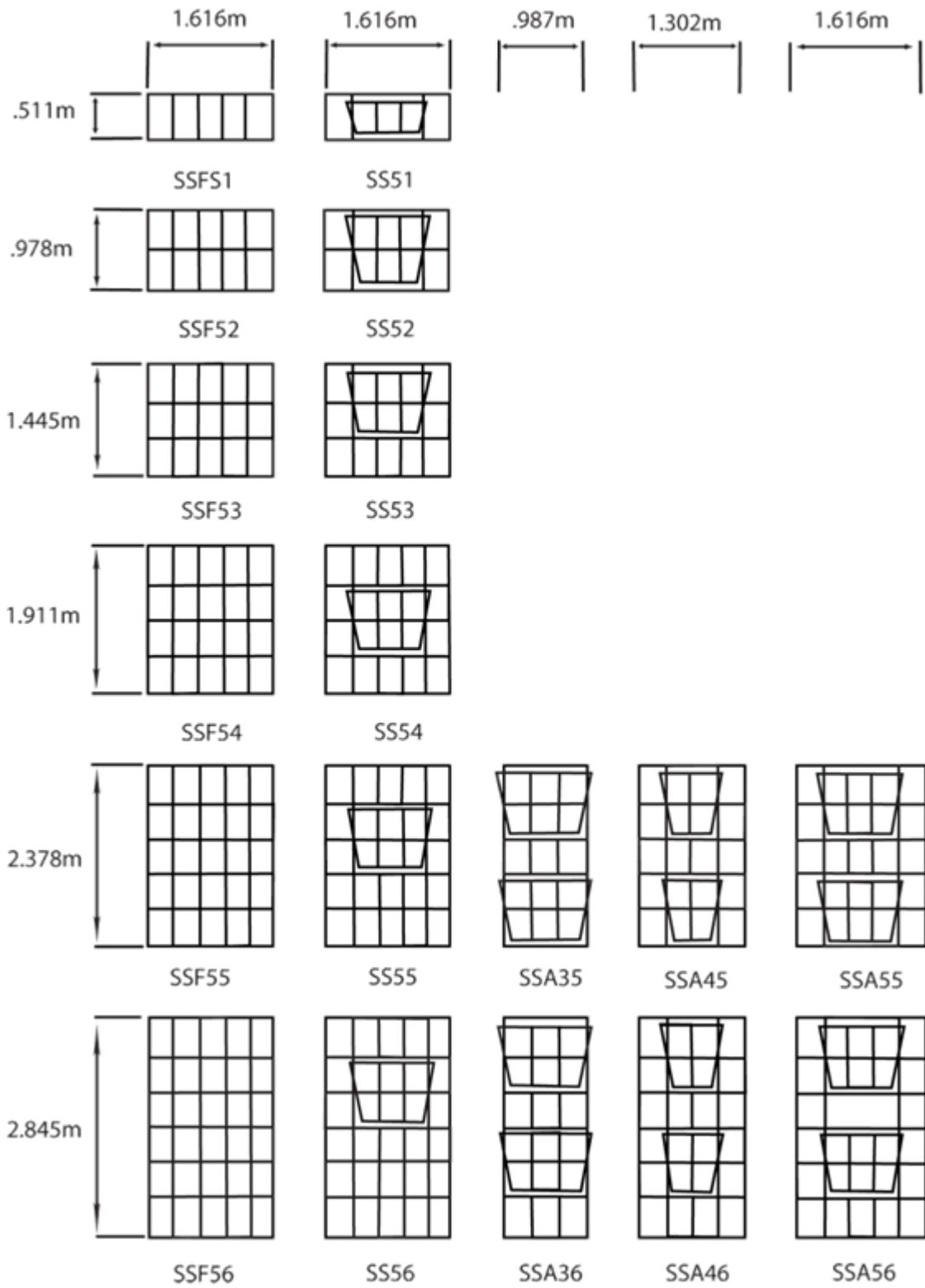

7.8 BURLER BARS TO STEEL WINDOWS

Where windows are fitted with burgler bars, these are to be of standard pattern welded at each intersection, flattened and welded to steel window frame to opening sections only

7.9 GAUZE SCREENS TO WINDOWS

Gauze screens to windows shall be constructed with pressed steel or extruded aluminium frames and filled in with approved fibreglass gauze having 1,5 x1,5 meshes.

The screens to outward opening ventilators shall be attached to the inside of windows with studs or clips in such a way as to be readily removable, and shall have sliding portions for access to window fasteners etc. screens to top hung ventilators may be hinged for access to fasteners.

Frames to screens of inward opening windows shall be of thicker metal than those to outward opening windows or be of rolled mild steel sections and fixed on outside face of windows with screws and nuts or other approved means.

The screens are to be spray painted with enamel of approved colour and baked on or with natural anodised surfaces to aluminium screens.

PC 7 MEASUREMENT AND PAYMENT

Item	Unit
-------------	-------------

PC 7.1 Steel Windows	Number (No)
----------------------------	-------------

The unit of measurement shall be the number of windows for each type installed complete with ironmongery and burgler bars.

The tendered rate for the steel windows shall include full compensation for the supply of all labour and materials, transport of all materials to site, the complete installation of the windows, preparation of the windows for glazing as specified.

Item	Unit
-------------	-------------

PC 7.2 Steel door frames for 230 mm wall	Number (No)
--	-------------

The unit of measurement shall be the number of 1,6mm thick pressed steel door frame for door size 813mm x 2032mm high suitable for 230mm wall.

The tendered rate for the steel door frames shall include full compensation for the supply of all labour and materials, transport of all materials to site, the complete installation of the doors, preparation of the door frames for the doors as specified.

Item	Unit
-------------	-------------

PC 7.3 Steel door frames for 130 mm wall	Number (No)
--	-------------

The unit of measurement shall be the number of 1,6mm thick pressed steel door frame for door size 813mm x 2032mm high suitable for 130mm wall.

The tendered rate for the steel door frames shall include full compensation for the supply of all labour and materials, transport of all materials to site, the complete installation of the doors, preparation of the door frames for the doors as specified.

Item **Unit**

PC 7.4 Steel door frame with steel door for 230 mm wall Number (No)

The unit of measurement shall be the number of 1,6mm thick pressed steel door frame with steel door for door size 813mm x 2032mm high suitable for 230mm wall.

The tendered rate for the steel door frames shall include full compensation for the supply of all labour and materials, transport of all materials to site, the complete installation of the doors, preparation of the door and frames for painting.

Item **Unit**

PC 7.5 Gear operated steel roller shutter door Number (No)

The unit of measurement shall be the number of gear operated roller shutter doors manufactured from 1,22 mm thick metal with 75 mm slats and with dimensions as shown on the drawings and operated by means of bevel gears driven by a vertical shaft operated by means of detachable handle.

The tendered rate for the steel roller shutter door shall include full compensation for the supply of all labour and materials, transport of all materials to site, the complete installation of the doors, curtain, vertical guides and overhead mechanism according to the manufacturers specifications.

Item **Unit**

PC 7.6 Push up type steel roller shutter door Number (No)

The unit of measurement shall be the number of push up type roller shutter doors manufactured from 0,91 mm thick metal with 50 mm slats and with dimensions as shown on the drawings and operated by means of hand.

The tendered rate for the steel roller shutter door shall include full compensation for the supply of all labour and materials, transport of all materials to site, the complete installation of the doors, curtain, vertical guides and overhead mechanism according to the manufacturers specifications.

Item **Unit**

PC 7.7 Purpose made sheep exit sliding door Number (No)

The unit of measurement shall be the number of purpose made doors manufactured as per drawings and specifications, as shown on the drawings and operated by means of hand.

The tendered rate for the purpose made sliding door shall include full compensation for the supply of all labour and materials, transport of all materials to site, the complete installation of the doors, curtain, vertical guides and overhead mechanism according to specifications.

Item

Unit

PC 7.8 Security gates Number (No)

The unit of measurement shall be the number of security gates manufactured as per drawings and specifications, as shown on the drawings and operated by means of hand.

The tendered rate for the purpose made sliding door shall include full compensation for the supply of all labour and materials, transport of all materials to site, the complete installation of the doors, curtain, vertical guides and overhead mechanism according to specifications.

8 SECTION 8: TIMBER ROOF TRUSSES

All timber roof trusses shall comply with the requirements of SANS 2001-CT2 Specification for Construction Works – Structural Timberwork (Roofing).

This part of SANS 2001 covers the construction of timber roof assemblies in buildings. It includes:

- a) the manufacture of bolted trusses that are designed in accordance with the requirements of SANS 10400,
- b) the erection of prefabricated timber trusses,
- c) the erection of rafters and purlin rafters,
- d) the fixing of purlins and battens, and
- e) the fixing of bracing to roofing members to support ceilings that comprise gypsum plasterboard, fibre-cement board or similar boards.

8.1 MATERIALS

8.1.1 PREFABRICATED ROOF TRUSSES:

Pre-fabricated timber roof trusses shall comply with the requirements of SABS Specification 0163 and be constructed of South African pine as described in Clause 8.5 to the designs shown on the Manufacturer's detail drawings. The timber shall be of cross-sectional dimensions shown, cut to correct lengths with ends square or at the required angle. Trusses shall be assembled in truss fabricating jigs with the truss having the proper camber, all tightly clamped together with joints secured using approved connector plates of galvanised steel sheet. Connector plates shall be pressed into the timber simultaneously from both sides of the truss with a hydraulic press capable of exerting such pressure as will ensure complete penetration of the teeth into the timber. The connector plates shall be of such size as will ensure that the joints so made will adequately withstand the forces exerted on the joints.

In coastal areas connector plates in buildings without ceilings shall be painted with two coats of epoxy tar complying with SABS Specification 801 Type 2, or rust neutralising paint.

Approval of pre-fabricated roofing systems, whether measured as an alternative or not, shall be subject to the following requirements:

- (a) The Manufacturer of the pre-fabricated trusses shall hold a certificate of competence issued by the Institute for Timber Construction.
- (b) A polyester print, size A1 having a minimum thickness of 0,5mm, shall be submitted by the Contractor to the Employer's Agent Representative at an early stage for approval by the District Chief Engineer.
- (c) The drawings shall be signed by a Registered Professional Engineer whose name appears on the Departmental panel for structural work.
- (d) In the case of systems buildings, approval shall be given with submission of the contract drawings on acceptance of the tender.

Over and above the supervision undertaken by the Representative/Agent, the Truss Fabricator or his Design Engineer shall inspect the completed roof structure and issue a certificate of confirmation to the Department that:

"The roof structure(s) has (have) been erected in accordance with the Design Engineer's drawings, as accepted by the Department, and the relevant details given in the manual "THE ERECTION AND BRACING OF TIMBER ROOF TRUSSES" issued by the National Timber Research Institute and the Institute for Timber Construction."

Descriptions (prices) of pre-fabricated roof trusses shall be deemed to include design.

8.1.2 SOFTWOOD ROOFING TIMBER:

All timber shall be ordered in the dimensions in which it will be used and shall not be sawn into smaller cross-sectional sizes.

The moisture content of the timber shall not exceed 17 %.

8.1.3 ROOFING POLES:

Roofing poles shall comply with the requirements of either SANS 457-2 (softwood) or SANS 457-3 (hardwood) and shall be of the diameter shown in the construction drawings.

All roofing poles shall be treated in accordance with the requirements of SANS 10005.

8.1.4 BATTENS AND BRANDERING:

Battens and brandering shall comply with the requirements of either SANS 1783-4 or SANS 1707.

8.1.5 CONNECTORS:

Nails:

Nails shall comply with the requirements of SANS 820 and shall have the dimensions as given in tables 1 and 2, as appropriate.

Table 1 – Ordinary Nails

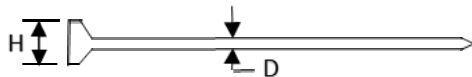

Dimensions in millimetres

1	2	3
Length	<i>D</i>	<i>H</i>
63	3,72 to 3,25	5,9 to 7,0
75	3,05 to 3,65	6,3 to 7,7
90	3,90 to 4,10	7,8 to 9,0
100	3,90 to 5,15	7,8 to 10,7
150	5,45 to 7,25	10,4 to 15,2
175	6,95 to 7,25	13,2 to 15,2
200	6,95 to 7,25	13,2 to 15,2

Table 2 – Clout nails

1	2	3
Length	<i>D</i>	<i>H</i>
32 and greater	2,72 to 2,88	8,2 to 9,1

Nuts, bolts and threaded rods:

Nuts shall comply with the requirements of SANS 1700-14-1, SANS 1700-14-2, SANS 1700-14-3 or SANS 1700-14-4.

Bolts shall comply with the requirements of SANS 1700-7-1, SANS 1700-7-2 or SANS 1700-7-3, and shall have a shank that is 20 mm longer than the total thickness of the timber which is to be bolted together.

Washers:

Washers shall have the dimensions given in table 3.

Table 3 – Washer sizes

Dimensions in millimetres

1	2	3
Bolt diameter	Washer size	
	Square	Round
Up to 8	25 × 25 × 2,4	25 × 2,4
Up to 12	36 × 36 × 6	36 × 3,6
Up to 20	60 × 60 × 6	60 × 6
Exceeding 20	75 × 75 × 6	75 × 6

Nail plates:

Nail plates, toothed connectors, split rings and shear plates shall comply with the requirements of SANS 10243.

Hangers and hurricane clips:

Metal punched plate hangers and hurricane clips shall have a Zinc galvanized coating of 275 g/m², or have an equivalent corrosion resistance, and shall bear a mark which readily identifies the manufacturer or supplier.

Hangers and hurricane clips shall be tested by an accredited testing laboratory to demonstrate that, when bolted or nailed through predrilled or prepunched holes into structural softwood (pine) members, they can transfer, across the joint, a permissible load of not less than the following without slippage occurring:

- a) hurricane clips: 1,2 kN
- b) hangers: 4,0 kN

Masonry anchors:

Metal masonry anchors shall be of the expanding type, be corrosion resistant and have a diameter and length of not less than 10 mm and 45 mm, respectively, and shall be installed in accordance with the manufacturer's instructions.

8.2 DRAWINGS

Drawings of the roof assembly shall be provided by a qualified approved supplier of pre-manufactured roof trusses showing the detail as listed below:

- (a) Details of the roof system with the position of the rafters and purlins indicated thereon as well as typical elevations.
- (b) Bracing as recommended by the Institute for Timber Construction.
- (c) Sizes and grading of the timber components.
- (d) Truss sizes, e.g. height of ridge or angle of pitch.
- (e) Plate sizes for every connection point. (Code numbers only are deemed insufficient.)
- (f) Separate connection details for hip, valley and jack rafters.
- (g) Maximum spacing for purlins and bracing to ceilings shall be according to specifications as set out further in this document.
- (h) The type of roof covering as well as the design load.

8.3 JOINTING OF TIMBER MEMBERS

All joints shall be close-fitting and members shall not have to be forced into position as a result of warp (bow, twist, spring or cup). Trusses shall be assembled in plane, and in such a way as to avoid damage to any of the members.

8.3.1 BOLTED AND NAILED CONNECTIONS:

Nails shall be driven in at right angles to the grain of the timber and to such a depth that the heads are flush with the timber surface. In hardwood, nails shall be driven into predrilled holes that have a diameter of between 0,5 and 0,8 times the nail diameter.

Hurricane clips and hangers shall either be nailed in each hole with 32 mm long wire clout nails, or bolted with a single bolt that has a diameter of 8 mm for hurricane clips or 12 mm for hangers.

Holes drilled through timbers to accommodate bolts shall have a diameter that exceeds the bolt diameter by more than 1 mm. holes shall be drilled at right angles to the joints. Where timber-to-timber connections are to be made, the components shall be clamped together before drilling.

All bolts used to connect structural members shall be installed with washers under both the head and the nut. Nuts shall be tightened so that the washers just bite into the surface of the timber. Bolts shall be of sufficient length so as to allow at least one full thread to project from the nut when tightened.

In pole members, bolts shall not be installed within one pole diameter of a cracked or split end. Nails shall not be placed in cracks in pole members.

Nuts shall be so tightened that the members fit closely. If necessary, nails shall be tightened again after the timber has reached its equilibrium moisture content.

Bolts and nails in members other than poles shall not be located closer to the edge of members than 50 mm for bolts and 40 mm for nails. Bolts and nails shall be located along the centre line of the poles. Nails and bolts shall be spaced at least 20 mm and 50 mm, respectively, away from each other.

8.3.2 NAIL-PLATE CONNECTORS:

Nail-plate connectors shall be pressed into timber using either a mechanical pressing device or a carpenter's hammer, depending upon their design.

When making nail-plated trusses, timber that has defects, such as wane and dead knots in the connector plate contact area, shall not be used unless the size of the connector plate is increased by 25 mm in both length and the breadth of the original nail-plate dimensions to compensate for the nails that have become ineffective at that defect in the timber.

The average gap between any two adjacent members in nail-plated connections shall not exceed 1,5 mm. the difference in thickness between adjacent members shall not exceed 1,0 mm.

Nail-plate connectors shall be evenly embedded to ensure full penetration of all teeth without damage to the timber or fastener.

Nail-plate connectors, when fixed, shall not project beyond the outer edge of the members which they join together. The lower edge of any nail-plate connector located over a point of support to a trussed rafter shall be at least 5 mm away from the lower edge of the member in contact with the support.

8.4 INSTALLATION OF MASONRY ANCHORS

Masonry anchors shall be installed in accordance with the manufacturer's instructions.

8.5 RESHAPING AND RESAWING OF MEMBERS

When treated softwood members are reshaped or resawn, the end grain of the exposed ends shall be painted with a suitable timber preservative.

8.6 INSTALLATION OF ROOF TRUSSES, RAFTERS AND PURLIN BEAMS

Trusses, rafters and purlin beams shall be supported on:

- a) wall plates, in accordance with the requirements of table 4, or similar flat bearing surface which are levelled and positioned so as to ensure that the ends of such members are vertically aligned, or
- b) hangers, twice bolted to walls with masonry anchors.

Where ends are not built into walls or supported by hangers, the ends shall be skew nailed into such bearings on each side by means of two 100 mm long ordinary wire nails. Hangers shall

either be nailed in each hole with 32 mm long clout wire nails or be bolted with a single 12 mm diameter bolt.

Site alterations to trusses or rafters may only be made if such alterations do not compromise their design intent or performance in use (or both).

All rafters and roof trusses shall be tied down to the supporting walls by means of the roof anchorages which are built into the supporting walls or columns. Galvanised steel straps shall be nailed to the roofing members by means of not less than eight clout nails. Galvanised steel wires shall be tied together.

Table 4 – Wall plate sizes

1	2
Truss support span S (m)	Cross section of plate (mm)
$S \leq 10$	38 × 76
$10 < S \leq 15$	38 × 114
$S > 15$	38 × 152

8.6.1 ERECTION OF TRUSSES:

Preparatory work:

Before trusses are erected, the area to receive trusses shall be checked to ensure that the wall plates are level and that the holding-down wires or the hoop-iron strap has been built into the supporting structure at the correct centres.

The positions of the trusses on the wall plates shall be marked in accordance with the drawings and the specified truss centres. Trusses adjacent to a gable shall be positioned between 50 mm and 100 mm from the inside of the gable wall.

Lifting of trusses:

Where possible, trusses shall be handled and lifted in an upright or vertical position. If the trusses are to be moved horizontally, suitable intermediate support shall be provided to prevent lateral distortion of the trusses, which can lead to possible damage.

When trusses are lifted by hand, care shall be taken to prevent excessive lateral bending when sliding them over walls and when tipping them upright on the walls. When using rigging, care shall be taken not to damage the timber and connectors at the pick-up points.

Multiple trusses that comprise identical trusses joined side by side should preferably be assembled on the ground to form a complete unit. Where a multiple truss is too heavy to lift or handle, it may be assembled in situ.

Once trusses have been lifted into position, they shall be checked for any damages that might have occurred during the lifting and handling operations. A damaged truss shall be removed or repaired so that the truss as erected does not compromise its design intent or performance in use.

Temporary bracing:

The first truss shall be lifted into position onto the wall plates and temporarily braced to the ground or wall plate with grade 5 timber that has a minimum size of 78 x 38 mm, or supported against the gable end so that the truss is both straight and vertically plumb. Thereafter, the next few trusses may be lifted into position at their correct spacing and fixed in position with temporary runners and bracing.

The erected trusses shall be lined up, levelled, plumbed and straightened before the installation of the permanent web and rafter bracing. Thereafter, the remainder of the trusses may be erected, ensuring that temporary bracing and runners are fixed as the erection of trusses proceeds.

Permanent bracing:

Upon completion, all trusses shall be checked for straightness, plumbness and that they are level, and shall be adjusted, as necessary, on the wall plate. The remainder of permanent bracing shall be fixed.

8.6.2 INSTALLATION OF BATTENS AND PURLINS:

Battens and purlins shall be continuous over at least three rafters (i.e. two rafter spacings) and shall be fixed to every rafter that they cross. Battens of size 38 mm x 38 mm shall be nailed to the rafters with 75 mm wire nails, and battens of size 38 mm x 50 mm shall be set on edge with 90 mm wire nails. Purlins shall be fixed to rafters with hurricane clips. Care shall be taken not to split any of the members during the nailing process.

The ends of battens and purlins shall be sawn square and butt-jointed centrally over the rafter member so as to provide suitable bearing and fixing. Joints in battens shall be arranged so that not more than one batten in any three is joined on any one rafter.

Purlins shall be spliced such that the splices shall be located in close proximity to rafters and shall be staggered so that there is not more than one splice in three consecutive purlins. Purlins and rafter splices shall not be located within 1,5 m from the gable ends.

8.7 CEILING ASSEMBLY

Branding of size 38 mm x 38 mm required to support gypsum plasterboard, fibre-cement board or similar board shall be securely spiked to the supporting timbers with 75 mm wire nails at centres that do not exceed 450 mm. cross branding shall be cut in between the longitudinal branding and skew nailed to the same, using 75 mm wire nails at centres that do not exceed 900 mm.

PC 8 MEASUREMENT AND PAYMENT

Item	Unit
PC 8.1 Prefabricated roof trusses	Sum

The unit of measurement shall be the Sum for the complete supply and erection of all roof trusses purlins and branding.

The tendered rate for the prefabricated roof trusses shall include full compensation for the design, manufacturing, supply and delivery to site erection of roof trusses, purlins and branding to specifications, including of all labour and materials, transport of all materials to site, the complete erection of the roof, preparation of the roof to receive the roof covering, ceiling and soffits as specified and the issuing of a certificate of compliance.

9 SECTION 9: CEILINGS AND TRAPDOORS

9.1 BRANDERING TO CEILINGS:

Branding not exceeding 65 mm in width shall be of South African softwood complying with the requirements of SABS Specification 653. Branding exceeding 65 mm in width shall be in accordance with SABS Specification 563. All branding shall bear the standardisation mark of the South African Bureau of Standards.

The branding shall be securely spiked up to the supporting timbers with 90 mm wire nails. Cross branding shall be cut in between the longitudinal branding, all securely skew nailed to same with 90 mm wire nails. The sizes and spacing of branding for the various types of ceilings shall be as follows:

9.1.1 GYPSUM PLASTER BOARD:

Size 38 x 38 mm, fixed parallel to the ceiling boards at centres not exceeding 450 mm for 900 mm wide boards and 600 mm for 1200 mm wide boards. In the other direction branding shall be spaced at 450 mm centres for both 900 and 1 200 mm wide boards. Branding shall also be fixed around edges of ceilings where required for fixing cornices.

Size 38 x 38 mm, at not exceeding 450 mm centres in one direction at right angles to the supporting timbers where metal H-section jointing strips are to be used.

9.1.2 GYPSUM PLASTER BOARD WITH PLASTER FINISH:

Size 38 x 38 mm, at not exceeding 400 mm centres in one direction at right angles to the supporting timbers, and around edges of ceiling where required for fixing cornices.

9.1.3 FIBRE BOARD

Size 38 x 50 mm, at all joints between ceiling boards where joints between the boards are close butted or do not exceed 6 mm wide or size 38 x 76 mm where joints between the boards exceed 6 mm wide and elsewhere size 38 x 38 mm, fixed parallel to the ceiling boards at not exceeding 450 mm centres for 900 mm wide boards or 400 mm centres for 1 200 mm wide boards. Branding in other direction shall be spaced at 900 mm centres for both 900 and 1 200 mm wide boards. Branding shall also be provided around edges of ceilings where required for fixing cornices.

9.2 COVERING TO CEILINGS:

9.2.1 GYPSUM PLASTER BOARD:

Gypsum plaster board shall be 6,4 mm thick gypsum board complying with the requirements of SABS Specification 266.

The boards shall be nailed to the branding with 2 mm diameter galvanised or cadmium plated clout headed nails, 40 mm long, spaced at not more than 100 mm centres at edges of boards and 150 mm centres along the intermediate branding.

Cover strips to joints in gypsum plaster board ceilings shall be of plaster board as for ceilings, 50 mm wide, with smooth machined edges, neatly jointed and fixed with 2 mm diameter galvanised or cadmium plated clout headed nails, 40 mm long, spaced at not more than 150 mm centres.

Where brandering has been installed at right angles to ceiling boards metal H-section jointing strips shall be the acceptable means of distinguishing joints between boards.

The ceiling boards shall be in 900 or 1 200 mm widths layed out and with fixing commencing at the centre line of the ceiling. Ceiling boards shall only be cut down the length to form infill panels against walls, where such panels shall not be less than 300 mm wide and shall be in single lengths to the width of ceilings wherever possible.

9.2.1 GYPSUM PLASTER BOARD WITH PLASTER FINISH:

Gypsum plaster board ceilings with flush plaster finish shall be of gypsum plaster board as described in Subclause 9.5.1, but nails shall be spaced at not more than 100 mm centres along the lines of the brandering.

Joints between boards shall be covered with wire or self-adhesive strips of brown paper scrim tape, all in accordance with the Manufacturer's instructions.

9.2.3 FIBRE CELLULOSE BOARD:

Fibre cellulose board for ceilings shall be 6 mm thick insulation board complying with the requirements of SABS Specification 803 and of flat unpressed type.

The boards shall be nailed to the brandering with 2 mm diameter galvanised or cadmium plated clout headed nails, 40 mm long, spaced at not more than 100 mm centres at edges of boards and 150 mm centres along the intermediate brandering.

The joints between the boards shall be covered with 25 mm plastic cover beads pushed in at each side of the boards.

9.3 CORNICES TO CEILINGS:

Gypsum plaster board:

Gypsum plaster board cove cornices to ceilings shall comply with the requirements of SABS Specification 622 and shall be of 76 mm girth as specified, all nailed through the ceiling boards to the brandering and to walls at not exceeding 300 mm centres with 2 mm diameter galvanised or cadmium plated clout headed nails, 40 mm long, or fixed to walls with hardened steel nails driven into the brickwork with heads flush with surface.

Cornices shall be scribed at internal angles, mitred at external angles and shall be in long lengths with splayed heading joints where necessary.

Fixing of cornices by means of an approved adhesive is acceptable, but this method of fixing shall be carried out in strict accordance with the Manufacturer's instructions.

9.4 TRAPDOORS IN CEILINGS:

Openings for trap doors in ceilings shall be trimmed with 38 × 100 mm timbers, all securely spiked to the supporting timber trusses. The framework for the trap door shall be formed out of 38 × 50 mm softwood, properly spiked to supporting timbers and trimmers. The size of the opening shall be 650 × 650 mm.

Trap doors shall be formed with skeleton frame of brandering as for ceilings, covered on underside with ceiling boards and hung on a pair of 75 mm steel butts. Soffits of trap doors shall be flush with soffit of ceiling when closed and flap back 180° on to top of the brandering when opened closed trap doors shall rest on 50 × 19 mm softwood fillets all around opening, mitred at angles and securely fixed to soffit of ceiling.

Any trap door larger than 650 × 650 mm shall be provided with brandering along the centre, securely spiked to the skeleton frame.

9.5 CEILING INSULATION:

All ceiling insulation materials shall comply with SABS Specification 1381.

Ceilings shall be insulated with approved resin bonded glass fibre or rock mineral wool insulation, not less than 75 mm thick in blanket form manufactured for the insulation of ceilings and laid in single thickness. The insulation shall be cut to size to closely fit between walls, ceiling joints, rafters, etc. and laid over brandering.

PC 9 MEASUREMENT AND PAYMENT

Item	Unit
PC 9.1 Ceiling board.....	Square metre (m ²)

The unit of measurement shall be the square metre ceiling board supplied and installed.

The tendered rate for the ceiling board shall include full compensation for the supply and delivery to site, cut to size and installation of ceilings, including of all labour and materials, transport of all materials to site, the complete installation of the ceiling, preparation of the ceiling to receive the ceiling insulation as specified as well as the cornice to the ceiling.

Item	Unit
PC 9.2 Gypsum cornice to ceiling.....	metre (m)

The unit of measurement shall be the metre length of gypsum cornice supplied and installed.

The tendered rate for the gypsum cornice shall include full compensation for the supply and delivery to site, cut to size and installation of cornice, including of all labour and materials, transport of all materials to site, the complete installation of the cornice, making good of the cornice to the ceiling.

Item	Unit
PC 9.3 Glass fibre ceiling insulation.....	Square metre (m ²)

The unit of measurement shall be the square metre of glass fibre ceiling insulation supplied and installed.

The tendered rate for the glass fibre ceiling insulation shall include full compensation for the supply and delivery to site, cut to size and installation of insulation material, including of all labour and materials, transport of all materials to site, the complete installation of the insulation and the making good thereof.

10 SECTION 10: STEEL AND POLYCARBONATE ROOF AND SIDE COVERINGS

10.1 GENERAL

Profiled metal sheet roof coverings shall comply with the following minimum requirements:

- a) Galvanised metal roof sheets shall have a minimum thickness of 0,8mm for roofs of 4° - 14° pitch inclusive and 0,6mm for roof pitches of 15° and upwards.
- b) Polycarbonate roof sheets shall be of a high quality with a co-extruded layer of UV stabilised polymer on both sides to create a weather resistant surface UV2. The roof sheets shall comply to standards UL94 (Class V-3), BS476 – Part 7 (Class 1Y), ASTM D1929 (Pass minimum of 450 °C), comply with ISO 3795.
- c) Roof trusses shall be spaced at not exceeding 1,2 m centres, except where the pitch is 12° or less, when the spacing may not exceed 1 m centres.
- d) Purlins shall be spaced at not exceeding 1,0 m centres for roof pitches of 4° to 30° inclusive and at 1,2 m maximum for roofs having pitches of 31° and greater.
- e) Unless otherwise specified in this section, profiled metal roofing sheets shall be used and fixed all in accordance with SABS Code of Practice 0237.
- f) Roof sheets shall have galvanised coating of Z150 quality for inland areas and Z275 quality for coastal areas.
- g) Chromadek roof sheets shall have galvanized coating of Z275 quality.
- h) All necessary cutting of sheets shall be properly performed. Cut edges at sides of valleys and where otherwise exposed shall be perfectly straight.
- i) Drive screws will be permitted.
- j) The Contractor is to submit a certificate, signed by the Merchant, stating that the galvanised roof covering supplied complies with the required thickness specified.
- k) Roof sheets shall be single lengths to each slope of the roof.

10.2 PROFILES

10.2.1 STEEL CORRUGATED SHEETS

Corrugated galvanised iron roofing sheets shall comply with SABS Specification 934 with corrugations 17,5 mm deep at 76 mm centres giving an effective width of approximately 610 or 762 mm between the crests of the outermost corrugations respectively, all coated with zinc having a mass of not less than that indicated in the following table for the three classes of galvanising specified:

g/m ² of surface area	
Average	Individual (Minimum)
600	510
450	385
275	235

At exposed verges of roofs the iron shall be finished with neatly formed rolls. The sheets shall have side laps of not less than one and a half corrugations. The minimum end laps for the different roof slopes shall be in accordance with the following table:

Slope of roof	End lap (mm)
Greater	150
30°	175
25°	200
20°	225
Smaller	300

10.2.2 STEEL RIB BOX (IBR) SHEETS

- a) Box Rib (IBR) roofing sheets shall be used with ribs of 36mm deep and 172mm pitches.
- b) All roof sheets shall be hot dip galvanised in accordance with SANS 3575/SANS 14713, coating grade Z275 quality for coastal areas and Z150 quality for inland areas.

10.2.3 POLYCARBONATE RIB BOX (IBR) SHEETS

- a) Polycarbonate Box Rib (IBR) roofing sheets shall be used with ribs of 36mm deep and 172mm pitches and sheet thickness of 1,2 mm.
- b) The roof sheets shall comply to standards UL94 (Class V-3), BS476 – Part 7 (Class 1Y), ASTM D1929 (Pass minimum of 450 °C), safety compliance with ISO 3795

10.2.4 CHROMADEK STEEL RIB BOX (IBR) SHEETS

- c) Chromadek Box Rib (IBR) roofing sheets shall be used with ribs of 36mm deep and 172mm pitches.
- d) All roof sheets shall be hot dip galvanised in accordance with SANS 3575/SANS 14713, coating grade Z200. Colour coated to choice on the one side and standard backing coat on the other side.

10.3 INSULATION

Prior to the laying of roof sheets, the roof structure shall be covered with an approved insulation underlay having a non-combustible reflective foil finish on upper surface and a layer of plastic on the underside all bonded to a substrate of kraft paper having synthetic reinforcing, all as described in SABS Specification 1381.

The insulation underlay shall be laid longitudinally and pulled taut over the top edges of the rafters and then nailed thereto with galvanised clout nails. Working from the eaves level upwards, a minimum overlap of 150 mm shall be allowed to ensure complete protection.

Roofs shall be left perfect, clean and watertight on completion and all eaves and valley gutters shall be cleaned out.

Valleys shall be of open or closed construction as follows:

- (a) Open valleys: a strip of underlay approximately 1 m wide shall be laid along the whole length of the valley and nailed into position with clout nails close to the edges of the valley boards farthest from the centre line of the valley. Provide metal valley lining as described in Clause 10.6, ensuring that it extends at least 50 mm beyond the edges of the tiling, all securely fixed along both edges. Matching roof tiles/slates shall be neatly cut to the line of the valley and laid to project over the edges of the valley lining by at least 50 mm. A gap of at least 50 mm shall be provided down the centre line of the valley between the edges of the tiles.
- (c) Closed valleys: all constructed as for open valleys except that the shets are to be cut in such a manner that when laid they form a butt joint closing valley.

10.4 RIDGING (METAL)

10.4.1 FOR CORRUGATED ROOFING;

Galvanised iron ridging for ridges and hips of corrugated iron covered roofs shall be 0,60 mm thick (after galvanising), coated with zinc of mass as specified for roofing iron in the table in Subclause 7.6.2 (a).

The ridging shall be 450 mm girth with roll top and bent down edges, lapped 225 mm at heading joints; cut, properly lapped and fitted at intersections of ridges, hips and valleys; and beaten into corrugations of roofing iron to close openings. Roll shall be closed at feet of hips and at gable ends.

Ridging shall be fixed with screws to wood purlins and hook bolts to steel purlins using washers under heads and nuts, all as described for fixing corrugated iron roofing, but spaced at not exceeding 300 mm centres.

10.4.2 FOR RIB-TROUGH ROOFING

Galvanised iron ridging for ridges of IBR roof shall be 0,60mm thick (after galvanising), coated with zinc of grade Z275.

The ridging shall be 450mm girth with roll top and bent down to edges, lapped 225mm at the heading joints, cut, properly lapped and fitted at intersections of ridge and provided with serated closers.

Ridging shall be fixed with hook bolts to steel purlins using washers under heads and nuts and spaced at not eceeding 300mm centres.

10.5 FLAT METAL ROOFS

A flat metal roof is defined as a flat structure covered with profiled metal roofing sheets laid with a fall of between 0° and 4° maximum. The use of such roofs is restricted to relatively small outbuildings/roof areas where no other solution proves viable or possible.

The supporting structure shall be such that any permissible deflection of the covering and/or roof under sustained load of snow or hail in susceptible areas and of heavy rain will not cause the roof to leak.

The profiled steel sheets shall be of an approved type in single lengths preferably using concealed fixing. Where conventional fixing screws are used, these are to be rendered permanently watertight by means of a profiled cover strip held securely in place with the Manufacturer's fixing clips.

Side laps of profiled sheets are to be sealed by permanently welting with a machine. Purlins are to be spaced at 1,0 m centres maximum.

10.6 LININGS TO VALLEYS

Linings to valleys in roofs shall be of galvanised sheet iron or sheet copper as specified having 225 mm laps at end joints and dressed up and on to purlins at each side of valleys in IBR and Corrugated iron roofs. Linings shall be cut and properly fitted at top and bottom of valleys.

10.7 FLASHINGS

Flashings, where butting against vertical wall or other surfaces, shall be of galvanised steel iron, turned up for at least 100 mm against vertical surfaces and close dressed for not less than 200 mm on top of the roofing iron.

10.8 MAKING GOOD

Roofs, gutters, flashings, etc. shall be carefully examined at completion of the work, any holes or other defects soldered up or otherwise made good and the whole left perfect and watertight.

10.9 ROOF TRIMMINGS

Fascias and barge boards, where prescribed, shall be of pressed fibre cement boards, of section described and in long lengths, butt jointed with 75 mm wide galvanised steel plates four times bolted with galvanised bolts over joints or with standard aluminium jointing strips and bolts

PC 10 MEASUREMENT AND PAYMENT

Item	Unit
PC 10.1 Roof covering with 0,58mm thick galvanised IBR roofing sheets fixed to timber purlins	Square metre (m ²)

The unit of measurement shall be the square metre of 0,55mm thick galvanised IBR roof sheeting, fixed to timber purlins with approved screws in accordance with the manufacturer's instructions.

The tendered rate for the roof covering shall include full compensation for the supply of all labour and materials, transport of all materials to site, the complete erection of the roof sheets in accordance with the manufacturer's instructions and the making good thereof.

Item**Unit**

PC 10.2 Roof covering with 0,58mm thick Chromadek galvanised IBR roofing sheets Class Z275 fixed to timber purlins Square metre (m²)

The unit of measurement shall be the square metre of 0,58mm thick Chromadek galvanised IBR roof sheeting Class Z275, fixed to timber purlins with approved screws in accordance with the manufacturer's instructions.

The tendered rate for the roof covering shall include full compensation for the supply of all labour and materials, transport of all materials to site, the complete erection of the roof sheets in accordance with the manufacturer's instructions and the making good thereof.

Item**Unit**

PC 10.3 Roof covering with Polycarbonate IBR roofing sheets Square metre (m²)

The unit of measurement shall be the square metre of clear 1,2 mm thick polycarbonate IBR roof sheeting fixed to timber purlins with approved screws in accordance with the manufacturer's instructions.

The tendered rate for the roof covering shall include full compensation for the supply of all labour and materials, transport of all materials to site, the complete erection of the roof sheets in accordance with the manufacturer's instructions and the making good thereof.

Item**Unit**

PC 10.4 Ridge capping 450mm girth with minimum 225mm laps metre (m)

The unit of measurement shall be the metre of 0,6mm thick galvanised Ridge Capping, 450mm girth with roll top and bent down to edges, lapped 225mm at the heading joints, cut, properly lapped and fitted at intersections of ridge and provided with serated closers. Ridging shall be fixed with hook bolts to steel purlins using washers under heads and nuts and spaced at not eceeding 300mm centres

The tendered rate for the ridge capping shall include full compensation for the supply of all labour and materials, transport of all materials to site, the complete erection of the ridge capping in accordance with the manufacturer's instructions and the making good thereof.

Item**Unit**

PC 10.5 Sisolation insulation on the underside of roof sheets Square metre (m²)

The unit of measurement shall be the square metre of Sisolation insulation on the underside of the roof sheets fixed to the top of the timber purlins all in accordance with the manufacturer's recommendations.

The tendered rate for the insulation panels shall include full compensation for the supply of all labour and materials, transport of all materials to site, the complete erection of the insulation panels in accordance with the manufacturer's instructions and the making good thereof.

Item**Unit**

PC 10.6 Fascias and barge boards metre (m)

The unit of measurement shall be the metre length of pressed fibre cement fascia boards and barge boards fitted on the outside of the roof for trimming all in accordance with the manufacturer's recommendations.

The tendered rate for the fascia boards and barge boards shall include full compensation for the supply of all labour and materials, transport of all materials to site, the complete erection of the fascia- and barge boards in accordance with the manufacturer's instructions and the making good thereof.

11 SECTION 11: JOINERY

11.1 GENERAL

All joinery work shall be put in hand immediately the order has been given to commence work; or after receipt of details, where such are to be supplied, and shall be wedged or glued up until just before fixing in the building. Timber stored on the site shall be properly stacked on delivery and adequately protected against extreme weather and exposure to the sun, until required for use.

a) Hardwood:

Hardwood for joinery shall comply with the requirements of SABS Specification 1099, and shall be of Clear Grade and free of sapwood.

b) Softwood:

Softwood for joinery shall comply with the requirements of SABS Specification 1359 and shall be of Clear Grade.

11.2 JOINERY

All exposed softwood timber in joinery which is not to be painted shall be free from large, loose or dead knots, knot holes, checks, splints, wane or other defects, and in joinery which is to be painted shall be free from all defects other than those which can be filled or otherwise made good in such a way as will not impair the paint finish. All exposed hardwood joinery timber shall be free from all knots, knot holes, checks, splints or other defects.

Purpose made joinery shall be manufactured strictly in accordance with detail drawings where these are provided.

Stock joinery shall be of the best quality.

Joinery shall not be primed until it has been inspected and approved.

Skirtings shall be in long lengths, close fitted, mitred or scribed at angles and securely fixed with hardened nails driven into the brickwork at not more than 700 mm apart.

11.3 WOODEN DOORS

All doors shall be framed and ledged batten wooden doors for use as yard doors where it will be exposed to the elements and have a paint finish and shall comply with the requirements of SABS Specification 1099, shall be of Clear Grade Hardwood 44mm thick and free of sapwood and bear the "MARK".

The Contractor shall provide the Employer's Agent Representative with the full constructional detail of the doors that he proposes to use for approval.
Doors shall be hung on pressed steel door frames.

11.4 HANGING OF DOORS

All doors are to be hung in such a way that the completed door functions smoothly and perfectly.

The clearance gap between door and frame after hanging shall not exceed 2mm (+0mm – 1mm) at sides and head of door. The gap between meeting stiles of doors hung folding shall also comply with the foregoing.

The clearance gap between foot of door and floor may be increased to 6mm (+0mm – 3mm) to accommodate any minor unevenness in the floor surface.

Any door frame found to be distorted or out of plumb shall be reported to the Employer’s Agent Representative before any door is hung to such a frame.

When hung, no strain upon the hinges shall be detectable due to hinge binding. Depending upon the hinges supplied with pressed steel door frames the hanging edge of door may be angled back slightly from the hinge face of door to obviate such binding.

Any door that is too wide or tall to fit the door frame shall be reduced in size by removing material equally from each edge – removing material from one edge only to obtain a fit is unacceptable.

Mortice locks are to be snugly fitted into the mortice with face plate flush with edge of door.

Lever handle door furniture is to be fixed with the backplate parallel to the edge of the door. Ensure that the handles of wever type function smoothly and do not bind.

Screws used for fixing of hinges shall be screwed into holes of suitable sizes.

In addition, prior to the final hanging of any unprotected external door, where such door opens to the outside of the building, both top and bottom concealed edges shall be sealed with not less than two coats of the finish specified for the exposed surfaces of the door. Where the door opens to the inside of the building only the bottom edge of the door shall be so finished.

11.5 PAINTING OF DOORS

All doors shall be painted with one coat oil based wood primer and two coats Polyurethane Enamel paint.

PC 11 MEASUREMENT AND PAYMENT

Item	Unit
PC 11.1 Semi-solid flush internal quality doors	Number (No)

The unit of measurement shall be the number of semi-solid flush internal quality doors hung to steel frames size 40mm thick x 813 x 2032mm high.

The tendered rate for the semi-solid internal doors shall include full compensation for the supply of all labour and materials, transport of all materials to site, the complete hung of the doors in accordance with the manufacturer’s instructions and the making good thereof.

Item		Unit
PC 11.2	Solid flush external quality doors	Number (No)

The unit of measurement shall be the number of Solid flush external quality doors hung to steel frames 40mm thick x 813 x 2032mm high.

The tendered rate for the solid flush external quality doors shall include full compensation for the supply of all labour and materials, transport of all materials to site, the complete hung of the doors in accordance with the manufacturer's instructions and the making good thereof.

Item		Unit
PC 11.3	19 x 75mm Hardwood skirting nailed to walls	metre (m)

The unit of measurement shall be the metre of 19 x 75mm Hardwood skirting nailed to the walls.

The tendered rate for the 19 x 75mm Hardwood skirting shall include full compensation for the supply of all labour and materials, transport of all materials to site, the complete installation of the skirtings and the making good thereof.

12 SECTION 12: IRONMONGERY

12.1 IRONMONGERY

All ironmongery shall be of the best quality and shall be approved prior to fixing.
Articles shall be fixed with matching screws.
No keys shall pass a second lock unless master keyed.
Mortice locks shall be DORMA ST 9600 Series II heavy-duty mortice locks or similar.
Door levers shall be DORMA Coastal Series 5300-30 Nosa door levers or similar.

12.2 FIXING

Ironmongery is to be taken as fixed to wood unless otherwise described.
Items described as “plugged” shall be deemed to include screwing to fibre, plastic or metal plugs.
All necessary preparation of pressed steel door frames for the fixing of ironmongery to the frames has been included with the pressed steel door frames.
All screws, nails, bolts, etc. required for completion of the work shall be supplied by the Contractor.

PC 12 MEASUREMENT AND PAYMENT

Item	Unit
PC 12.1 Three lever heavy-duty mortice lock.....	Number (No)

The unit of measurement shall be the number of three lever heavy duty mortice locks installed.

The tendered rate for the heavy-duty mortice locks shall include full compensation for the supply of all labour and materials, transport of all materials to site, the complete installation of the mortice locks in accordance with the manufacturer’s instructions and the making good thereof.

13 SECTION 13: FLOOR AND WALL TILING

13.1 GENERAL

The floors and skirtings shall be protected from damage during the progress of any remaining work and at completion shall be cleaned and handed over in a perfect condition. The work shall be carried out by skilled workmen experienced in laying these type of floor finishes.

13.2 TILE CEMENT

All tile cement shall be of an approved mixture for ceramic tiles.

13.3 CERAMIC TILES

Finish floors and walls as shown on the drawings with Grade 1 acid resisting ceramic tiles, 8mm thick and of Load Group 4, but of sizes available in the market and of approved colour, all bedded to a true and even surface in ceramic tile cement mortar and with joints not exceeding 8mm wide. After the tiles have been allowed to set for a period of not less than 24 hours, the joints shall be grouted in with an approved epoxy compound.

Form ceramic tile skirtings, 100mm high, covered at junction with floor and rounded on top edge with aluminium strip.

13.4 GLAZED WALL TILING

Glazed tiles for wall tiling shall comply with the requirements of SABS Specification 22.

The tiles shall be fixed in accordance with SABS Code of Practice 0107 with horizontal and vertical joints continuous, and shall have all joints rubbed in solid with neat white cement grout. Tiles shall be well soaked in water before fixing with cement mortar and thoroughly cleaned off after fixing. Walls shall be well wetted before tiling is commenced.

Tiling shall be returned into reveals of openings and on to window sills, and shall be butted at internal angles and provided with mitred joints to external angles. All necessary cutting to tiles shall be properly performed.

PC 13 MEASUREMENT AND PAYMENT

Item	Unit
PC 13.1 8mm Thick ceramic floor tiles to concrete floor	Square metre (m ²)

The unit of measurement shall be the square metre of 8mm thick ceramic floor tiles fixed with approved tile adhesive mixed with bonding liquid in lieu of water and joints grouted with tile grout with 5mm joints continuous in both directions to floors.

The tendered rate for the ceramic floor tiles shall include full compensation for the supply of all labour and materials, transport of all materials to site, cutting of tiles, mixing of adhesive and the complete tiling of the office area in accordance with the manufacturer's instructions and the making good thereof.

Item	Unit
PC 13.2 100mm Wide ceramic tile skirting	metre (m)

The unit of measurement shall be the metre of 8mm thick by 100mm wide ceramic tile skirting fixed with approved tile adhesive mixed with bonding liquid in lieu of water and joints grouted with tile grout with 5mm joints continuous in both directions to plastered walls and rounded off with aluminium rounded strip.

The tendered rate for the ceramic tile skirting shall include full compensation for the supply of all labour and materials, transport of all materials to site, cutting of tiles, mixing of adhesive and the complete tiling of the skirting in accordance with the manufacturer's instructions and the making good thereof.

Item	Unit
PC 13.3 8mm Thick ceramic wall tiles to plastered walls	Square metre (m ²)

The unit of measurement shall be the square metre of 8mm thick ceramic wall tiles fixed with approved tile adhesive mixed with bonding liquid in lieu of water and joints grouted with tile grout with 5mm joints continuous in both directions to plastered walls.

The tendered rate for the ceramic wall tiles shall include full compensation for the supply of all labour and materials, transport of all materials to site, cutting of tiles, mixing of adhesive and the complete tiling of the wall tiled areas in accordance with the manufacturer's instructions and the making good thereof.

14 SECTION 14: INSTALLATION OF GLAZING IN WINDOWS

14.1 MATERIALS

14.1.1 GLASS

Glass in panes not exceeding 0,65m² of surface area shall be clear float glass of "GG" quality (Glazing quality) and of 3mm thickness.

Glass in panes exceeding 0,65m² and up to 1,5m² of surface area shall be clear float glass of "GG" quality (Glazing quality), but of 4mm thickness.

14.1.2 GENERAL PURPOSE PUTTY

Putty shall comply with the requirements of SANS 680

14.1.3 SETTING BLOCKS

Setting blocks shall be rot-proof, non-absorbent and capable of maintaining the requisite edge clearance without presenting local areas of stress to the glass.

14.2 PREPARATION

Before commencing glazing operations, it shall be confirmed that:

- a) the fixing of the frame has been completed,
- b) protective coatings or tapes have been removed from the frame,
- c) rebates are free from obstructions and debris,
- d) all surfaces which are to come into contact with the bedding material have been primed or sealed.

The surfaces, which will come into contact with glazing materials, shall be cleaned and dried.

All metal frames shall, before glazing, be painted with an anti-corrosive primer.

Where pane areas exceed 0,3m², the glass shall be placed on one or two setting blocks along the bottom edge. Setting blocks shall be between 25mm and 75mm long, except at the bottom bar of vertically pivoted windows where a single block of length at least 150mm is sufficient.

Glass sheets shall be checked for edge clearances which shall be not less than

- a) 3mm for glass of length or width up to 2m, and
- b) 5mm for glass of length or width over 2m.

Distance pieces shall be placed on opposite sides of the sheet at centres that do not exceed 300mm, within 50mm of corners and at bead fixing points.

14.3 GLAZING WITH PUTTY

Sufficient bedding putty shall be applied to the rebate to ensure that when the glazing material is pressed into position, the putty is squeezed out around the entire perimeter of the glazing rebate.

The glass shall be positioned that an even bearing is obtained and edge clearances are equal all the way round the pane. The pane shall thereafter be pressed and bedded into the bedding putty until it is at least 3mm from the back of the surface of the rebate.

The front putty shall thereafter be applied and finished off to a splayed finish. The back putty shall be trimmed and finished off to a smooth finish.

Upon completion the putty shall be brushed lightly with a small brush to seal the edges against the glass and the surround.

14.4 MIRRORS

Mirrors shall comply with the requirements of SABS Specification 1236, Class A. unframed mirrors shall have polished edges.

PC 14 MEASUREMENT AND PAYMENT

Item	Unit
PC 14.1 3mm Clear glass to steel window frames	Square metre (m ²)

The unit of measurement shall be the square metre of 3mm thick clear glass to window panes exceeding 0,1m² and not exceeding 0,5m².

The tendered rate for the clear glass shall include full compensation for the supply of all labour and materials (including glass, putty, sprigs, pegs or clips), transport of all materials to site, cutting of glass, preparing of putty and the glazing of all window panes in accordance with the specifications and the making good thereof.

Item	Unit
PC 14.2 4mm Clear glass to steel window frames	Square metre (m ²)

The unit of measurement shall be the square metre of 4mm thick clear glass to window panes exceeding 0,5m² and not exceeding 1,5m².

The tendered rate for the clear glass shall include full compensation for the supply of all labour and materials (including glass, putty, sprigs, pegs or clips), transport of all materials to site, cutting of glass, preparing of putty and the glazing of all window panes in accordance with the specifications and the making good thereof.

15 SECTION 15: PLUMBING AND DRAINAGE

15.1 GENERAL

15.1.1 REGISTERED PLUMBERS AND DRAINLAYERS

Only registered plumbers and drainlayers shall be employed on any plumbing and drainage work.

15.1.2 EARTHWORKS

All Earth Works for pipelines and drainage shall comply with the specifications as set out in Section 1: Earth Works and also to SANS 2001-DP1 Construction Works. Part DP1: Earth Works for buried pipelines and prefabricated culverts.

Payment for Earth Works will be as set out in the relevant Measurement and Payment Clause for this section.

15.1.3 REINSTATEMENT OF INFRASTRUCTURE

In all cases where existing infrastructure has been removed or damaged during the excavations or laying of pipelines, shall be reinstated to its original condition and to the satisfaction of the Employer's Agent Representative.

15.1.4 RAINWATER DISPOSAL AND PROTECTION AGAINST LIGHTNING

In all cases where existing infrastructure has been removed or damaged during the excavations or laying of pipelines, shall be reinstated to its original condition and to the satisfaction of the Employer's Agent Representative.

15.1.4.1 EAVES GUTTERS (UPVC)

UPVC eaves gutters shall be 125mm x 75mm white UV resistant PVC gutters according to SANS Specifications 967.

Gutters shall be laid to proper falls and be provided with angles, stopped ends and outlet nozzles as required.

Gutters shall be fixed on UPVC brackets and each twice screwed to steel purlin.

Brackets shall be spaced at not exceeding 1m centres.

15.1.4.2 RAIN-WATER PIPES (UPVC)

Rain-water pipes shall be 75 x 75mm UPVC downpipes. Pipes shall be provided with offsets, elbows and shoes as required.

The pipes shall be fixed 25mm clear of finished wall face on holderbats to walls, spaced at not exceeding 1,5m apart.

15.1.4.3 EAVES GUTTERS (METAL)

Sheet iron gutters shall be of galvanised sheet iron of thickness specified in the table hereunder, have beaded edges and with all joints riveted and soldered or bedded with an approved epoxy sealant.

Gutters shall be laid to proper falls and be provided with angles, stopped ends and outlet nozzles as required. Angles shall be strengthened with 50 mm wide strips of 0,60 mm thick galvanised sheet iron soldered over the internal mitres inside the gutters.

Gutters shall be fixed on galvanised mild steel brackets of size specified in the table hereunder, bent to shape of gutters with front end taken up to underside of beaded edge of gutter and each twice screwed to roof timbers. Gutters shall be bolted to brackets at front with and including 6 mm diameter galvanised gutter bolts, one to each bracket, positioned close to underside of beaded edge of gutter.

Brackets shall be spaced at not exceeding 1 m centres.

The thickness of sheet iron and size of metal from which brackets are made for the various sizes of gutters shall be in accordance with the following table:

Gutter shape	Gutter size not Exceeding (mm)	Sheet thickness (mm)	Size of metal brackets (mm)
Half round	150	0,60	32 x 3,5
Square	125 x 125	0,60	32 x 3,5
Square	175 x 175	0,80	40 x 5
Square	225 x 225	1,00	40 x 6
Rectangular	Width 150 Depth 100	0,60	32 x 3,5
Rectangular	Width 200 Depth 150	0,80	40 x 5
Rectangular	Width 250 Depth 200	1,00	40 x 6

The 5 mm and 6 mm thick brackets shall be hot dip galvanised after fabrication.

15.1.4.4 RAIN-WATER PIPES (METAL)

Sheet iron rain-water pipes shall be of 0,60 mm thick galvanised sheet iron, seamed at back and jointed with slip joints neatly soldered. Pipes shall be provided with offsets, elbows and shoes as required.

The pipes shall be fixed 25 mm clear of finished wall face on galvanised mild steel rain-water pipe brackets spaced at not exceeding 2,4 m apart, and having tails built into walls in 3:1 cement mortar.

15.1.4.5 SEAMLESS RAIN-WATER PIPES (ALUMINIUM)

Dimensions:

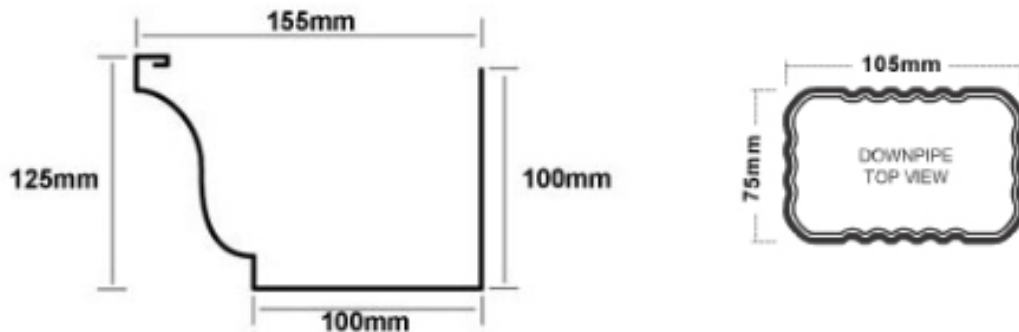

FIG. 1 OGEE GUTTER and DOWN PIPE

The aluminium rainwater goods shall be of seamless corrosion resistant type 3004 grade, pre-painted aluminium. All works will be executed in accordance with the manufacturer's instruction.

Material: Aluminium alloy shall be 0.6mm

Size and dimensions: Gutter to be role formed on site from seamless pre-painted aluminium coil to exact measurement. To be hung by 20mm x 2.5mm internal aluminium brackets at 600mm centres, to be secured with class three tex screws to the fascia board.

Gutter size and type: 155mm x 100mm Ogee gutter.

Down Pipe: 105mm x 75mm rectangular fluted aluminium down-pipe manufactured elsewhere.

Stop-ends: mitre joined on the corners, crimped at ends, and sealed at with approved sealer.

15.1.4.6 PROTECTION AGAINST LIGHTNING

The lightning protection shall be in accordance with the latest revision of SABS Code of Practice 03 and must comply with the performance requirements laid down therein.

Ir terminals and down-conductors:

All conductors must be of electrical conductor grade aluminium alloy.

Earthing electrodes:

Earthing electrodes must consist of either extensible copper clad steel rods not less than 12mm diameter driven into the ground or of 50mm² bare copper conductor buried in a trench or a combination thereof. Where extensible earthing rods are used these are to be manufactured from copper clad steel and have a molecular bond between the two metals to prevent the moisture ingres.

Joints:

Where it is necessary to join lengths of circular section conductor, this must be done by crimping and in the case of flat conductor by either double riveting using aluminium rivets, two bolts of at least 6mm diameter and nuts.

Bonds:

Where it is necessary to bond the aluminium conductor to any other metallic surface, this must be done by bolting or riveting.

Conductor guides:

The conductor must be mounted in aluminium alloy guides conforming with the material specification BSS 1476/H/E9, which allow free longitudinal movement of the conductor for expansion and contraction of the system due to temperature variation. The guides must be attached to the structure by screwing and plugging, using two screws, which must be suitably attached.

No part of the conductor system is to come into direct contact with concrete or plaster as this may cause the aluminium to corrode.

The conductor system should preferably be supported in guides so that an air gap exists at all times between the aluminium and concrete/plaster surface, the guides being seated upon plastic or other similar insulating material.

15.2 STORM-WATER DRAINAGE

15.2.1 CONCRETE PIPES

All storm-water drain pipes shall be of concrete complying with the requirements of SABS Specification 677 of SC Type and of Class B quality, all marked as laid down in the specification.

The pipes shall be socketed or have plain ends with loose collars. The loose collars shall be of the same material and manufacture as the pipes.

15.2.2 DRAIN LAYING

Storm-water drains shall be accurately laid to the lines and gradients shown on drawings with pipes of the diameters shown.

Socketed pipes shall be closely fitted together. Joints are to be filled with semi-dry mortar composed of not more than 2 parts fine washed sand and 1-part cement, well caulked in with a steel tool, all as laid down in SABS Code of Practice 058, but without gaskets and fillets.

Where loose collars are used, ends of pipes shall be butted together in stiff 2:1 cement mortar with space between pipes and collars filled with similar mortar and well caulked.

All bends, junctions, etc. for pipes up to and including 150 mm diameter shall be of vitrified clay as for soil and wastewater drains, including cement mortar jointing, but joints shall be without gaskets and fillets. Where one or more of the pipes are over 150 mm diameter, the bends and junctions shall be made with junction boxes as described in Clause 16.19.

Drains of different diameters shall be laid at such levels as will provide for the top of the pipe bores all being at the same level where the drains enter or leave chambers, catch pits and

junction boxes, and for the invert of the largest diameter drain being at bottom of the chamber, pit or box.

Level required, with the necessary bends.

Where pipes pass through foundation and similar walls, openings shall be formed in the walls for passage of the pipes.

Pipes shall be built into walls of chambers, catch pits, etc. in 2:1 cement mortar.

15.2.3 JUNCTION BOXES

Bends and junctions in storm-water drains, where one or more of the pipes are over 150 mm diameter, shall be made with junction boxes cast in position in Class C concrete, after the drains are laid. The bottoms and sides of boxes shall be not less than 150 mm thick and sides shall be carried up slightly above top of pipes and finished level on top. Each box shall be covered with an 80 mm thick slab of similar concrete, laid loose.

15.2.4 CATCH PITS

15.2.4.1 TYPE A

Catch pits Type A, shown on drawing "Drainage Details", shall be of size and of depth shown or required, built with 1 brick thick sides of extra hard burnt bricks in 3:1 cement mortar on 100 mm thick Class C concrete bottoms.

Each catch pit shall be fitted with an approved cast iron catch pit grating, of size required to match size of catch pit, set in an approved cast iron frame fitted with lugs and surrounded with a 100 mm thick kerb of Class C concrete, splayed down on top towards pit and finished where exposed with 2:1 cement mortar, trowelled smooth and rounded on salient angles.

15.2.4.2 TYPE B

Catch pits Type B, shown on drawing of "Drainage Details", shall be as described in Subclause 16.20.1, but kerbs around the gratings shall be of a thickness equal to the overall thickness of the surface channels discharging into catch pits and shall be rounded, sunk and splayed down on top as detailed, hollowed where surface channels connect to kerbs and finished where exposed with cement mortar as for surface channels.

15.2.4.3 TYPE C

Catch pits Type C, shown on drawing of "Drainage Details", shall be of size and depth shown, each formed with 150 mm thick bottom of Class C concrete and 1 brick thick walls built of extra hard burnt bricks in 3:1 cement mortar, fitted with grating constructed with 40 x 12 mm mild steel framing and 40 x 12 mm mild steel cross bars spaced at 40 mm centres, all welded together and set in rebates formed in kerb of Class C concrete as shown.

Kerbs shall be flush on top with surrounding ground or paving and splay finished with 2:1 cement mortar, trowelled smooth.

15.2.4.4 TYPE D

Catch pit Type D, shown on drawing of "Drainage Details", and as used in prison yards where one or more of the drain pipes entering or leaving the catch pits are 380 mm or more in diameter, shall be as described in Subclause 16.20.1, but concrete bottoms shall be 150 mm thick and each catch pit shall be fitted with an approved cast iron dished catch pit grating, hinged to a cast iron frame set in the concrete kerb. 20 mm Diameter mild steel bars shall be built in horizontally across drain pipe opening/openings with ends built 100 mm into the

brickwork. The bars shall be spaced one course apart with the lowest bar not more than two courses above invert of drain pipe and the uppermost bar not more than 150 mm from the top of the pipe bore.

15.2.5 SURFACE WATER DRAINS

Surface water drains shall be 1500mm wide formed of Class C concrete (cast in situ), not less than 75mm thick at any part, with drains having not less than 1000mm wide and 150mm deep segmental channels.

The drains shall be laid to even and sufficient falls on hard earth bottoms, and the *in situ* drains shall be finished on exposed surfaces with 2:1 cement mortar, trowelled smooth and rounded on salient edges.

All stopped and returned ends, angles, sweeps around gullies, etc. shall be neatly formed.

Drains exceeding 1,8m in length shall be cast in sections not more than 1,8m in length.

15.2.6 STORM-WATER MANHOLES

Manholes shall be provided to storm-water drains where indicated on drawings with 1 brick thick walls of extra hard burnt bricks in 3:1 cement mortar laid on 100 mm thick Class C concrete bottoms. Fit on top with Type 9C cast iron single seal manhole covers, each size (daylight) 600 x 450 mm and mass approximately 39 kg, unless otherwise specified, complying with the requirements of SABS Specification 558 and coated with an approved preservative solution before leaving the Manufacturer's works with frames of covers bedded in 150 mm thick surrounds of Class C concrete, splayed on top and finished with 2:1 cement mortar, trowelled smooth and rounded on salient angles.

Manholes shall be of the types and sizes specified in the table hereunder for the various depths of drains, viz.:

Type	Depth of drain	Size of manhole	
		Length (m)	Width (m)
A B	Under 0,6 m	0,6	0,45
	0,6 m and under 1,5m	0,9	0,6

Bottom of manholes and walls to a height of 450 mm or to the top of the pipes entering or leaving the manholes, whichever is the higher, shall be rendered with 3:1 cement plaster. Brickwork above the plaster shall be built to a fair face and neatly struck jointed.

15.3 SOIL AND WASTE-WATER DRAINAGE

15.3.1 PIPES IN GENERAL (FOR DRAINAGE):

15.3.1.1 PIPE CONNECTIONS:

Connections between pipes of different materials shall be formed as described below:

CONNECTION	METHOD OF JOINTING
Between socketed cast iron and vitrified clay pipes and vice versa,	Semi-dry caulking cement and 2:1 cement mortar fillet.

Between hubless cast iron pipes and fittings.

Approved stainless steel-neoprene "No-Hub" couplings with stainless steel bands and worm drive clamps.

Between mild steel or copper and clay pipes.

Semi-dry caulking cement and 2:1 vitrified cement mortar fillet, or bitumen.

Between lead and vitrified clay pipes.

Brass ferrule wiped onto lead pipe and caulked in vitrified clay pipe socket with bitumen or semi-dry caulking cement and 2:1 cement mortar fillet.

15.3.1.2 GENERAL:

Diagonally fixed or unsightly vertical surface mounted waste pipes must not be allowed to spoil the external appearance of buildings at ground floor level.

If other suitable solutions cannot be found, metallic waste pipes up to a maximum of 40 mm in diameter, may be chased into walls by special permission of the Representative/Agent and plastered over or built into floors provided that adequate permanently accessible cleaning eyes are provided.

At ground floor level external "P" traps should be used for soil fittings. Where these become unsightly because of large differences in level or where they are unsightly because they are situated in prominent positions, "S" traps in conjunction with manholes should be employed. Generally, "S" traps should be used with the greatest discretion as they are difficult to clean.

Vertical 100 mm vent pipes at heads of drains should be placed inside lavatories, store rooms or other suitable places.

All other drainage work on buildings higher than single storey should preferably be housed in easily accessible properly designed drainage ducts. If this is not possible, exposed soil and waste water drainage work should be placed inside lavatory accommodation or store rooms, but must be neatly executed with straight lines and without any unsightly bends etc.

Where drainage work in important rooms or spaces is considered to be unsightly it should be encased in a composite timber board duct with suitable access panels.

15.3.2 CLEANING EYES

Cleaning eyes shall be provided to drains in the positions indicated on the drawings by the letters "CE" (or "SO") each formed by inserting junction in the drain, or bend at end of drain, and bringing a branch up to ground level with easy bends, the vertical pipe being of same diameter as the drain, and fitting top of pipe at ground level with approved cast iron access branch and cover with the letters "CE" (or "SO") cast on the cover. The cover shall be set in tallow and secured with non-ferrous metal screws and the branch shall be jointed to socket of clay pipe with jointing as described for drain pipes.

The vertical bends and pipes shall be bedded on and encased in Class C concrete from bottom of trench up to ground level, not less than 100 mm thick at any part and finished on top with 2:1 cement mortar, trowelled smooth and rounded on salient angles.

15.3.3 INSPECTION EYES

Inspection eyes shall be provided to drains in the positions indicated on the drawings by the letters "IE" (or "10") each formed by inserting an access pipe or bend in the drain and each fitted with oblong vitrified clay access lid sealed with bitumen.

When the letters "IE" (or "10") shown on the drawings are enclosed in a square, Class C concrete blocks, each size 350 x 350 x 75 mm, shall be provided at ground level directly over the inspection eyes.

These blocks shall be finished with 2:1 cement mortar, trowelled smooth and the letters "IE" (or "10") formed in the top surface.

15.3.4 GULLIES

Gullies shall be provided to drains where indicated on drawings, each formed with 100 mm diameter vitrified clay gully trap with gully head carried up to not less than 40 mm above finished ground level and provided with 50 mm diameter vertical and/or side inlets as required. Fit head with 190 mm diameter cast iron gully grating, laid loose in the socket.

The trap, vertical pipe and head shall be bedded on and encased in Class C concrete, not less than 100 mm thick at any part, and finished where exposed with 2:1 cement mortar, trowelled smooth, flush with top of gully head and splayed on edges.

15.3.5 UNIVERSAL TRAPS

Universal traps shall be provided to drains where indicated on drawings, each formed with vitrified clay trap and vertical shaft, all of same diameter as drain pipes, jointed together and to drain pipes as described for drains. The vertical shaft shall be carried up to not less than 40 mm above finished ground level and fitted on top with plain cast iron grating laid loose in the socket.

The trap and vertical shaft shall be bedded on and encased in Class C concrete, not less than 100 mm thick at any part, and finished where exposed with 2:1 cement mortar, trowelled smooth, flush with top of vertical shaft and splayed on edges.

15.3.6 URINAL TRAPS

Where urinals connect direct to drains, provide 75 or 100 mm diameter vitrified clay "P" traps under the urinal outlet with 100 mm vitrified clay vertical pipe and where outlet of urinal is 75 mm with 75 mm to 100 mm taper piece, all connected together as described for drain pipes and similarly connected to outlet nozzle of urinal, but with bitumen joint to tail piece of metal outlet grating where urinal is provided with such outlet.

The traps, vertical pipes and taper pieces shall be bedded on and encased in Class C concrete not less than 100 mm thick at any part,

15.3.7 INSPECTION CHAMBERS

Inspection chambers shall be provided to drains where indicated on drawings with 1 brick thick walls of extra hard burnt bricks in 3:1 cement mortar laid on 100 mm thick Class C concrete bottoms. Fit on top with Type 8A cast iron double seal manhole covers as described in Clause 16.36 with frames of covers bedded in 150 mm thick surrounds of Class C concrete, splayed on top and finished with 2:1 cement mortar, trowelled smooth and rounded on salient angles.

Chambers shall be of the types and sizes specified in table hereunder for the various depths of drains, viz:

Type	Depth of drain	Size of Manhole	
		Length (m)	Width (m)
A	Under 0,6 m	0,6	0,45
B	0,6 m to 1,5 m	0,9	0,6

Chambers shall be provided with half-round vitrified clay straight and curved channels, junctions, tapers, etc. as required, joined in 2:1 cement mortar and laid to regular falls, benched up to sides of chambers with Class C concrete, brought up vertically at sides of channels to same level as top of main drains and then sloped up to walls of chambers as shown and finished smooth with 1: 1 cement mortar. All edges of benching, angles, slopes, etc. shall be rounded off.

All pipes shall enter and leave at bottom of chambers.

Internal walls of chambers shall be rendered with 3:1 cement plaster above top of benching.

15.3.8 MANHOLE COVERS

Manhole covers to inspection chambers shall be of cast iron complying with the requirements of SABS Specification 558 and coated with an approved preservative solution before leaving the Manufacturer's works.

The covers shall be of the types, sizes and approximate mass specified in the table hereunder, viz:

TYPE	DESCRIPTION	NOMINAL SIZE (dia)	APPROXIMATE MASS (kg)
2A	Roadway type	550 dia	190
2B	Roadway type with ventilation openings	550 dia	180
8A	Double seal	600 x 450	72
PC	Single seal	600 x 450	39
9D	Single seal	600 x 450	74

15.3.9 SEPTIC TANK AND FRENCH DRAINS

15.3.9.1 SEPTIC TANK

The septic tank shall be constructed strictly as specified on the drawings for the septic tank.

15.3.9.2 FRENCH DRAINS

French drains shall be 0,6 m wide, of length shown and 1,8 m deep below invert of drain pipe where entering the drain. Build cavity chamber, size 300 x 300 mm internally, under end of drain pipe with dry rubble walls, in rough local hard stone, from bottom of trench up to top of drain pipe and fill remainder of trench in up to same level with clean, hard, durable stone, graded from a minimum of 40 mm to a maximum of 80 mm as shown.

The trench above the stone filling, shall be provided with approved bituminous or other suitable sheeting, laid over the stone filling and lapped 75 mm at joints.

Trench shall be filled in above sheeting with approved filling, lightly rammed.

15.3.10 SEWAGE PIPES AND FITTINGS

All sewage pipes and fittings used shall be of the PVC type bearing the SABS mark.

15.3.10.1 TESTING

The whole of the waste water drainage system shall be tested as described hereunder. The Contractor shall provide all necessary testing apparatus, expanding plugs, stoppers, water, smoke composition, any other materials that may be required and all labour required for carrying out tests.

15.3.10.2 PRELIMINARY OR OPEN TEST

All underground drains and fittings shall be tested before being covered in or encased in concrete by means of air pressure.

In carrying out the air test all openings in the drains shall be plugged or sealed and all traps associated therewith filled with water. Pump air into the drains until a manometric pressure of 40 mm is indicated after which, without further pumping, the pressure shall not drop below 25 mm for a period of at least 30 seconds.

The air test may be applied to the drains in one operation or drains may be divided into sections and each section tested separately.

Before carrying out the above test, an internal inspection of the drains shall be made with a torch and mirror in the direction of the flow. The drains shall be free of invert lips and the bore of the pipes shall be straight.

15.3.10.3 FINAL TEST

After the drainage has been completed, all plumbing fittings installed and permanently connected up and trap seals filled with water, a final air test as described in PPS PD 10.1 above, shall be applied to the whole system.

15.3.10.4 DEFECTS TO BE MADE GOOD

Should the drainage system fail to withstand the tests described in 15.23.1 and 15.23.2 above, all defects causing such failure shall be made good and the test repeated until the whole of the work is shown to be thoroughly sound and tight, all to the entire satisfaction of the Employer's Representative.

In making good all defective parts shall be carefully cut out and replaced with new in a proper manner. No patching of pipes, joints or connections will be allowed.

15.4 WATER SUPPLIES, FIRE SERVICE AND SANITARY PLUMBING AND FITTINGS

15.4.1 MILD STEEL PIPES

Mild steel water piping shall be in accordance with SABS Specification 62, galvanised inside and outside with screwed ends and shall be of medium class complete with sockets, ends, elbows, tees, long-screws, back nuts and other fittings as may be required, all complying with the requirements of SABS Specification 509.

Screwed joints shall be made with lead paint and PTFE tape to cold water piping.

Cut ends of pipes shall be reamed out to remove burrs.

Pipes shall be firmly and neatly built in or fixed to walls as directed by the Employer's Agent Representative.

In order that no air may lodge in the pipes, a proper inclination shall be maintained in fixing same.

If practicable, bends shall be used at angles in preference to elbows. If a reduction in the size of the pipe takes place at an angle, the bend or elbow shall be of the size of the inlet or larger pipe.

No surface mounted water piping will be permitted on external wall surfaces except for a short distance of vertical rising main from ground level.

15.4.2 POLYETHYLENE PIPES

Polyethylene pipes shall be in accordance with SANS 4427/ISO 4427 and bear the SABS Mark. The pipe diameters and Class shall be as indicated on the drawings.

Compression joints made with compression fittings shall be used for joining pipes. Take care to use the size of fitting intended specifically for the pipe to be joined. The end of the pipe is inserted into the fitting past the rubber sealing ring and, by turning of a threaded nut, a grip ring is compressed between the fitting and the pipe until it grips the outer surface of the pipe to prevent the pipe from pulling out of the fitting.

Except at points of positive anchorage, ensure that holder-bats, clips, brackets, etc. used to support the pipe do not grip the pipe and that they allow back-and-forth movements caused by temperature changes to take place freely and without risk of abrasion of the pipe.

Ensure that supports provide a flat smooth bearing surface without sharp edges. Firmly mounted all types of manual controls, and valves in particular, to minimize the movement transmitted to the pipe by operation of the control handwheel or handle.

Where a pipe has side connections, these connections, unless at a point of anchorage, will be subject to any thermal movement of the pipe. Each side connection shall therefore be supported at a point that is far enough away from the main pipe to ensure that excessive lateral bending does not occur in the connection.

Continuous support of the pipe is necessary and the spacing of supports shall not exceed 500mm.

15.4.3 COPPER PIPES

Copper pipes for domestic cold water and gas services in all cases shall comply with the requirements of SABS Specification 460 Class 0, 2 and 3. For applications below ground only Class 2 or 3 shall be used.

Pipework above ground shall be of Class 0 or 2 jointed with capillary soldered fittings. Provision must be made for union couplings in strategic places.

All copper pipes shall be jointed with approved capillary solder type fittings, each joint being formed by cutting the pipe-ends, preferably with a pipe cutter. If the tube end, to be soldered, is dirty due to cement, bitumen or tape-gum, it should be mechanically cleaned with steel wool or abrasive paper. After inserting the pipe into the fitting, apply a flame using LPG gas blow lamp to the assembly to heat the tube and fitting for not longer than about 10 seconds. Then remove the flame completely and test the temperature of the joint by placing the wire solder at the mouth of the fitting. If the solder does not melt, remove the solder and heat again with the flame for a few seconds more. If the solder melts freely, hold the solder at about 45° to the mouth of the fitting, allowing it to melt and with steady pressure the solder will be drawn into the joint.

Use only 2mm solid core wire solder. Type 97/3. A careful check should be made to ensure that a ring of solder is visible around the mouth of the fitting.

Fittings and pipes must be wiped clean with a damp cloth after jointing. Joints that have been fluxed should be soldered within 1 hour.

15.4.4 SANITARY FITTINGS

Prices of WC suites shall be deemed to include the following: WC pan, flushvalve or 11 litre cistern with flushing apparatus, float valve and flush pipe and all finishings to pipes and cistern.

15.4.4.1 SUNDRY FITTINGS

Toilet roll holders:

Chromium plated brass thief proof toilet roll holder shall be fitted to wall.

Towel rails:

Chromium plated brass or aluminium towel rail with brackets shall be fitted to wall.

15.4.4.2 PEDESTAL WATER CLOSET PANS

Pedestal water closet pans shall be of the washdown type, approximately 400 mm high, of white glazed fireclay or vitreous china, complying with the requirements of SABS Specification 497.

The pans shall have "P" traps with straight outlets or right or left hand side outlets, as required.

Pans shall be bedded onto the floors in 3:1 cement mortar.

The pans shall be fitted with approved solid hardwood or plastic double flap seats having open fronts and of size and shape required to fit the pans, each attached to the pan with non-ferrous metal fixing bolts.

15.4.4.3 FLUSHING CISTERNS

Low level cisterns shall be of the valveless siphonic type or of the flushing valve type, each with body and removable cover of white glazed fireclay or vitreous china complying with the requirements of SABS Specification 497.

Flush pipes to flushing cisterns shall have an internal diameter of not less than 34 mm for the various lengths of pipe under 1,5 m.

15.4.4.4 WASH HAND BASINS

Wash hand basins shall be of the bracket type with back skirting of white glazed fireclay or vitreous china complying with the requirements of SABS Specification 497 having weir type overflow and fitted with chromium plated grid or slot type overflow.

Basins shall be 558 x 406 mm, each fitted with an approved 32 mm chromium plated brass waste fitting with screwed outlet complete with vulcanite or rubber plug attached to basin with chromium plated chain, two 15 mm chromium plated brass, easy clean pattern, screw down pillar taps where hot and cold water is supplied to basin.

Basins shall be fixed on approved white enamelled cast iron brackets, fixed to walls with M6 bolts, 120 mm long, built into walls in 3:1 cement mortar.

15.4.4.5 WALL MOUNTED BOWL URINALS

Wall mounted urinals shall be of white glazed fireclay or vitreous china type, each approximately 700 x 300 mm in overall size, with back flush entry and secured to wall with not less than two concealed hanger brackets. The urinals shall each be fitted with 38 mm diameter chromium plated domical grating, approved urinal flushing valve complete with push button assembly, spreader and all other necessary chromium plated fittings.

Fit each urinal outlet with a chromium plated bottle trap.

15.4.5 WATER STORAGE TANKS

15.4.5.1 MAIN WATER TANK AND TANK STAND

The main water storage tank connected to the main water supply system shall be a polythene tank mounted on a steel tank stand supplied by the manufacturer of the water tank to ensure that the bottom of the water tank shall be 3,0m above the natural ground level. The polythene water tank shall be manufactured from LLDPE, UV stabilized raw materials, and comply with F&DA regulation 177.1520 for food contact application, and carry a minimum five (5) year manufacturer's guarantee. The tank size shall be 10 000 litres. The tank must be supplied with at least a 40mm inlet connector at the top, a 40mm outlet connector at the bottom, and a 450mm lid.

The tank stand shall be manufactured from steel and shall be designed and supplied by the tank manufacturer to their specifications.

All water installations must be neat and watertight without any leakages and be tested.

15.4.5.2 RAINWATER HARVESTING WATER TANK AND TANK STAND

The polythene water tanks shall be manufactured from LLDPE, UV stabilized raw materials, and comply with F&DA regulation 177.1520 for food contact application, and carry a minimum five (5) year manufacturer's guarantee. Each tank size shall be 5 000 litres. The tanks must be supplied with at least a 40mm inlet connector at the top, a 40mm outlet connector at the bottom, and a 450mm lid. Each tank must be supplied with a 25mm outlet adaptor at its bottom and 25mm brass tap which comply to SABS Specification 226, securely mounted on the stand.

The tank base shall be constructed as per specifications on the drawing. All specifications applicable under concrete work and masonry work will apply.

All water installations must be neat and watertight without any leakages and be tested. The stand must be constructed to the specification on the plan to a height of at least 0.6m high. The water tank must be securely tied down and mounted on the stand and must have a 25mm tap.

15.4.6 WATER TAPS AND VALVES

All water taps and stop cocks shall comply with the requirements of SABS Specification 226.

Taps for hot water shall be marked with the letter "H" or with the word "Hot" or shall have red colour plastic inserts, and taps for cold water, when both cold and hot taps are provided to a fitting, shall be marked with the letter "C" or with the word "Cold" or shall have green or blue colour plastic inserts.

Ball valves shall comply with the requirements of SABS Specification 752.

15.4.7 FIRE HOSE REELS

30 Meter long 20 mm diameter fire hoses that comply with SABS Specifications 988, 1096 and 543 with reels (non-swivel type) that comply with SABS Specification 543, including all valves, nossels, etc., all to the approval of the Fire Brigade and in accordance with SABS Code of Practice 0400 as specified, must be provided.

Contractor is to fix fire hose reels against walls with 10 mm diameter hook or rag bolts, not less than 150 mm long and build into walls in 3:1 cement mortar.

Centre of fire hose reel to be approximately 2,1 m above floor level.

Provide the reel with an approved slide-over type fibre glass security cupboard or a high impact resistant, UV-stabilised, clear acrylic cover with a numbered twist-action closer seal if so specified.

15.4.8 FIRE EXTINGUISHERS

Supply number and type of fire extinguishers as specified, all in accordance with SABS Code of Practice 0400 and to the approval of the local Fire Brigade.

Hang extinguishers on appropriate approved wall mounted hangers at heights as directed.

All extinguishers to be of the refillable handheld portable types according to the capacities indicated.

- a) Dry powder (DCP) extinguishers in accordance with SABS Specification 810.
- b) CO₂ extinguishers in accordance with SABS Specifications 1151.
- c) BCF (1211) extinguishers in accordance with SABS Specification 1511.

Hang the fire extinguishers at an appropriate height against a permanent support.

15.4.8.1 TESTING OF PLUMBING

The plumbing work shall be tested in accordance with the instructions of the Employer's Agent Representative and any imperfect work shall be taken out and renewed at the cost of the Contractor and again tested until found to be perfect.

15.4.9 TESTING OF WATER RETICULATION AND PIPELINES

Before carrying out the pressure test of water reticulation and pipelines the entire system must be filled with water and all air evacuated.

The test shall be carried out by pressurising the water in the system to one and a half times the expected working pressure that the installation is designed for, by means of a pump. The pressure shall be maintained at that level for a period of at least two hours during which time all pipes, joints and fittings are to be thoroughly inspected.

Any leakages that may appear must be repaired to the satisfaction of the Employer's Agent Representative. When the system is connected to the main water supply and is operational a final inspection must be carried out under normal working pressure and any defects shall be rectified.

PC 15 MEASUREMENT AND PAYMENT

Item	Unit
PC 15.1 Eaves gutters, on and including gutter brackets at not exceeding 1m centres metre (m)	

The unit of measurement shall be the metre length of eaves gutters, on and including gutter brackets at not exceeding 1m centres fixed strictly in accordance with the manufacturer's instructions.

The tendered rate for the gutters shall include full compensation for the supply of all labour and materials, transport of all materials to site, cutting of gutters, fixing to roofs in accordance with the manufacturers instructions and the making good thereof.

Item	Unit
PC 15.2 Extra over eaves gutter for outletNumber (No)	

The unit of measurement shall be the number of eaves gutter outlets fixed strictly in accordance with the manufacturer's instructions.

The tendered rate for the gutters outlets include full compensation for the supply of all labour and materials, transport of all materials to site, fixing to eaves gutters in accordance with the manufacturers instructions and the making good thereof.

Item	Unit
PC 15.3 Rainwater downpipes, fixed with and including holderbats to walls at not exceeding 1,5m centres metre (m)	

The unit of measurement shall be the metre length of Rainwater downpipes, fixed with and including holderbats to walls at not exceeding 1,5m centres fixed strictly in accordance with the manufacturer's instructions.

The tendered rate for the rainwater downpipes shall include full compensation for the supply of all labour and materials, transport of all materials to site, cutting of downpipes, fixing to walls in accordance with the manufacturer's instructions and the making good thereof.

Item	Unit
PC 15.4 Extra over downpipes for eaves offset Number (No)	

The unit of measurement shall be the number of eaves offset, fixed strictly in accordance with the manufacturer's instructions.

The tendered rate for the offsets shall include full compensation for the supply of all labour and materials, transport of all materials to site, fixing to gutters in accordance with the manufacturer's instructions and the making good thereof.

Item **Unit**

PC 15.5 Extra over downpipes for shoe Number (No)

The unit of measurement shall be the number of shoes, fixed strictly in accordance with the manufacturer's instructions.

The tendered rate for the shoes shall include full compensation for the supply of all labour and materials, transport of all materials to site, fixing of shoes to downpipes in accordance with the manufacturer's instructions and the making good thereof.

Item **Unit**

PC 15.6 Extra over eaves gutter for angle Number (No)

The unit of measurement shall be the number of angles, fixed strictly in accordance with the manufacturer's instructions.

The tendered rate for the angles shall include full compensation for the supply of all labour and materials, transport of all materials to site, fixing of angles to downpipes in accordance with the manufacturer's instructions and the making good thereof.

Item **Unit**

PC 15.7 Protection against lightning Number (No)

The unit of measurement shall be the number of ir terminals and earthing electrodes fixed strictly in accordance with the manufacturer's instructions.

The tendered rate for the ir terminals and earthing electrodes shall include full compensation for the supply of all labour and materials, transport of all materials to site, fixing of ir terminals and earthing electrodes to building in accordance with the manufacturer's instructions and the making good thereof.

Item **Unit**

PC 15.8 Mass Concrete for surface drains cast in panels to be at slope
..... cubic metre (m³)

The unit of measurement shall be the cubic metre of mass concrete for surface drains cast in panels to be at a slope.

The tendered rates shall include full compensation for the design of concrete mixes and all testing of concrete and materials other than compressive strength testing of concrete samples from concrete being placed in the works (the Contractor shall only be entitled to payment for those samples and compressive strength tests called for by the Engineer and which pass the test requirements), handling and depositing (by hoisting or lowering) concrete in the forms, working and packing concrete around reinforcement, all "construction joints" other than "designated joints" as defined in SABS Specification 1200G which are given separately, shaping tops of components as required and striking off and curing.

Item	Unit
PC 15.9 Septic tank and French drain	Sum

The unit of measurement shall be the sum total for the complete construction and installation of septic tank and French drain.

The tendered rates shall include full compensation for the supply of all labour and materials, transport of all materials to site, construction of septic tank and French drain strictly in accordance with the supplied drawings and specifications, linking the sewer system up with the septic tank and the making good thereof.

Item	Unit
PC 15.10 Sewer reticulation system	Sum

The unit of measurement shall be the sum total for the complete installation of the sewer reticulation system from the buildings to the septic tank.

The tendered rates shall include full compensation for the supply of all labour and materials, transport of all materials to site, excavations, laying of sewer pipes, testing, backfilling and connection to sanitary equipment strictly in accordance with the supplied drawings and specifications, linking the sewer system up with the septic tank and the making good thereof

Item	Unit
PC 15.11 5 000 litre Poythene rainwater tank	Number (No)

The unit of measurement shall be the number of 5 000 litre polythene tanks, fixed onto the tankstands.

The tendered rate for the tanks shall include full compensation for the supply of all labour and materials including connectors, reducers, pipes, elbows, brass tap, etc. for complete rainwater tank, transport of all materials to site, fixing of tanks, pipeline and taps to tankstands in accordance with the manufacturer's instructions and the making good thereof.

Item	Unit
PC 15.12 Extra over tank stand for rainwater harvest tank	Number (No)

The unit of measurement shall be the number of tank stands constructed according to drawings and specifications.

The tendered rate for the tank stands shall include full compensation for the supply of all labour and materials, transport of all materials to site, construction of tankstands in accordance with the drawings and specifications and the making good thereof.

Item	Unit
PC 15.13 10 000 litre Polythene water tank	Number (No)

The unit of measurement shall be the number of 10 000 litre polythene tanks, fixed onto the tankstands.

The tendered rate for the tanks shall include full compensation for the supply of all labour and materials, transport of all materials to site, fixing of tanks to tankstands in accordance with the manufacturer's instructions and the making good thereof.

Item	Unit
PC 15.14 Extra over tank stand for water tank	Number (No)

The unit of measurement shall be the number of tank stands supplied and erected strictly according to the manufacturer's instructions.

The tendered rate for the tank stand shall include full compensation for the supply of all labour and materials, transport of all materials to site, erection of tankstand in accordance with the manufacturer's instructions and the making good thereof.

Item	Unit
PC 15.15 Polythene pipes	metre (m)

The unit of measurement shall be the metre of polythene pipe layed according to the specifications.

The tendered rate for the polythene pipes shall include full compensation for the supply of all labour and materials, transport of all materials to site, cutting and laying of pipes in accordance with the manufacturer's instructions and the making good thereof.

Item	Unit
PC 15.16 Extra over Polythene pipes for fittings	Number (No)

The unit of measurement shall be the number of polythene pipe fittings supplied and installed according to the manufacturer's instructions.

The tendered rate for the polythene pipe fittings shall include full compensation for the supply of all labour and materials, transport of all materials to site, fixing of pipe fittings in accordance with the manufacturer's instructions and the making good thereof.

Item	Unit
PC 15.17 Galvanised steel pipes	metre (m)

The unit of measurement shall be the metre of galvanised steel pipe layed according to the specifications.

The tendered rate for the galvanised steel pipes shall include full compensation for the supply of all labour and materials, transport of all materials to site, cutting, laying and fixing of pipes in accordance with the manufacturer's instructions and the making good thereof.

Item	Unit
PC 15.18 Extra over galvanised steel pipes for fittings	Number (No)

The unit of measurement shall be the number of galvanised steel pipe fittings supplied and installed according to the manufacturer's instructions.

The tendered rate for the galvanised steel pipe fittings shall include full compensation for the supply of all labour and materials, transport of all materials to site, fixing of pipe fittings in accordance with the manufacturer's instructions and the making good thereof.

Item	Unit
PC 15.19 Copper pipes	metre (m)

The unit of measurement shall be the metre length of Copper pipe layed according to the specifications.

The tendered rate for the copper pipes shall include full compensation for the supply of all labour and materials, transport of all materials to site, cutting, laying and fixing of pipes in accordance with the manufacturer's instructions and the making good thereof.

Item	Unit
PC 15.20 Extra over copper pipes for fittings	Number (No)

The unit of measurement shall be the number of copper pipe fittings supplied and installed according to the manufacturer's instructions.

The tendered rate for the copper pipe fittings shall include full compensation for the supply of all labour and materials, transport of all materials to site, fixing of pipe fittings in accordance with the manufacturer's instructions and the making good thereof.

Item	Unit
PC 15.21 Testing water pipe system	Sum

The unit of measurement shall be the sum total for the testing of the water pipe system according to the specifications.

The tendered rate for the testing of the water pipe system shall include all labor, plant and equipment for the testing of the water pipe system, testing of the system and the making good thereof.

Item	Unit
PC 15.22 Sanitary fittings	Number (No.)

The unit of measurement shall be the number of each type of sanitary fitting installed strictly according to the specifications.

The tendered rate for the sanitary fittings shall include all labor, plant and material for the installation of the sanitary fittings, testing of the fittings and the making good thereof.

Item	Unit
PC 15.23 Fire hose reels	Number (No)

The unit of measurement shall be the number of fire hose reels installed strictly according to the specifications.

The tendered rate for the firehose reels shall include all labor, plant and equipment for the installation of the fire hose reels, testing thereof and the making good thereof.

Item

Unit

PC 15.24 Fire extinguishers Number (No)

The unit of measurement shall be the number of fire extinguishers installed strictly according to the specifications.

The tendered rate for the fire extinguishers shall include all labor, plant and equipment for the installation of the fire extinguishers.

16 SECTION 16: PAINTING

16.1 PREPARATORY WORK FOR PAINTING

All floors shall be swept clean, walls dusted down and surfaces not being painted covered and protected against spotting before any painting is carried out.

On woodwork:

Woodwork being painted shall be well brushed down, knots treated and all surfaces primed, stopped with hard stopping and rubbed down to an even surface ready to receive the paint.

On metalwork:

All metal surfaces being painted, except for structural steelwork, shall be cleaned of all rust, scale and dirt, removed by scraping or with steel wire brushes. All oil and grease shall also be removed and a perfectly clean surface obtained.

New galvanised metal surfaces, which are to be painted, shall be cleaned down as above and given 1 coat of self-etching wash primer complying with the requirements of SABS Specification 723.

Protective coatings on new galvanised metal surfaces, applied by the Manufacturer to prevent storage stain and white rust, shall be completely removed by the use of suitable cleaning agent and the surfaces thoroughly rinsed and allowed to dry before the surfaces are primed.

After removing rust from metalwork those portions so affected shall be treated with an approved rust inhibitor or rust neutralising paint.

On plaster:

All plastered walls, ceilings and such like surfaces being painted shall be filled, where necessary, with suitable or patching plaster and the whole rubbed down ready to receive the finishings.

16.2 SURFACES TO BE DRY

All wall, ceiling and similar plastered surfaces shall be perfectly dry and in a fit state to receive paint finishes, before the application of any paint.

Special care is to be taken when the plaster is specified to be finished with oil based paints.

16.3 PAINTS

a) Plastered walls:

Apply one coat Plaster Primer and two coats Polyurethane Enamel paint (White) to new interior walls.

Apply one coat Plaster Primer and two coats Plascon Wall and All (or similar) paint (White) to new exterior walls.

b) Doors:

Apply three coats Polyurethane Enamel paint (White), lightly sanded between coats.

c) Door- and Window frames:

Apply three coats Polyurethane Enamel paint (White), lightly sanded between coats.

d) Metal works for fixing gutters and welded mesh fence to:

Prime using red oxide zinc chromate primer. Finish with three coats Polyurethane Enamel paint (White).

16.4 APPLICATION OF PAINT

All coats shall be thoroughly dry and where necessary rubbed down before subsequent coats are applied.

Application of paint shall be brush or roller.

16.5 PRIMING

All surfaces normally primed before being painted shall be prepared and primed as described in readiness to receive the specified paint system.

16.6 LEAVE PERFECT

The Contractor shall provide all necessary dust sheets, covers, etc. and shall exercise all necessary care to prevent marking surfaces, walls, floors, glass, electrical fittings etc. and shall keep all parts of the works perfectly clean and free at all times from spotting, accumulation of rubbish, debris or dirt arising from the operations.

The premises shall be left clean and fit for occupation at completion of the work.

PC 16 MEASUREMENT AND PAYMENT

Item	Unit
PC 16.1 Paint one coat undercoat and two coats flexible durable paint on plastered walls	Square metre (m ²)

The unit of measurement shall be the square metre plastered walls to be painted and shall be deemed to include the preparation of the surfaces including filling, stopping, sanding and priming of nail heads and screws all in accordance with the manufacturer's instructions.

The tendered rate for the painting of walls shall include full compensation for the supply of all labour and materials, transport of all materials to site, preparation of the surfaces including filling, stopping, sanding and priming of nail heads and screws and the painting of the walls in accordance with the manufacturer's instructions.

17 SECTION 17: ELECTRICAL INSTALLATION

17.1 GENERAL

17.1.1 INTRODUCTION

- (a) These Standard Specifications cover the general technical requirements for the equipment, materials, installation, testing, commissioning and maintenance of electrical installations for the Department. These requirements shall be read in conjunction with the Documents as specified below.
- (b) "Document" shall mean the complete set of contract documents, including the Department's Tender Conditions, Tender Qualifications, the Standard Specification and the Detail Technical Specification including all drawings and variation orders issued in terms of the contract.
- (c) "Contractor" shall mean the person, partnership, company or firm appointed for the supply, installation, testing, commissioning and maintenance of the Electrical Installation. In the case of the Electrical Installation being a sub contract, nominated in terms of the Main Contract or otherwise, the word "Contractor" shall also mean "Sub Contractor" in terms of the Sub Contract Conditions for the specific installation. Where applicable the Builder or Principal Contractor shall be referred to as "Main Contractor".

17.1.2 INSTALLATION WORK

- (a) The complete installation shall comply with the requirements of this Specification. Should any discrepancies or contradictions exist between this specification and the Detail Technical Specification for the specific installation, then the latter shall take precedence.

In the event of discrepancies between the drawings, specifications and bill of quantities the Employer's Agent Representative shall decide whether the work as executed shall be remeasured on site or whether remeasurement shall be effected from the working drawings only.
- (b) The Employer's Agent's Representative will inspect the installation from time to time during the progress of the work. Discrepancies will be pointed out to the Contractor and these shall be remedied at the Contractor's expense. Under no circumstances shall these inspections relieve the Contractor of his obligations in terms of the Documents.
- (c) The Contractor shall notify the Employer's Agent's Representative timeously when the installation reaches important stages of completion (e.g. before closing cable trenches, before casting concrete, etc.) so that the Employer's Agent's Representative may schedule his inspections in the best interest of all parties concerned.

17.1.3 REGULATIONS

- (a) The installation shall be erected and tested in accordance with the latest issues and amendments of the following Acts and regulations:
 - SABS 0142: "Code of Practice for the Wiring of Premises",
 - The Occupational Health and Safety Act, 1993 (Act 85 of 1993),
 - The Local Government Act 1998 (Act 10 of 1998 (Gauteng), municipal by-laws and any special requirements of the local supply authority,
 - The Fire Brigade Services Act 2000 (Act 14 of 2000),
 - The National Building Regulations and Building Standards Act 1996 (Act 29 of 1996),

- (b) The Contractor shall issue all notices and pay all of the required fees in respect of the installation to the authorities, and shall exempt the Client from all losses, claims, costs or expenditures which may arise as a result of the Contractor's negligence in complying with the requirements of the regulations.
- (c) It shall be assumed that the Contractor is conversant with the above-mentioned requirements. Should any requirement, by-law or regulation, which contradicts the requirements of this Document, apply or become applicable during erection of the Installation, such requirement, by-law or regulation shall overrule this Document and the Contractor shall immediately inform the Employer's Agent's Representative of such a contradiction. Under no circumstances shall the Contractor carry out any variations to the installation in terms of such contradictions without obtaining the written permission to do so from the Department.

17.1.4 SITE CONDITIONS

Tenderers are advised to visit the site and acquaint themselves with all local conditions pertaining to the execution of the installation before tender closing date. No claims from the Contractor which may arise from insufficient knowledge of site access, type of site, labour conditions, establishment space, transport and loading/unloading facilities, power and water supply, etc. will be considered after submission of tenders.

For services where prior permission is required before contractors can visit the site, a visit will be arranged for all interested parties.

17.1.5 ARRANGEMENTS WITH THE SUPPLY AUTHORITY

- (a) The contractor shall give all notices required by and pay all necessary fees, including any inspection fees, which may be due to the local Supply Authority unless specified to the contrary.
- (b) It shall be the responsibility of the Contractor to make the necessary arrangements with the local Supply Authority at his own cost and to supply the labour, equipment and means to inspect, test and commission the installation to the satisfaction of the Local and Supply Authorities.
- (c) The Contractor shall supply and install all notices and warning signs that are required by the relevant laws, regulations and/or the Documents.

17.1.6 MATERIAL AND EQUIPMENT

- (a) All material and equipment shall conform in respect of quality, manufacture, tests and performance, with the requirements of the South African Bureau of Standards or where no such standards exist, with the relevant current Specification of the British Standards Institution.
- (b) All material and equipment shall be of high quality and suitable for the conditions on site. These conditions shall include weather conditions as well as conditions under which materials are installed, stored and used. Should the materials not be suitable for use under temporary site conditions then the Contractor shall at his own cost provide suitable protection until these unfavourable site conditions cease to exist.
- (d) The Contractor shall, where requested to do so, submit samples of equipment and material to the Employer's Agent's Representative for approval prior to installation. Samples may be retained in the Employer's Agent's Representative's possession until the contract is completed after which they will be returned.

17.1.7 CONNECTIONS INVOLVING ALUMINIUM (CABLES AND TRANSFORMERS)

As a result of the fact that aluminium flows when subjected to pressure and electrical connections based on this principle thus loses proper contact during the course of time, it should be noted that bolted connections between aluminium and copper or any other metal is not acceptable.

17.1.8 CODES OF PRACTICE OR STANDARD SPECIFICATION

Where reference is made to any Code of Practice or Standard Specification in this document the latest edition or amendment shall be applicable, except where specified to the contrary.

17.2 INSTALLATION AND TERMINATION OF CONDUITS AND CONDUIT ACCESSORIES

17.2.1 GENERAL

17.2.1.1 SCOPE

This section covers the installation of conduits and conduit accessories in buildings and other structures under normal environmental conditions and for system voltages up to 600 V.

1 The following types of conduit installations are included:

- (a) Screwed metallic conduit black enamelled and galvanised.
- (b) Plain end metallic conduit black enamelled and galvanised.
- (c) Non-metallic conduit.
- (d) Flexible conduit.

2 Conduits may be installed as follows:

- (a) In open roof spaces.
- (b) Cast in concrete.
- (c) Surface mounted against walls, concrete slabs, etc.
- (d) In wall chases.

3 Where conduits are to be installed in concrete, this shall be undertaken while the building work is still in progress. Conduits may only be surface mounted where specified or where the Employer's Representative has given its written consent.

4 Under no circumstances will conduit having a wall thickness of less than 1,6mm be allowed in screeding laid on top of concrete slabs.

5 Bending and setting of conduit must be done with special bending apparatus manufactured for the purpose and which are obtainable from the manufacturers of the conduit systems. Damage to conduit resulting from the use of incorrect bending apparatus or methods applied must on indication by the Employer's Representative, be completely removed and rectified and any wiring already drawn into such damaged conduits must be completely renewed at the contractor's expense.

6 Tenderers must ensure that general approval of the proposed conduit system to be used is obtained from the local electricity supply authority prior to the submission of

their tender. Under no circumstances will consideration be given by the Employer's Representative to any claim submitted by the contractor, which may result from a lack of knowledge in regard to the supply authority's requirements.

- 7 For light and socket outlet circuits, the conduit used shall have an external diameter of 20mm. In all other instances the sizes of conduit shall be in accordance with the "Wiring Code" for the specified number and size of conductors, unless otherwise directed in part 2 of this specification or indicated on the drawings.

17.2.1.2 OTHER SERVICES

Conduits may not be installed closer than 150 mm to pipes containing gas, steam, hot water or other materials, which may damage the conduits or conductors. Conduits may not touch pipes of other service installations in order to prevent electrolytic corrosion. Where this is unavoidable, cathodic protection shall be provided.

Conduit and conduit accessories used for flame-proof or explosion proof installations and for the suspension of luminaries as well as all load bearing conduit shall in all instances be of the metallic screwed type.

17.2.2 SCREWED METALLIC CONDUIT

17.2.2.1 GENERAL

- 1 In general, screwed steel conduit shall be used in the wiring of buildings.
- 2 The installation shall comply with SANS 10142.

17.2.2.2 GALVANISED CONDUIT

Galvanised conduit and accessories shall be used in the following:

- (a) In damp areas.
- (b) In areas exposed to the weather.
- (c) For all installations within 50 km of the coast.
- (d) In plenum chambers containing humidifying equipment.
- (e) For surface mounted conduit installations in kitchens and boiler rooms.
- (f) In screeds resting directly on soil.
- (g) For connection points to future installations.
- (h) For underground conduit containing earthing conductors.
- (i) In buildings where animals are housed such as cattle, sheep, dogs, etc.

17.2.2.3 TERMINATIONS

- 1 Spouted Connections.

Conduits shall be connected directly to draw-boxes with spouted connections. Conduits shall be screwed tightly home and no threads shall be visible.

- 2 Switchboards, Power skirting, etc.

Conduits shall be terminated by means of a brass female bush and two locknuts in pressed steel switchboards and distribution boxes, cable ducts, power skirting, etc. The conduit end shall only project far enough through the entry hole to accommodate the bush and locknut. Alternatively, the method detailed in 2.3.3 may be used.

- 3 Draw-boxes.

A female bush and two locknuts shall be used to terminate conduits at draw-boxes and outlet boxes without spouts, should there be sufficient room in the box. Where there is insufficient room, a coupling, brass male bush and locknut may be used with sufficient allowance for the reduction of the internal diameter by the male bush.

4 Holes.

Holes to accommodate brass bushes shall be large enough to accommodate the bush with a minimum of clearance.

5 Bush-nuts.

Bush-nuts for the connection of earth conductors to conduits are not acceptable.

17.2.2.4 SCREWS, BOLTS AND NUTS

Steel locknuts of thick gauge steel with milled sides shall be used in all cases. Cadmium-plated bolts and nuts shall be used except where the installation is exposed to the weather in which case brass bolts and nuts shall be used. Screws shall be installed in all tapped holes in fittings and accessories to prevent damage to the screw thread by concrete or plaster. The screws shall be screwed completely down to prevent damage to the thread on the screw.

17.2.2.5 CONDUIT ENDS

Conduit ends shall be cut at right angles to ensure that ends butt squarely at joints. Threads shall not be visible at joints and connections except at running joints. The total length of the thread on the two conduit ends shall not exceed the length of the coupling.

17.2.2.6 JOINTS

All conduit ends shall be reamed and all joints tightly screwed. Only approved couplings shall be used. Running joints with long threads shall be kept to a minimum and locknuts shall be provided to ensure a strong mechanical and a continuous electrical joint. Running joints in screwed conduit are to be avoided as far as possible and all conduit systems shall be set or bent to the required angles. The use of normal bends must be kept to a minimum with exception of larger diameter conduits where the use of such bends is essential.

17.2.2.7 FINISH

All joints shall be painted with red lead to prevent them from rusting in damp areas, areas within 50 km of the coast and in cases where the installation is exposed to the weather for any length of time. Where the galvanising or black paint has been damaged, the area shall first be cleaned and a coat of zinc base paint applied subsequently. Additional coats of paint shall only be applied after the undercoat has completely dried. All surface mounted non galvanised metallic conduit must be painted.

17.2.2.8 CONTINUITY

Mechanical and electrical continuity shall be maintained throughout the conduit installation.

17.2.3 PLAIN END METALLIC CONDUIT

As an alternative to the screwed conduit, plain-end conduit complying with:

- Unthreaded conduit shall be manufactured of mild steel with a minimum thickness of 1,2mm and shall comply with SANS 1065.

- Bending and setting of conduit shall be done with the correct apparatus recommended by the manufacturer of the conduit.
 - The Contractor or Supplier shall be responsible for obtaining the approval of local authorities for the use of this system.
 - All conduit and accessories used in areas within 50 km of the coast shall be hot-dip galvanised to SANS 32 & 121. In inland areas electro-galvanised or cadmium-plated accessories will be accepted.
- 1 Bending and setting of plain-end conduit must be done with special benders and apparatus manufactured for this purpose and which are obtainable from the suppliers of the system. Damaged conduit resulting from the use of incorrect bending apparatus shall be completely removed and any wiring already drawn into such damaged conduits shall be completely renewed at the Contractor's expense.
 - 2 Screwed conduit must be used in the following instances:
 - (a) In flameproof installations.
 - (b) Load bearing conduit.
 - (c) For the suspension of luminaries.
 - (d) Surface mounted conduit.
 - 3 Plain-end conduit and associated accessories shall be manufactured of mild steel having a minimum thickness of 1,2 mm and shall comply with SANS 1065. Conduit manufactured of lighter gauge material, i.e. 0,97 mm, will not be permitted.
 - 4 All conduit and accessories used in areas within 50 km of the coast shall be hot-dip galvanised to SANS 32 & 121. In inland areas Electro-galvanised or cadmium-plated accessories will be accepted.

17.2.4 NON METALLIC CONDUIT

17.2.4.1 INSTALLATION CONDITIONS

Where specified for a particular service, non-metallic conduit may be installed under the following conditions:

- 1 All non-metallic conduit shall comply fully with SANS 950 and shall be installed in accordance with Appendix C of the same specification as well as SANS 10142.
- 2 Insulated heat-resistant boxes shall be used for outlets of totally enclosed luminaries and other fittings where excessive temperatures are likely to occur.
- 3 Luminaries and other fittings shall not be supported by non-metallic conduit or conduit boxes. These fittings shall be secured to the surrounding structure in a way that is acceptable to the Employer's Agent's Representative. Refer to the standard specification for "INSTALLATION OF LUMINAIRES",
- 4 The conduit shall be supported and fixed with saddles with a maximum spacing of 1 m, even in roof spaces. (Refer to SANS 10142.) The Contractor shall supply and install all additional supporting timbers required.
- 5 It shall be possible to rewire the completed installation in the future without undue difficulty.
- 6 Non-metallic conduit and fittings shall not be used under the following conditions:
 - (a) Outside a building (unless protected, or sheltered under eaves).

- (b) For mechanical load bearing.
- (c) Where they may be subjected to temperatures below -10°C or above 70°C for prolonged periods.
- (d) As primary electrical insulation.
- (e) In areas where they may be subject to mechanical damage.
- (f) For applications other than those for which they are designed.
- (g) In concrete slab unless specified to the contrary.

17.2.4.2 PAINTING OF CONDUITS

Exposed conduit may be painted with normal oil or PVA paints, but care must be taken to ensure that the paint used does not contain any component that will soften or have any other detrimental effect on the materials from which the conduit and fittings are manufactured.

17.2.4.3 CONNECTING OF CONDUIT TO METAL EQUIPMENT/COMPONENTS

When any part of a non-metallic conduit system has to be connected to metal equipment or components (e.g. switchboard, surface socket-outlet or switch box, existing metallic conduit system, etc.) fittings and joints manufactured specifically for this purpose must be used. Non-metallic conduit must not be threaded to fit metallic connectors.

17.2.4.4 BENDS

In conduit of nominal size not exceeding 25 mm, bends may be made in accordance with par. 17. 2.4.5. In all other cases bends must be achieved by the use of accessories that are introduced into the conduit run. Bends shall comply with SANS 10142.

17.2.4.5 BENDING

Conduit of nominal size up to and including 25mm may be cold bent by hand provided that the radius of the bend is greater than six times the nominal size of the conduit, and that the external angle of the bend does not exceed 90° . The procedure (which involves the use of a bending spring) should be as follows:

- (a) Determine the angle through which the conduit is to be bent.
- (b) Warm the cold conduit over the length to be bent by rubbing with hands.
- (c) Select a bending spring which matches the conduit size and insert in to the conduit at the point where the bend is required.
- (d) Bend the conduit slowly with one motion (either with the hands alone approximately 1 m apart, or across the knee) to double the required angle, release the conduit and, when its position is stable, withdraw the bending spring (turning it in an anti-clockwise direction to reduce its diameter) and gently correct the angle.
- (e) Install and secure the conduit immediately following bending.

17.2.4.6 ADHESIVE JOINTS

All adhesive joints must be made in a clean dry area. The surfaces of all components to be bonded must be dry and clean.

The insertion depth should be marked on the conduit end and the adhesive applied (by means of a soft clean brush) as quickly as possible to the surfaces to be bonded by brushing lengthwise along the conduit, ensuring that a thin coating of uniform thickness is formed. The joint must be made immediately after the application of the adhesive by pushing the prepared parts squarely together with a twisting motion to the full insertion depth. Care must be taken to avoid squeezing adhesive into the cableway and all excess adhesive must be wiped off.

NOTE: Solvent adhesives contain highly volatile liquids and their containers should not be left open.

17.2.4.7 CUTTING

A fine-tooth hacksaw should be used to cut conduit to the required length. Each cut end should be square and free from swarf, burrs and loose material. When determining the length of conduit to be cut, allowance must be made for the length of couplings or accessories attached to the conduit. Incorrect determination will cause bulging of the conduit or insufficient joint length.

17.2.5 FLEXIBLE CONDUIT

- 1 In installations where the equipment has to be moved frequently to enable adjustment during normal operation, for the connection of motors or any other vibrating equipment, for the connection of thermostats and sensors on equipment and where otherwise required by the Employer's Agent's Representative, flexible conduit shall be used for the final connection to the equipment.
- 2 The installation shall comply with SANS 10142.
- 3 Flexible conduit shall preferably be connected to the remainder of the installation by means of a draw-box. The flexible conduit may be connected directly to the end of a conduit if an existing draw-box is available within 2 m of the junction and if the flexible conduit can easily be rewired.
- 4 Flexible conduit shall consist of metal-reinforced plastic conduit or PVC-covered metal conduit with an internal diameter of at least 15mm, unless approved to the contrary. In false ceiling voids, flexible conduit of galvanised steel construction may be used. Connectors for coupling to the flexible conduit shall be of the gland or screw-in type, manufactured of either brass or mild steel plated with either zinc or cadmium.

17.2.6 INSTALLATION REQUIREMENTS

17.2.6.1 POSITIONS OF OUTLETS

All accessories such as boxes for socket-outlets, switches, lights, etc. shall be accurately positioned. It is the responsibility of the Contractor to ensure that all outlets are installed level and square, at the correct height from the floor, ceiling or roof level and in the correct position relative to building lines and equipment positions as specified. It shall be the responsibility of the Contractor to determine the correct final floor, ceiling and roof levels in conjunction with the Main Contractor. Draw-boxes shall not be installed in positions where they will be inaccessible after completion of the installation. Draw-boxes shall be installed in inconspicuous positions to the approval of the Department's representative and shall be indicated on the "as built" drawings.

17.2.6.2 COVER PLATES

All draw boxes and outlets shall be fitted with cover plates, either as part of the switch or socket assembly or with blank cover plates if unused. Blank cover plates shall match other cover plates in the same area. Flush mounted cover plates in both ceilings and walls shall

overlap the draw-box and edges of the recess. If the fixing lugs are substantially deeper than the finished wall surfaces, suitable coiled steel wire or tubes shall be used as spacers.

17.2.6.3 DRAW-WIRES

Galvanised steel draw-wires shall be installed in all unwired conduits e.g. conduits for future extensions, telephone installations and other services.

17.2.6.4 BENDS

A maximum of two 90 bends or the equivalent displacement will be allowed between outlets and/or boxes.

Draw-boxes shall be installed at maximum intervals of 15 m in straight runs. All bends shall be made without heating the conduit or without reducing the diameter of the conduit. The inside radius of a bend shall not be less than five times the outside diameter of the conduit. (Refer to SANS 10142)

17.2.6.5 WALL SOCKET-OUTLETS

Where more than one socket-outlet is connected to the same circuit, the conduit shall be looped from one outlet box to the following on the same circuit. Where a metal channel is used, the conduit may be installed from the channel directly to the outlet box on condition that the conductors can be looped from one outlet to the next without making any joints in the wires.

17.2.6.6 LUMINAIRES

Where the conduit end is used to support luminaires, a ball-and socket type lid shall be fitted to the pendant box in all cases where the conduit is longer than 500 mm. In all other cases a dome lid may be used. Where luminaires are specified which are fixed directly to the pendant box, the pendant box shall be fixed independently of the conduit installation except where the pendant box is cast into concrete.

17.2.6.7 FLUSH MOUNTED OUTLET BOXES

The edges of flush mounted outlet boxes shall not be deeper than 10 mm from the final surface. Spacer springs shall be used under screws where necessary.

17.2.6.8 EXCESS HOLES

All excess holes in draw-boxes or other conduit accessories shall be securely blanked off by means of brass plugs to render the installation vermin proof.

17.2.6.9 DEBRIS

Care shall be taken to prevent debris or moisture from entering conduits during and after installation. Conduit ends shall be sealed by means of a solid plug which shall be screwed to the conduit end. Conduits shall be cleaned and swabbed to remove oil, moisture or other debris that may be present before conductors are installed. Swabs shall not be attached to the conductors.

17.2.6.10 DEFECTS

Each length of conduit shall be inspected for defects and all burrs shall be removed. All conduits that are split, dented or otherwise damaged or any conduits with sharp internal edges shall be removed from site. The Contractor shall ensure that conduits are not blocked.

17.2.6.11 WITHDRAWAL OF CONDUCTORS

To ensure that all electrical conductors are easily withdrawable from conduits and to ensure that there are no joints in the conductors, the Employer's Agent's Representative will have the right to have the conductors of any circuit removed at his discretion. If the conductors are found to be in a satisfactory condition after having been withdrawn, the Department shall bear the cost of withdrawing and re-installing such conductors. If the conductors are found to have been damaged during installation or removal or if joints are found, they shall be replaced and the cost shall be borne by the Contractor.

17.2.7 INSTALLATION IN CONCRETE

17.2.7.1 TIMEOUS INSTALLATION

In order not to delay building operations, the Contractor shall ensure that all conduits and accessories which are to be cast in concrete are placed in position in good time. The Contractor or his representative shall be in attendance when the concrete is cast.

17.2.7.2 DRAW-BOXES

Draw-boxes, expansion joints and round ceiling boxes shall be installed where required and shall be neatly finished to match the finished slab and wall surfaces. Ceiling draw-boxes shall be of the deep type. In hollow block slabs, rear-entry draw-boxes shall be used. In columns where flush mounted draw-boxes are installed, the conduits shall be offset from the surface of the column immediately after leaving the draw-box.

17.2.7.3 ELBOWS

Elbows for conduits of 32mm dia. and smaller and sharp bends will not be allowed in concrete slabs.

17.2.7.4 COVER PLATES

Draw-boxes and/or inspection boxes shall, where possible, be grouped together under a common approved cover plate, and must preferably installed in passages or male toilets. The cover plate shall be secured by means of screws.

17.2.7.5 NEUTRAL AXIS

All conduits shall be installed as close as possible to the neutral axis of concrete beams, slabs and columns. The conduits shall be rigidly secured to the reinforcing to prevent movement towards the surface of the concrete.

17.2.7.6 FIXING TO THE SHUTTERING

All conduits, draw-boxes etc. shall be securely fixed to the shuttering to prevent displacement when concrete is cast. Draw-boxes and outlet boxes shall preferably be secured by means of a bolt and nut installed from the back of the box through the shuttering. Fixing lugs may also be used to screw the boxes to the shuttering. Wire will not be accepted for securing boxes to the shuttering where off-shutter finishes are required. Where fibreglass shuttering is used by the Builder, the equipment shall be fixed to the steel only and no holes shall be drilled or made in shuttering. All draw-boxes and outlet boxes shall be plugged with wet paper before they are secured to the shuttering.

Before any concrete slabs are cast, all conduit droppers to switchboards shall be neatly spaced and rigidly fixed.

17.2.7.7 CONCRETE FLOOR SLABS

Conduits will not be allowed in concrete floor slabs of boiler rooms (or boiler houses), laundries or other damp areas. All socket outlets and three phase outlets in damp areas shall be supplied from above with galvanised conduit and accessories.

17.2.7.8 EXPANSION JOINTS

As far as possible, conduits shall not be installed across expansion joints. Where this is unavoidable a conduit expansion joint shall be provided.

17.2.7.9 SCREEDS

The installation of conduits in floor screeds shall be kept to a minimum. Where conduits are installed in screeds, the top of the conduit shall be at least 20 mm below the surface of the screed. Where the screed is laid directly on the ground, galvanised conduits shall be used. This ruling will always be applicable to the lowest floor of a building. A minimum distance of twice the outside diameter of the conduit shall be left free between adjoining conduits. Conduits shall be secured to the concrete slab at intervals not exceeding 2 m. The Contractor shall ensure that conduits are not visible above the screed where the conduits leave the screed.

17.2.7.10 INSPECTION

All draw-boxes, conduits, etc. which are installed in concrete shall be cleaned with compressed air and provided with draw-wires two days after removal of the shuttering. Errors that occurred during the installation of the conduits, or any lost draw-boxes, or blocked conduits shall be immediately reported to the Employer's Agent's Representative by telephone and confirmed in writing in order that an alternative route can be planned and approved by the Employer's Agent's Representative before the additional concrete is cast. Any additional cost shall be for the Contractor's account.

17.2.8 SURFACE INSTALLATIONS AND INSTALLATIONS IN ROOF SPACES

Wherever possible, the conduit installation is to be concealed in the building work; however, where unavoidable or otherwise specified, conduit installed on the surface must be plumbed or levelled and only straight lengths shall be used.

17.2.8.1 APPEARANCE

- (a) All conduits shall be installed horizontally or vertically as determined by the route and the Contractor shall take all measures to ensure a neat installation.
- (b) Where conduits are to be installed directly alongside door frames, beams, etc. that are not true, conduits shall be installed parallel to the frames, beams, etc.
- (c) All labels shall be removed from surface mounted conduit.

17.2.8.2 SADDLES

Conduits shall be firmly secured by means of saddles and screws and in accordance with SANS 10142. Where saddles are used to secure vertical lengths of conduit connected to surface mounted switch boxes or socket outlet boxes, the saddles shall be spaced so that the intervals between the box and the first saddle, between any two successive saddles and between the last saddle and the ceiling or roof are equidistant. Conduits shall be secured within 150 mm before and after each 90° bend and within 100mm of each outlet box.

17.2.8.3 JOINTS

Joints will only be allowed in surface conduit lengths exceeding 3,5 m. Threads shall not be visible at joints of completed installations, except where running joints are used. Running joints will be allowed only when absolutely necessary. All running joints shall be provided with locknuts and shall be painted with red lead immediately after installation.

17.2.8.4 ACCESSORIES

Inspection bends or tee pieces shall not be used. Non-inspection type bends may be used in the case of 32mm or 50 mm diameter conduits. All draw-boxes supporting luminaries or other equipment shall be fixed independently of the conduit installation.

17.2.8.5 OFFSETS

Where an offset is required at conduit terminations or crossovers, the conduit shall be saddled at the offset.

17.2.8.6 CROSS OVER

Conduit routes shall be carefully planned to avoid crossovers. Where a crossover is inevitable, one conduit only shall be offset to cross the other. Crossovers shall be as short as possible and shall be uniform. Alternatively, crossovers shall be installed in purpose-made boxes. This method shall be employed on face brick walls and in other circumstances where required by the Department.

17.2.8.7 PARALLEL CONDUIT

Parallel conduit runs shall be equidistant and saddles shall be installed in line. Alternatively, a special clamp may be used to secure all conduits in unison. In the case of conduits of different diameters, the latter method shall only be used if a purpose-made clamp designed to accommodate the various conduit sizes, is provided.

17.2.8.8 PAINTING OF CONDUIT

All surface mounted conduits and accessories shall be painted with two coats of a high quality enamel paint or as otherwise specified. The colour shall comply with the colour code specified for the installation or where no code has been specified, shall match the colour of the surrounding finishes.

17.2.8.9 CONDUIT IN ROOF SPACES

- 1 In open roof spaces (no ceiling) conduits shall run along the wall plates and the rafters. The installation of conduits suspended between the rafters is not acceptable.
- 2 Conduit in roof spaces shall be installed parallel or at right angles to the roof members and shall be secured at intervals not exceeding 1,5 m by means of saddles screwed to the roof timbers for metallic conduit and 1m for non-metallic conduit.
- 3 Nails or crampets will not be allowed.
- 4 Under flat roofs in false ceilings or where there is less than 900 mm clearance, or in instances where the ceilings are insulated with glass-wool or other insulating material impeding access, the conduit shall be installed in a manner which allows for wiring from below the ceilings.

- 5 Conduit runs from switchboards shall terminate in fabricated sheet steel draw-boxes installed directly above or in close proximity to the boards.
- 6 Spare conduits covering the total number of spare ways on switchboards, shall be provided between the boards and the roof draw box.
- 7 Where non metallic conduit has been specified for a particular service, the conduit shall be supported and fixed with saddles with a maximum spacing of 450mm throughout the installation. The contractor shall supply and install all additional supporting timbers in the roof space as required.

17.2.8.10 FIXING TO WALLS

Only approved plugging materials such as aluminium inserts, fibre plugs or plastic plugs, etc., and round-head screws shall be used when fixing saddles, switches, plugs etc. to walls. Wood plugs are not acceptable nor should plugs be installed in joints in brick walls.

17.2.9 FUTURE EXTENSIONS

17.2.9.1 OPEN ROOF SPACES

Conduits intended for future switches and socket outlets, shall terminate 40 mm above the tie beams in roof spaces with more than 900 mm free space. The conduit ends shall be threaded and fitted with a coupling and brass plug.

17.2.9.2 CONCRETE SLABS

Conduit ends shall protrude 150 mm from the concrete to facilitate the installation of future extensions above, below or to the side of the concrete slabs. All these conduits shall be connected to a draw-box, which is cast into the concrete within 2 m of the end of the concrete. Conduit ends shall be threaded and fitted with a coupling and brass plug. In cases where holes cannot be drilled through the shuttering to accommodate the conduit end, a deep draw-box with rear entry may be placed over the conduit end.

17.2.9.3 COVER PLATES

Unused boxes for switches and socket-outlets shall be covered with metal cover plates. Unused boxes for luminaries shall be covered with round galvanised metal cover plates, which fit tightly against the finished surface. The cover plate shall overlap the outlet box and recess.

17.2.9.4 GALVANISED CONDUIT

Galvanised conduit shall be installed at all free ends intended for future extensions. The conduit shall be treated with a paint, which will prevent corrosion and white rust.

17.2.10 EXPANSION JOINTS

- 1 Where conduits cross expansion joints in the structure, approved draw-boxes which provide a flexible connection in the conduit installation shall be installed.
- 2 The draw-box shall be installed adjacent to the expansion joint of the structure and a conduit sleeve, one size larger than that specified for the circuit, shall be provided on the side of the draw box nearest the joint. The one end of the sleeve shall terminate at the edge of the joint and the other shall be secured to the draw-box by means of locknuts.
- 3 The circuit conduit passing through the sleeve shall be terminated 40 mm inside the draw-box and in the case of metallic conduit, the conduit end shall be fitted with a

brass bush. The gap between the sleeve and the conduit at the joint shall be sealed with 'Pratley Tic-Tac' or equal sealing compound, to prevent the ingress of wet cement. In the case of metallic conduit, an earth clip shall be fitted to the conduit projection inside the draw-box and the conduit bonded to the box by means of 2,5mm² bare copper earth wire and a brass bolt and nut.

- 4 The end of the other circuit conduit shall be secured to the draw-box by means of locknuts and a brass bush in the case of screwed metallic conduit or a standard bushed adaptor for other conduit types.
- 5 In the case of metallic conduit, a 2,5mm² bare copper wire shall be installed between the first conduit boxes on either side of the joint, in addition to an earth wire, which may be specified for the circuit. The conduit boxes shall be drilled and tapped and the earth wire shall be bonded to the boxes by means of lugs and brass screws.
- 6 Suitable steel cover plates shall be screwed to draw-boxes installed along the expansion joint. The cover plates shall be installed before the ceilings are painted.
- 7 Where a number of conduits are installed in parallel they shall cross the expansion joint of the structure via a single draw-box. A number of draw-boxes adjacent to each other will not be allowed.

17.2.11 CHASES AND BUILDER'S WORK

- 1 Except where otherwise specified the Builder or Main Contractor shall be responsible for the builder's work related to the installation of conduits, outlet boxes, switchboard trays, bonding trays and other wall outlet boxes and will undertake the necessary chasing and cutting of walls and the provision of openings in ceilings and floors for luminaries and other electrical outlets. The Contractor shall notify the Builder or Main Contractor of his requirements and the responsibility lies with the Contractor to ensure that all builder's work is clearly indicated or marked in accordance with his requirements.
- 2 Electrical materials to be built in must be supplied, placed and fixed in position by the Contractor when required to do so by the Builder or Main Contractor. The Contractor shall also ensure that these materials are installed in the correct positions.
- 3 Where no Builder or Main Contractor is available, the Contractor must provide all chases and is required to cover conduits installed in chases by a layer of 4:1 mixture of coarse sand and cement, finished 6 mm below the face of the plaster and roughened. Chases shall be deep enough to ensure that the top of conduits are at least 12 mm below the finished surface of the plaster.
- 4 Where the Contractor is responsible for the cutting of chases or the building in of conduits and other equipment, he will be held responsible for all damage as a result of this work and will be required to make good to the satisfaction of the Employer's Agent's Representative.

This ruling is particularly applicable but not exclusively to the rewiring and renewal of existing installations. Chases shall be made by means of a cutting machine.

- 5 Under no circumstances shall face brick walls or finished surfaces be chased or cut without the written permission of the Employer's Agent's Representative. Where it is necessary to cut or drill holes in the concrete structure, the prior permission of the Employer's Agent's Representative shall be obtained.

17.3 INSTALLATION OF WIRING CHANNELS, UNDERFLOOR DUCTING AND POWER SKIRTING

17.3.1 RESPONSIBILITY OF THE CONTRACTOR

The Contractor shall supply and install all wiring channels, underfloor ducting and power skirting as specified or as required for the cable, socket outlet and wiring installation including the necessary supports, hangers, fixing materials, bends, angles, junctions, T-pieces, etc. He shall further liaise with the Main contractor to verify the position of holes and access routes through the structure and finishes.

17.3.2 WIRING CHANNELS

17.3.2.1 FIXING

The Contractor shall supply and install all hangers, supports or fixings for the channels. Channels up to and including 76 x 76 mm shall be supported at maximum intervals of 600 mm and larger channels at maximum intervals of 1 m. Channel runs shall be carefully planned to avoid clashes with other services and to ensure that all covers can be removed after completion of the entire installation. Purpose made clamps, hangers, etc. shall be used as required. Where it is not possible to support the channels at the specified intervals, they shall be supported in a sound manner to the satisfaction of the Department.

17.3.2.2 INSTALLATION IN CONCRETE

Where channels are cast into concrete, the insert type shall be used. Additional spacer blocks shall be used where necessary to prevent ducts from being deformed while the concrete is cast. Channels shall be filled with polystyrene or other suitable fillers to prevent the ingress of concrete and shall be securely fixed in position to the shuttering.

17.3.2.3 COVER PLATES

All channels up to and including 127mm width shall have snap-in cover plates of metal or PVC. Cover plates for wider channels shall be of metal and shall be fixed by means of screws at suitable intervals to prevent warping. Cover plates shall be installed over the full length of the channels. Flush mounted wiring channels shall be fitted with overlapping metal cover plates with plastic edge trim to cover irregularities in the wall recess.

17.3.2.4 JOINTS

Adjoining lengths shall be aligned and securely joined by means of fishplates fixed by mushroom bolts, washers and nuts or connection pieces that are pop-riveted to both adjoining sections. All adjoining sections shall be rectangular and shall butt tightly. Covers shall fit tightly across the joints.

Where channels cross expansion joints in the structure, suitable expansion joints shall be provided in the channels by means of fishplates pop-riveted or screwed to the channel on one side of the expansion joint and floating freely in the channel on the other side of the expansion joint.

17.3.2.5 SUPPORT FOR CONDUCTORS

All conductors in inverted cable channels shall be retained by means of metal clips or metal spacer bars at not more than 1m centres. Where vertical duct lengths exceed 5m, conductors installed in the channels shall be secured at intervals not exceeding 5m to support the weight of the conductors. Clamps shall be provided in suitable draw-boxes for this purpose.

17.3.2.6 CONDUIT CONNECTIONS

Conduit connections shall be terminated by means of two locknuts and a brass female bush. Where the channel is wide enough, conduit connections may be made by means of a conduit box and hole through the back or side of the channel. All holes through which conductors pass shall be fitted with bushes or grommets or shall be sleeved.

17.3.2.7 INTERNAL FINISHES

Bends and T-joints shall be constructed to ensure compliance with the allowable bending radii specified in SANS 10142, Appendix D in the case of PVC-insulated cables and conductors and shall comply with the relevant specification in the case of other cables. Burrs and sharp edges shall be removed and the inside edges of the joints shall be lined with rubber cement or other suitable rubberised or plastic compound to prevent laceration of the conductor insulation.

17.3.2.8 VERMIN PROOFING

All cable channels shall be vermin proofed after installation. Holes shall be covered by means of screwed metal plugs or by means of metal strips, which are bolted, or pop-riveted to the channel. Wooden or other plugs which are driven into holes or other temporary plugs or covers are not acceptable.

17.3.2.9 SERVICES

Multiple duct runs or internal metal partitions shall be used where conductors for power, control, communication and other services are present.

17.3.3 UNDERFLOOR DUCTING

17.3.3.1 GENERAL

- 1 Two or three compartment underfloor ducting as specified shall be supplied and installed in the positions and according to the layouts indicated on the drawings.
- 2 Three compartment ducting shall have a cross-section of approximately 200 x 32mm, subdivided into three approximately equal compartments, of which the centre compartment shall be used for electrical power distribution with the two outer compartments for telephone and other light current services respectively.
- 3 Unless specified, each compartment shall be provided with openings (occurring in line) at 1,5 m centres to permit installation of pedestals or recessed outlets in accordance with the design of the system. The openings shall have removable, flush, cover plates and shall have prepared fixing holes for future installation of pedestals or recessed outlets. The centre of the openings shall be offset a distance of 200 mm from the building nodule lines.

17.3.3.2 JUNCTIONS

The underfloor ducting installation shall be provided with flush cross-over, T junction and right angle bend draw-boxes installed in the runs of ducting, generally as indicated on the drawings. The junction boxes shall be complete with cross-over of services. The junction boxes shall have nominal 300 x 300mm removable cover plates secured by means of four countersunk screws.

17.3.3.3 PEDESTAL UNITS

Where the system accommodates floor pedestal units, these shall consist of pressed steel or die cast aluminium units, suitable for either two or three services, as specified in the Detail

Technical Specification. Where the pedestals are installed on vinyl tiled or similar floors which will be subject to washing, a matching waterproofing gasket shall be supplied below each pedestal to render the junction waterproof.

17.3.3.4 INSTALLATION

The underfloor ducting, junction boxes, pedestals, outlets and other accessories shall be installed strictly in accordance with the manufacturer's instructions and according to the following procedure:

- a) The underfloor ducting shall be installed on a mortar bed, provided by the Plasterer for purposes of levelling the channel to the final floor screed level. The Contractor shall assist the Plasterer in marking out the layout of the ducting to enable the mortar bed to be laid. Final height of the underfloor ducting shall be determined in close liaison with the Builder.
- b) After installation of the mortar bed, the components of the underfloor ducting shall be assembled and installed by the Contractor, following which the screeding will be completed.

17.3.3.5 TERMINATIONS

Up bends manufactured by the supplier of the underfloor ducting shall be supplied and installed wherever the ducting is terminated at a switchboard, telephone duct or telephone distribution box or where the ducting terminates behind power skirting.

17.3.3.6 WIRING

- 1 Power circuit wiring shall be installed in the centre compartment of the underfloor ducting. Sufficient slack shall be provided to allow for the installation of a floor pedestal outlet at each opening in the ducting, whether an outlet is specified at that position or not. This provision shall take the form of loops in the wiring, including the earth wire, wherever the openings occur. The loops shall be pushed back into the channel and the cover plates replaced. In the instances where pedestals/outlets are not installed, these provisions shall of necessity only be made for the area covered by the circuit and not for the run from the switchboard.
- 2 The entire underfloor ducting installation shall be effectively earthed and bonded together.
- 3 Galvanised draw-wires shall be supplied and installed along the entire length of the telephone and light current service compartments of the underfloor ducting. The draw wires shall be interrupted at the junction boxes, with enough slack left coiled up to facilitate the drawing in of cables by others.

17.3.3.7 EXPANSION JOINTS

Where expansion joints in the buildings are crossed by underfloor ducting, expansion joints shall be provided as detailed in PPS ES 2.4 of this section.

17.3.4 POWER SKIRTING

17.3.4.1 GENERAL

- 1 Two or three compartment power skirting as specified shall be supplied and installed in the positions and according to the layouts indicated on the drawings.
- 2 The top compartment shall be used for power wiring and switched socket outlets, whilst the bottom compartments shall be for telephone and other light current services.

17.3.4.2 MODULE

- 1 The power skirting shall be manufactured from 1mm (minimum) thick sheet steel or aluminium (as specified) in approximately 2,5m lengths.
- 2 The covers shall be manufactured in modular lengths, as specified in the Detail Technical Specification or otherwise in 1 m lengths and shall be secured to the wall channel by means of toggle or swivel nuts. Snap-in covers are also acceptable.
- 3 At the building module lines, covers of specified length or otherwise in 250 mm lengths shall be installed, against which partition walls may be installed, thereby trapping these covers. The removable modular covers shall be installed between these "fixed" covers.
- 4 Each modular cover associated with the power compartment shall be punched and prepared for the installation of either a 13A or a 16A, 3-pin standard flush switched socket outlet, whether any is specified or indicated for that module or not. Where socket outlets are not installed, the punched holes shall be blanked off with a metal blanking plate, painted the same colour as the power skirting and installed at the back of the covers. These blanking plates shall be easily removable to permit future installation of socket outlets.
- 5 Unless otherwise specified, no provision shall be made on the covers of the telephone or light current services compartments for the installation of sockets.
- 6 Factory-made end covers shall be installed at the ends of all runs of power skirting. All internal and external bends or offsets shall be factory-made and shall be installed to provide a neat and workmanlike appearance.

17.3.4.3 PAINTING

The power skirting shall be painted in a colour as specified in the Detail Technical Specification. Aluminium power skirting shall be anodised. The power skirting channels and covers shall be individually wrapped or packed to protect them against damage in transit and before installation.

17.3.4.4 SOCKET-OUTLETS

- 1 Standard 13 A or 16 A, 3-pin flush switched socket outlets (100 x 50 mm nominal size) shall be supplied and installed in the positions indicated on the drawings and as specified in the Detail Technical Specification.
- 2 The switched socket outlets shall be secured to the channel by means of suitable brackets.
- 3 After installation of the modular front covers, they shall be screwed to the socket outlets to ensure proper alignment between the two components. Separate standard covers need not be provided for the socket outlets.

17.3.4.5 CONDUIT FEEDERS

- 1 Conduits for the circuit wiring to the power skirting shall be installed in the floor slab and shall terminate in flush conduit or boxes, behind the power skirting and installed to match the height of the power, telephone and light current services compartments of the skirting.

- 2 The wiring/cables shall pass through large diameter holes cut in the rear of the power skirting. The holes shall be suitably bushed or trimmed to prevent damage to the wiring or cables.
- 3 Alternatively conduits feeding to the telephone compartment may be terminated in boxes facing upwards in the floor slab immediately below the power skirting, with suitable bushed or trimmed openings being provided through the bottom of the power skirting duct for the cables to pass through. (Applicable only where the power skirting occurs at floor level).

17.3.4.6 POWER SKIRTING AT DOORWAYS

Where a section of power skirting is interrupted by a doorway, bridging conduits shall be installed to interconnect the power skirting sections. Where conduits are not specifically indicated, a minimum of 1 x 32mm bridging conduit shall be installed for each of the power, light current and telephone compartments.

17.3.4.7 CLEANING

Prior to fitting front covers, the power skirting shall be thoroughly cleaned to remove all dust and rubble and damage to paintwork where this has occurred, shall be repaired.

17.4 INSTALLATION OF CABLE TRAYS AND LADDERS

17.4.1 GENERAL

Cable trays and cable ladders complying with the Department's specification shall be supplied and installed where specified and/or where generally suitable for cable distribution.

17.4.2 RESPONSIBILITY OF THE CONTRACTOR

The Contractor shall supply and install all cable trays and/or ladders as specified or as required by the cable routes including the necessary supports, clamps, hangers, fixing materials, bends, angles, junctions, reducers, T pieces etc. He shall further liaise with the Main Contractor for the provision of holes and access through the structure and finishes.

17.4.3 SUPPORTS

Cable tray supports shall consist of two steel hangar rods, at least 8mm in diameter, on both sides of the tray with a substantial steel cross-member on the underside of the tray and bolted to the rods. Alternatively, cable trays may be cantilevered from walls on suitable brackets.

17.4.4 SPACING OF HORIZONTAL SUPPORTS

- 1 Horizontal trays shall be supported at the following maximum intervals:
 - (a) 1,2 mm to 1,6 mm thick metal with 12mm to 19 mm return trays - 1m maximum spacing
 - (b) 2,5 mm thick metal trays with 76 mm return - 1,5m spacing.
 - (c) Cable ladders with 76mm side rail of 2mm thickness and with crossrungs - 1,5m spacing
 - (d) Metal cable ladders other than c) above, including site manufactured angle iron types - 1m spacing
 - (e) 3 mm thick PVC trays with 40mm return - 1m maximum spacing
 - (f) 4 mm thick PVC trays with 60mm return - 1,5m maximum spacing

- 2 In addition to the above spacing on the longitudinal run, trays and ladders shall be supported at each bend, offset and T-junction.

17.4.5 JOINTS

- 1 Joints shall be smooth and without projections or rough edges that may damage the cables. The Contractor will be required to cover joints with rubber cement or other non hardening rubberised or plastic compounds if in the opinion of the Department joints may damage cables.
- 2 Joints shall as far as possible be arranged to fall on supports. Where joints do not coincide with supports, joints shall be made by means of wrap-around splices of the same material as the tray and at least 450mm long. The two cable tray ends shall butt tightly at the centre of the splice and the splice shall be bolted to each cable tray by means of at least 8 round head bolts, nuts and washers. Splices shall have the same finish as the rest of the tray.
- 3 Splices as described above shall be provided at joints, which do coincide with supports if the loaded tray sags adjacent to the joint due to the interruption of the bending moment in the tray.

17.4.6 FIXING TO SUPPORTS

Trays shall be bolted to supports by at least two round head bolts per support. Bolts shall be securely tightened against the tray surface to avoid projections which might damage cables during installation.

17.4.7 FIXING TO THE STRUCTURE

- 1 Where installed on concrete or brick, the supports for cable trays and ladders shall be securely fixed by means of at least 2 heavy duty, expansion type anchor bolts. Cantilevered trays shall be supported by a minimum of two 6mm diameter expansion bolts per support.
- 2 It is the responsibility of the Contractor to ensure that adequate fixing is provided since cable trays and ladders that work loose shall be rectified at his expense. The fixing shall take into account site conditions that prevail during installation.
- 3 Where installed on vertical steelwork, cable trays and ladders shall be fixed by means of 6mm diameter bolts and nuts.
- 4 On horizontal steelwork, use may alternatively be made of "CADDY" type fasteners.
- 5 Horizontal trays and ladders shall in general be installed 450 mm below slabs, ceilings, etc. to facilitate access during installation of cables.
- 6 Multiple runs shall be spaced at least 300 mm apart unless a different spacing is specified in the Detail Technical Specification.

17.4.8 INSTALLATION OF CABLES

Cables shall be installed adjacent and parallel to each other on the trays, and snaked slightly to allow for expansion. Cables shall present a neat appearance and shall under no circumstances be bunched. Cables shall be clamped at maximum intervals of 3 m when installed on horizontal trays and at maximum intervals of 600 mm when installed on vertical trays.

17.4.9 EARTHING

Metal trays and ladders shall be bonded to the earth bar of the switchboard to which the cables are connected. Additional bare copper stranded conductors or copper tape shall be bolted to the tray or ladder where the electrical continuity cannot be guaranteed. These additional conductors or tapes shall always be installed in outdoor applications and in coastal regions.

17.4.10 CORROSION

PVC trays shall be used in corrosive atmospheres. All supports shall be adequately protected against corrosion, preferably with a powder coated paint finish.

17.5 FIXING MATERIALS

17.5.1 RESPONSIBILITY

It is the responsibility of the Contractor to position and securely fix conduits, ducts, cables and cable channels, switchboards, fittings and all other equipment or accessories as required for the Installation. The Contractor shall provide and fix all supports, clamps, brackets, hangers and other fixing materials.

17.5.2 FINISHING

All unpainted supporting steelwork installed by the Contractor shall be wire brushed and given one coat of rust-resisting primer, followed by one coat of high quality enamel paint before any other equipment is fixed.

17.5.3 STRUCTURAL STEEL

Supports, brackets, hangers, etc. may only be welded to structural steel members where prior permission of the Employer's Agent's Representative has been obtained. "CADDY" or similar fasteners may be used to fix equipment to structural steel members.

17.5.4 SCREWS AND BOLTS

Where holes exist in equipment to be fixed, bolts and fixing screws as specified shall be used. Where sizes are not specified, the largest bolt or screw that will fit into the hole shall be used.

17.5.5 WALL PLUGS

Where the fixing holes in brick or concrete walls are smaller than 10mm dia. and where the mass of the equipment is less than 10kg, wall plugs may be used to fix conduits, cables and other equipment. Fibre or plastic plugs shall be used. Wooden Plugs are not acceptable. Aluminium plugs may be used in face bricks. Plugs installed in joints between bricks are not acceptable. A masonry drill of the correct size shall be used to drill holes for plugs. Round-headed screws of the correct diameter to match the specific plug shall be used throughout.

17.5.6 ANCHOR BOLTS

Where the fixing holes are 10mm and larger or where the mass of the equipment is 10kg, equipment shall be fixed by means of expanding anchor bolts or by means of bolts cast into the concrete or built into walls.

17.5.7 GALVANISED EQUIPMENT

Brass screws bolts and nuts shall be used to fix galvanised equipment.

17.5.8 SHOT FIRED FIXING

- 1 Materials such as metal cable ducts or channels may be fixed against walls and concrete slabs by means of the shot-fired fixings.
- 2 The Contractor shall ascertain whether this method of fixing will carry the weight of the material including conductors, cables and other items of equipment to be installed later. Should it be found that the method of fixing is inadequate and supports tend to loosen, the Contractor will be required to fix the material by an alternative method to the satisfaction of the Employer's Agent's Representative.
- 3 Where the shot-fired method is used, warning signs shall be placed at all entrances leading to the area where this work is in progress. The Contractor shall take all reasonable precautions to prevent accidents. Refer also to The Occupational Health and Safety Act.
- 4 Nails and explosive charges recommended by the manufacturer shall be used throughout.

17.5.9 CLAMPS AND BRACKETS

Clamps and brackets used to fix or support equipment such as cable trays, ducts, etc. shall be of a purpose made type suitable for the specific application.

17.6 WIRING

This section covers wiring in approved wire-ways for electrical installations in buildings or other structures under normal environmental conditions for 50 Hz systems not exceeding 600 V.

17.6.1 TYPE OF CONDUCTORS

PVC-insulated or equivalent, stranded copper conductors and bare stranded or green PVC-insulated copper earth conductors shall be used exclusively. Only where cables are specified or in instances where the exceptions stipulated in SANS 10142 are applicable, may the Contractor deviate from this requirement.

17.6.2 WIRE-WAYS

- 1 All unarmoured conductors shall be installed in conduits, cable channels (trunking) or power skirting and shall under no circumstances be exposed. Cable channels and power skirting shall be of metal construction unless specifically approved to the contrary.
- 2 Tenderers must note that common wire-ways will only be permitted for relatively light current-carrying conductors such as lighting and socket-outlet circuits. Heavy current-carrying conductors such as feeders to distribution boards and large power points, must be installed in separate conduits or wire-ways.

17.6.3 ORDER OF WORK

Wiring shall only be carried out after the wire-way installation has been completed, but before painting has commenced. Debris and moisture shall be removed from the wireways prior to the installation of the conductors.

17.6.4 CIRCUITS

Conductors that are connected to different switchboards, shall not be installed in the same wireway. The wiring of one circuit only will be allowed in a 20 mm dia. conduit with the exception of the wiring from switchboards to fabricated sheet metal boxes close to switchboards in which case more than one circuit will be allowed. For larger conduit sizes the requirements of SANS 10142, shall be met.

17.6.5 LOOPING AND JOINTS

A loop-in wiring system where conductors are looped from outlet to outlet, shall be employed. Joints in conductors shall be avoided as far as possible but where it becomes unavoidable, joints will be accepted in cable channels only and not in conduits. Joints shall be soldered or shall alternatively consist of approved ferruling, properly covered with heat-shrink sleeves. The use of PVC insulation tape is not acceptable.

17.6.6 GROUPING OF CONDUCTORS

In cases where the conductors of more than one circuit are installed in the same wireway, the conductors of each separate circuit (including earth conductor) shall be taped at intervals of 1m with PVC insulation tape. The conductors of different circuits shall however remain separate in order that any given circuit can be withdrawn. Conductors entering switchboards or control boards shall be grouped and bound by means of plastic or metal bands (not tape).

17.6.7 CABLE TRAYS

Conductors may only be installed directly on cable trays if specifically approved by the Department. In these cases, cable trays shall be at least 2m above walkways or working areas. Conductors of the same circuit shall be grouped in the same manner as described in the previous paragraph. All the conductors on the cable tray shall then be tied down securely to the cable tray at intervals of 2m or less by means of plastic or metal bands (not tape).

17.6.8 DRAWING IN OF CONDUCTORS

When conductors are drawn through conduit, care shall be taken that they are not kinked or twisted. Care shall also be taken that the conductors do not come into contact with materials or surfaces that may damage or otherwise adversely affect the durability of the conductor.

17.6.9 THREE-PHASE OUTLETS

- 1 With the exception of three-phase outlets, circuits connected to different phases shall not normally be present at lighting, switch or socket outlet boxes. Where this is unavoidable, barriers shall be provided between terminals or connections of the various phases and the box shall be suitably labelled internally to indicate the presence of three phase voltages.
- 2 A neutral conductor shall be installed to all three phase outlets intended for equipment connection, whether sockets or isolators, irrespective of whether the particular equipment normally requires a neutral or not.

17.6.10 VERTICAL CONDUIT INSTALLATION

Conductors installed in vertical wire-ways shall be secured at intervals not exceeding 5m to support the weight of the conductors. Clamps shall be provided in suitable drawboxes for this purpose.

17.6.11 CONNECTIONS

The insulation of conductors shall only be removed over the portion of the conductors that enter the terminals of switches, socket outlets or other equipment. When more than one conductor enters a terminal, the strands shall be securely twisted together. Under no circumstances shall strands be cut off.

17.6.12 EARTHING CONDUCTORS

- 1 When earth continuity conductors are looped between terminals of equipment, the looped conductor ends shall be twisted together and then soldered or ferruled to ensure that earth continuity is maintained when the conductors are removed from a terminal.
- 2 The installation shall be earthed to comply with SANS 10142.
- 3 The installation shall be bonded to comply with SANS 10142.

17.6.13 COLOURS

The colours of conductor insulation shall comply with SANS 10142. The colours of conductors for sub-circuits shall as far as possible correspond with the colour of the supply phase. The colours of conductors for wiring to two-way and intermediate switches shall preferably differ from the colour of phase conductors.

17.6.14 SINGLE POLE SWITCHES

Single pole switches shall be connected to the phase conductor and not to the neutral conductor.

17.6.15 SIZE OF CONDUCTORS

Where conductor sizes are not specified, the following minimum conductor sizes shall be used:

Lighting circuits: - 1,5mm² and 2.5mm² copper earth conductor

Socket outlet circuits: - 2,5mm² and 2,5mm² copper earth conductor.

Bell circuits: - 1,5mm²

Stove circuits: - 10mm² and 6mm² copper earth conductor

Clock circuits: - 1,5mm²

17.6.16 PARTITIONS

- 1 When wiring is installed in removable partitions, the vertical and/or horizontal metal supports of the walls may be utilised for wiring on condition that:
 - (a) the conductors are not exposed,
 - (b) the metal supports are properly earthed,
 - (c) a separate bare earth continuity conductor is drawn in together with the current carrying conductors and is earthed to the metal parts of the switches and/or the socket outlets, and

- (d) conductors are installed in the metal and non-inflammable sections of the partitions.
- 2 Conductors enclosed in a copper braiding (harness wiring) may be installed in removable partitions. The braiding can be used as earth continuity conductor. The wiring shall be joined to the conduit (or cable) installation by interconnecting the conductor and the earth conductors in a draw-box using suitable ferrules and heat-shrink sleeves or screwed terminals.

17.7 INSTALLATION OF CABLES

This section covers the installation of cables for the distribution of power in buildings, other structures and in ground for system voltages up to 11 kV, 50 Hz.

17.7.1 GENERAL

1 CABLE TYPES

- (a) All cables and jointing and termination accessories used for power distribution shall comply with the requirements of the regulations of legislation listed in PPS EI 1.3.
- (b) Cables with copper conductors shall be used throughout unless otherwise specified or approved.
- (c) All unarmoured cables shall be installed in metal trunking, sleeves or conduit unless clearly specified to the contrary.
- (d) XLPE Cables shall only be used in exceptional circumstances with the written permission of the Employer's Representative.

2 COMPETENCE OF PERSONNEL

It is a definite requirement that the Contractor shall only employ personnel fully conversant with cable manufacturer's recommendations for joining and terminating cables.

17.7.2 IDENTIFICATION OF CABLES

- 1 Cables shall be identified at all terminations by means of punched metallic bands or marked with labels or tags. (Refer also to SANS 10142).
- 2 The use of PVC tape with punched characters is not acceptable.
- 3 The identification numbers of cables shall be shown on "as built" drawings of the Installation.

17.7.3 TRENCHING

17.7.3.1 GENERAL

- 1 The Contractor shall be responsible for all trenching excavations unless specified to the contrary.
- 2 The Contractor shall, before trenching commences, familiarise himself with the routes and site conditions and the procedure and order of doing the work shall be planned in conjunction with the general construction programme for other services and building requirements.

- 3 The Contractor shall acquaint himself with the position of all the existing services such as stormwater pipes, water mains, sewer mains, gas pipes, telephone cables, etc. before any excavations are commenced. For this purpose, he shall approach the Employer's Agent's Representative, the local municipal authority and any other authority which may be involved, in writing.
- 4 The Contractor will be held responsible for damage to any existing services brought to his attention by the relevant authorities and shall be responsible for the cost of repairs.
- 5 The Contractor shall take all the necessary precautions and provide the necessary warning signs and/or lights to ensure that the public and/or employees on site are not endangered.
- 6 The Contractor shall ensure that the excavations will not endanger existing structures, roads, railways, other site constructions or other property.

17.7.3.2 MECHANICAL EXCAVATORS

- 1 Power driven mechanical excavators may be used for trenching operations provided that they are not used in close proximity to other plant, services or other installations likely to be damaged by the use of such machinery.
- 2 The use of power driven mechanical excavators shall be subject to the approval of the Employer's Agent's Representative. Should the excavator produce trenches that exceed the required dimensions, payment based on volumetric excavation rates will be calculated on the required dimensions only.

17.7.3.3 BLASTING

- 1 No guarantee is given or implied that blasting will not be required.
- 2 Should blasting be necessary and approved by the Employer's Agent's Representative, the Contractor shall obtain the necessary authority from the relevant Government Departments and Local Authorities. The Contractor shall take full responsibility and observe all conditions and regulations set forth by the above authorities.

17.7.3.4 ROUTES

- 1 Trenches shall connect the points shown on the drawings in a straight line. Any deviations due to obstructions or existing services shall be approved by the Employer's Representative beforehand.
- 2 The Department reserves the right to alter any cable route or portion thereof in advance of cable laying. Payment in respect of any additional or wasted work involved shall be at the documented rates.
- 3 The removal of obstructions along the cable routes shall be subject to the approval of the Department.

17.7.3.5 SHORING AND WATERLOGGING

- 1 The Contractor shall provide shoring for use in locations where there is a danger of the sides of the trench collapsing due to waterlogging or other ground conditions. Refer to the The Occupational Health and Safety Act.
- 2 The strength of shoring must be adequate for site conditions prevailing and the shoring must be braced across the trench.

- 3 The Contractor shall provide all pumps and equipment required to remove accumulated water from trenches. Water or any other liquid removed shall be disposed of without any nuisance or hazard.

17.7.3.6 TRENCHING

- 1 Trenching shall be programmed in advance and the approved programme shall not be departed from except with the consent of the Employer's Agent's Representative.
- 2 Trenches shall be as straight as possible and shall be excavated to the dimensions indicated in this specification.
- 3 The bottom of the trench shall be of smooth contour, and shall have no sharp dips or rises which may cause tensile forces in the cable during backfilling.
- 4 The excavated material shall be placed adjacent to each trench in such a manner as to prevent nuisance, interference or damage to adjacent drains, gateways, trenches, water furrows, other works, properties or traffic. Where this is not possible the excavated materials shall be removed from site and returned for backfilling on completion of cable laying.
- 5 Surplus materials shall be removed from site and disposed of at the cost of the Contractor.
- 6 Trenches across roads, access ways or footpaths shall not be left open. If cables cannot be laid immediately the Contractor shall install temporary "bridges" or cover plates of sufficient strength to accommodate the traffic concerned.
- 7 In the event of damage to other services or structures during trenching operations the Contractor shall immediately notify the Employer's Representative and institute repairs.
- 8 Prior to cable laying the trench shall be inspected thoroughly and all objects likely to cause damage to the cables either during or after laying shall be removed.
- 9 Where ground conditions are likely to reduce maximum current carrying capacities of cables or where the cables are likely to be subjected to chemical or other damage or electrolytic action, the Employer's Agent's Representative shall be notified before installing the cables. The Employer's Agent's Representative will advise on the course of action to be taken.
- 10 Extreme care shall be taken not to disturb surveyor's pegs. These pegs shall not be covered with excavated material. If the surveyor's pegs are disturbed, they shall be replaced by a person qualified to do so.

17.7.3.7 DIMENSIONS OF TRENCHES

- 1 Cable trenches for one or two cables shall not be less than 300 mm wide and need not be more than 450 mm wide. This dimension shall be valid for the total trench depth.
- 2 The width shall be increased where more cables are installed to allow for the spacings stipulated.
- 3 Where trenches change direction or where cable slack is to be accommodated, the Contractor shall ensure that the requirements of the relevant SANS Specification regarding the bending radii of cables are met when determining trench widths.

- 4 Trench depths shall be determined in accordance with cable laying depths and bedding thickness.
- 5 Payment will be made on a volumetric excavation rate calculated on the basis of the given maximum dimensions or the actual dimensions, whichever is the lesser.

17.7.3.8 JOINT HOLES

Where cable joints are required to be made in the course of a cable run, a joint hole shall be excavated of sufficient size to enable the cable jointer to work efficiently and unimpeded.

17.7.3.9 BEDDING

- 1 The bottom of the trench shall be filled across the full width with a 75mm layer of suitable soil sifted through a 6mm mesh and levelled off.
- 2 Only sandy clay or loam soil with a satisfactory thermal resistivity (not exceeding 1,5°C m/W) may be used for this purpose. Sea or river sand, ash, chalk, peat, clinker or clayey soil shall not be used. The use of crusher sand is acceptable.
- 3 Where no suitable soil is available on site, the Contractor shall import fill from elsewhere and make all the necessary arrangements to do so. The cost of importing soil for bedding purposes shall be included in the unit rates for excavations.
- 4 After cable laying a further layer of bedding shall be provided to extend to 75 mm above the cables.
- 5 The bedding under joints shall be fully consolidated to prevent subsequent settling.

17.7.3.10 CABLE SLEEVES

- 1 Where cables cross under roads, railway tracks, other service areas, etc. and where cables enter buildings, the cables shall be installed in Polyethylene (6mm thickness), asbestos cement pipes or earthenware pipes. Pitch fibre and PVC pipes are not acceptable because of the adhesion that occurs after a period of time between the pipe and the sheathing or outer serving of the cables.
- 2 Pipes shall be joined in accordance with the manufacturer's instructions.
- 3 Sleeves shall cross roads and railway tracks at right angles.
- 4 Sleeves shall have a minimum diameter of 100mm. They shall extend at least 2m beyond the tracks of a railway line or of the outermost tracks where there is more than one line. In the case of roads, the sleeves shall extend at least 1m beyond the road edge or kerb on both sides of the road.
- 5 All sleeves shall be graded 1:400 for water drainage.
- 6 Cable sleeves shall be installed to the spacings and depths stated in paragraph 4 below.
- 7 Galvanised metallic sleeves up to and including 76mm dia. shall be supplied and installed by the contractor.
- 8 The ends of all sleeves shall be sealed with a non-hardening watertight compound after the installation of cables. All sleeves intended for future use shall likewise be sealed.

17.7.3.11 BACKFILLING

- 1 The Contractor shall not commence with the backfilling of trenches without prior notification to the Employer's Agent's Representative so that the cable installation may be inspected. Should the Contractor fail to give a timeous notification, the trenches shall be re-opened at the Contractor's cost. Such an inspection will not be unreasonably delayed.
- 2 For high voltage cables (1 kV to 11 kV) a coloured plastic marking tape shall be installed 400 mm above the cable. The tape shall be yellow, marked with the words "ELECTRIC CABLE/ELEKTRIESE KABEL" in red. These markings shall not be more than 1m apart from centre to centre.
- 3 Backfilling shall be undertaken with soil suitable to ensure settling without voids. The maximum allowable diameter of stones present in the backfill material, is 75mm.
- 4 The Contractor shall have allowed in his tender for the importation of suitable backfill material if required.
- 5 The backfill shall be compacted in layers of 150mm and sufficient allowance shall be made for final settlement. The Contractor shall maintain the refilled trench at his expense for the duration of the contract. Surplus material shall be removed from site and suitably disposed of.
- 6 On completion, the surface shall be made good to match the surrounding area.
- 7 In the case of roadways or paved areas the excavations shall be consolidated to the original density of the surrounding material and the surface finish reinstated.

17.7.3.12 CABLE MARKERS (FOR HV CABLES ONLY, EXCEPT WHERE OTHERWISE SPECIFIED)

- 1 Cable markers shall be provided along all HV cable routes but need only be provided along LV cable routes where specified.
- 2 Cable markers shall consist of concrete blocks in the shape of truncated pyramids, approx. 300mm high, 150 x 150mm at the top and 250 x 250mm at the bottom.
- 3 Brass plates shall be cast into the tops of the blocks in such a manner that they cannot be prised loose. The wording "ELECTRIC CABLE/ELEKTRIESE KABEL" shall be stamped on the brass plates as well as direction arrows and the cable voltage rating.
- 4 Cable markers shall be installed on the surface along all the underground routes and shall project 35 mm above normal ground level unless the projected markers could be a hazard to pedestrian or other traffic in which case they shall be installed flush with the surface.
- 5 Cable markers shall be installed at the beginning and end of a cable run (e.g. where a cable enters a substation or building), at all changes of direction, above all joints, above cable pipe entries and exits and at intervals not exceeding 50 m along the cable route.
- 6 The position of cable markers shall be indicated on the "as built" drawings.

17.7.4 INSTALLATION OF UNDERGROUND CABLES

17.7.4.1 INSTALLATION DEPTHS

- 1 Cables shall be installed at the following minimum depths below final ground level:

Up to 11kV: 800mm

- 2 All cable depth measurements shall be made to the top of the cable when laid directly in ground or to the top of the duct or sleeve where these are provided.
- 3 The above depths shall apply to the top layer where cables are installed in layers.
- 4 The Contractor may only deviate from the above depths provided prior authority in writing has been obtained from the Employer's Agent's Representative. In this event the cables shall be protected with a suitable concrete covering.
- 5 The depth of cable pipes or ducts beneath railway lines or roads shall be not less than 1,1 m below the formation level.

17.7.4.2 CABLE SPACINGS

- 1 Cables installed in the same trench shall be laid parallel to each other with the following spacings between cables (LV: up to 1 kV; HV: 1 kV to 11 kV):

LV/LV	:	2 cable diameters
LV/HV	:	150mm minimum
HV/HV	:	150mm minimum
LV/HV/PILOT	:	1 cable diameter
- 2 Where HV and LV cables have to be installed in the same trench, both shall be laid at a depth of 800 mm and then covered with 200mm of soil. The soil shall then be compacted, and then backfilled layer by layer and compacted until the trench is completely backfilled.
- 3 Cables for telephones, communication systems and other low voltage systems (less than 50 V) shall be separated from power cables by at least 1m. All control or pilot cables without a lead sheath and steel armouring shall be laid at least 300mm from power cables.
- 4 Cables shall not be buried on top of each other unless layers are specified. The minimum spacing between layers shall be 200mm.

17.7.4.3 CABLE LAYING

- 1 Except where ducts, tunnels or pipes are provided, cables shall be laid directly in the ground.
- 2 The cable shall be removed from the drum in such a manner that the cable is not subjected to twisting or tension exceeding that stipulated by the cable manufacturer.
- 3 Cable rollers shall be used as far as possible to run out cables. Rollers shall be spaced so that the length of cable in the trench will be totally suspended during the laying operation and sufficiently close to prevent undue sagging and the cable from touching the ground. Rollers shall also be placed in the trench in such a manner that they will not readily capsize.
- 4 Cable rollers shall have no sharp projecting parts liable to damage the cables.
- 5 Where cables have to be drawn around corners, well-lubricated skid plates shall be used. The skid plates shall be securely fixed between rollers and shall constantly be examined during cable laying operations.

- 6 Where cables have to be drawn through pipes or ducts, a suitable cable sock shall be used and particular care shall be exercised to avoid abrasion, elongation or distortion of any kind. In the case of oil filled cables, a cable sock may never be used. Special eyes giving access to the interior of the cable, must be utilised.
- 7 The maximum allowable tension when pulling a cable, is 70 N/mm² of conductor area.
- 8 It will be assumed that the price or rates contained in the tender includes for the installation of cables in pipes and ducts or below existing or newly installed services.
- 9 The Department shall be informed timeously of the intention to carry out all cable laying operations to allow an inspection of the works by the Employer's Agent's Representative if so required.

17.7.5 INSTALLATION OF CABLES IN CONCRETE TRENCHES

17.7.5.1 GENERAL

This paragraph covers the installation of cables in building trenches, service ducts, etc. The trenches, ducts, etc. inside buildings will be constructed and installed by others.

17.7.5.2 INSTALLATION

Cables shall be installed in one of the following ways:

- (a) On horizontal cable trays.
- (b) On horizontal metal supports with suitable clamps.
- (c) On vertical cable trays or metal supports fixed to the side of the trench. The cables shall be clamped in position.

Cables shall not be bunched and laid on the floor of the building trenches.

17.7.5.3 COVERS

- 1 The covering of concrete trenches shall as a rule fall outside the scope of the electrical installation. The Contractor shall however be responsible for the cutting or drilling and smoothing of holes for cables through chequer plates, concrete or other coverings as required.
- 2 Cables shall enter and exit the trench through sleeves protruding 300mm beyond the covering. The sleeves shall be permanently secured in position and the open space between the cable and sleeves shall be sealed with a non-hardening, watertight compound.

17.7.5.4 FILLED TRENCHES

- 1 Where specified, floor trenches shall be filled with fine crusher sand (no river or sea sand).
- 2 If a sand filling is specified, the cables shall be fixed to non-corroding supports.
- 3 Sand-filled trenches other than in substations shall be covered in one of the following ways:
 - (a) Reinforced concrete covers.
 - (b) Sand and cement screed.

(c) Removable chequer plates.

4 Method (a) above shall be used where vehicular traffic may be encountered over trenches. Unless otherwise specified allowance for a mass of 2 tons shall be made.

17.7.6 FIXING OF CABLES TO TRAYS OR STRUCTURES

17.7.6.1 INSTALLATION

Cables may be installed in one of the following ways:

- (a) On horizontal cable trays.
- (b) Against vertical cable trays with suitable clamps.
- (c) Against horizontal or vertical metal supports or brackets with suitable clamps.
- (d) On clamps which are fixed to the structure.

17.7.6.2 CLAMPS

Suitable clamps (cleats) which will secure cables without damage shall be used. Metal clamps or drilled hard wood blocks shall be used. Clamps shall consist of adjustable metal wings which clamp to a metal support, or consist of two halves that are bolted together. The correct clamp size to fit the cable shall be used. Cables of different sizes may only be fixed by a common clamp when the clamp is specially made to accommodate the various cables.

17.7.6.3 SPACING OF SUPPORTS

Two methods of supporting cables are found in practice. The most generally known method is the restrained installation where the distance between supports is small enough to prevent any noticeable sag in the cable. The alternative method is the unrestrained installation where the distance between supports should be great enough to ensure that there will be obvious sag in each span between supports.

17.7.6.4 SPACING OF SUPPORTS OF UNRESTRAINED CABLES

Large single core cables shall always be installed according to this method. Generally, single core cables with conductors exceeding a cross sectional area of 185mm² should be supported at spacings in excess of 2m since the sag between supports will safely accommodate any thermal expansion.

Reducing the spacing between the supports to 1,5m or less shall be avoided at all costs, as expansion cannot be taken up by a change of sag and chances of sheath failure become considerable.

17.7.6.5 SPACING OF SUPPORTS OF RESTRAINED CABLES

Additional cleats shall be installed at each bend or offset in the cable run. The maximum distance between supports or cleats for multi-core control cables shall be 20 times the outside diameter of the cable with a maximum spacing of 550mm for unarmoured cables and 30 times the outside diameter of the cable with a maximum spacing of 900mm for armoured cables. Spacing of supports for cables for high voltage lighting shall be in accordance with Table 8 of SANS 10142. A minimum of 20mm ventilation clearance shall be maintained between cables and the wall to which they are cleated.

17.7.7 GROUPING AND SPACING OF CABLES IN BUILDINGS AND STRUCTURES

17.7.7.1 SPACING CORRECTION FACTORS

Cables shall as a rule be spaced two cable diameters apart, for which no grouping correction factor need be applied.

17.7.7.2 CABLES ON DIFFERENT LEVELS

Where parallel cable runs are installed at different levels (e.g. on parallel cable trays) and where the spacing of the layers is not specified, a minimum spacing of 300mm shall be maintained.

17.7.7.3 SINGLE CORE CABLES

Where single core cables are installed along a three-phase circuit, the cables shall be installed in trefoil formation and bound together at 300mm intervals.

17.7.7.4 HIGH VOLTAGE CABLES

High voltage cables shall be separated from other cables and services throughout the installation and shall as far as possible be installed in separate floor trenches, pipes or metal channels. Where this is not feasible a minimum spacing of 500 mm shall be maintained.

17.7.7.5 CABLES FOR OTHER SERVICES

Cables for telephones, communication systems and other low voltage systems (less than 50 V) shall be separated from power cables. In building ducts a physical barrier shall be provided between power cables and cables for other services. Where armoured cables are used for such other services, they shall be installed on separate cable trays or shall otherwise be at least 1m away from power cables. Where unarmoured cables are used for these other services, they shall be installed in separate conduits or metal channels.

TABLE 1: MAXIMUM SPACING OF SUPPORTS FOR RESTRAINED CABLES

Cross-Sectional Area of Cable Conductors (mm ²)	MAXIMUM SPACING OF SUPPORTS (CLEATS) (mm) FOR RESTRAINED CABLES			
	Wire Armoured Cables		Other than Wire Armoured Cables and Unarmoured Cables	
	Horizontal Cable Routes	Vertical Cable Routes	Horizontal Cable Routes	Vertical Cable Routes
1,5	450	750	300	400
2,5	450	750	300	400
4,0	600	750	300	400
6,0	600	750	300	400
10,0	750	900	400	450
16,0	750	1000	400	550
25,0	900	1000	450	550
35,0	900	1000	450	550
Bigger than 35,0	900	1000	450	550

For larger cables the spacing shall be 10 x outside diameter of the cable.

17.7.8 TERMINATION AND JOINTING OF CABLES

17.7.8.1 GENERAL

- 1 Cable ends shall be terminated with glands or in cable boxes with the associated accessories such as clamps, shrouds, etc. complying in all respects with the Employer's Agent's Representatives instructions.
- 2 Connection of cables to switchgear shall always be effected in such a way that the various phases, seen from the front of the switchgear will be in the following positions:

No. 1 conductor: left (red) (A)
No. 2 conductor: centre (white) (B)
No. 3 conductor: right (blue) (C)
- 3 Exposed armouring shall be covered with bitumen-base paint.
- 4 All cable ends shall be supplied with the necessary earth connection.
- 5 A channel or other approved means of support shall be provided to remove mechanical stress from the glands.
- 6 Cable cores shall be marked with heat-shrunk sleeves where necessary to identify the phases. Refer to SANS 10142.
- 7 The current-carrying capacity and breakdown voltage of the cable end shall be the same as for the complete cable.
- 8 Cables shall be terminated in accordance with the recommendations laid down by the manufacturers of the cables and glands employed.

17.7.8.2 TERMINATION OF PVC INSULATED CABLES

- 1 Cable ends shall be terminated by means of adjustable glands.
- 2 The glands shall be fitted in accordance with the cable and gland manufacturers instructions.
- 3 The correct size and type of gland shall be used for the particular cable and application.

17.7.8.3 CONNECTION OF CABLE CONDUCTORS

- 1 Suitable lugs shall be used, preferably solidly sweated to the cable conductor ends. Lugs may be crimped, using mechanical or pneumatic tools designed for this purpose, on condition that evidence is submitted that the method used complies with the performance requirements of BS 4579, Part 1 : "COMPRESSION JOINTS IN COPPER".
- 2 Contact surfaces shall be thoroughly cleaned and smoothed and fixing bolts shall match the hole size of the lug.
- 3 Cables that are connected to clamp type terminals where the clamping screws are not in direct contact with the conductor, need not be lugged but the correct terminal size shall be used.
- 4 Ferrules shall be used as far as possible where cable conductors are connected directly to equipment with screws against the conductor strands.

- 5 When cutting away insulation from cable conductors to fit into lugs, care shall be taken that no strands are left exposed. Under no circumstances may any of the conductor strands be cut away to fit into lugs.

17.7.8.4 JOINTS

- 1 Joints in cable runs will not be allowed unless specified in the Detail Technical Specification or authorised by the Employer's Agent's Representative.
- 2 Jointing shall be carried out strictly in accordance with the manufacturer's instructions and by personnel competent in jointing the types of cables used.
- 3 During outdoor jointing operations, the joint bays shall be adequately covered by tents of waterproof material suitably supported. Where necessary a trench shall be excavated around the bay to prevent the ingress of moisture. The sides of the hole shall be draped with small tarpaulin or plastic sheeting to prevent loose earth from falling in during jointing operations.
- 4 The joint shall not impair the anti-electrolysis characteristics of the cable.
- 5 The Contractor shall notify the Employer's Agent's Representative timeously of the day on which jointing is to be carried out in order that an inspection may be arranged if so required. Any cable joint not inspected by the Employer's Agent's Representative because of insufficient notice being given, shall be opened for inspection and redone at the discretion of the Employer's Agent's Representative at the cost of the contractor.
- 6 LV cable joints shall be of the epoxy-resin type.
- 7 Joints shall be fully water and air tight and shall be free of voids and air pockets.
- 8 The crossing of cores in joints will not be permitted under any circumstances.

17.7.9 TESTING

- 1 Each cable shall be tested after installation in accordance SANS 1507 (up to 1 kV) and SANS 97 (up to 11 kV) as well as the requirements of the Local and Supply Authorities.
- 2 LV Cables shall be tested by means of a suitable megger at 1 kV and the insulation resistance shall be tabulated and certified.

TABLE 2

Cable Rating (kV)	TEST VOLTAGE (Applied for 15 minutes) (kV)				
	Paper-insulated cables				XLPE- insulated cables
6,6 11	Between conductors		Conductors to sheath		Conductors to screen
	AC (r.m.s)	DC	AC (r.m.s)	DC	DC
	12 20	18 30	12 20	18 30	11 18

High Voltage test with DC to 2kV for 1 minute only. Discharge cable slowly via discharge stick (1 minute). Clamp all conductors to earth for 24 hours.

- 3 HV Cables shall be high voltage tested in accordance with Table 2 and the exact leakage current shall be tabulated and certified.
- 4 The Contractor shall make all arrangements, pay all fees and provide all equipment for these tests. The cost of testing shall have been included in the tender price.
- 5 The Contractor shall notify the Employer's Agent's Representative timeously so that a he/she may witness the tests.
- 6 On completion of the tests on any cable, the Contractor shall without delay, submit three copies of the certified Test Reports to the Employer's Agent's Representative.

17.7.10 MEASUREMENTS

- 1 All measurements for payments shall be made jointly by the Employer's Agent's Representative and the Contractor and the Contractor shall obtain the signature of the Employer's Agent's Representative including approval of such measurements.
- 2 No allowance shall be made for the breaking away of the trench sides, other earth movements or for trenches excavated in excess of the stipulated dimensions.
- 3 The classification shall be as follows:

Very hard rock shall mean rock that can only be excavated by means of explosives.

Hard rock shall mean granite, quartzitic sandstone, slate and rock of similar or greater hardness, solid shale and boulders in general requiring the use of jack hammers and other mechanical means of excavations.

Soft rock and earth shall mean rock and earth that can be loosened and removed by hand-pick and shovel.
- 4 Where very hard rock and hard rock are encountered, the prior approval of the Employer's Agent's Representative shall be obtained before proceeding with the excavation. This requirement is stipulated in order to afford the Employer's Agent's Representative the opportunity to determine whether an alternative cable route is justified.
- 5 All cable lengths indicated in the Detail Technical Specification and/or shown in the cable route drawings shall be regarded as estimates and are given for tendering purposes only. The successful tenderer shall measure actual cable lengths on site before ordering.
- 6 The final price for the supply and installation of all cables will be adjusted, on the basis of the actual lengths of installed cables, in accordance with the unit rates quoted at the time of tendering. Cable lengths shall be measured on site to the nearest 500mm for this purpose and surplus cable will not be paid for.

17.7.11 COMPLETION

- 1 The Department reserves the right to inspect the installation at any stage during the course of construction. Such inspections will however not deem the portions inspected as being complete or accepted and the Contractor shall remain responsible for completing the installation fully in accordance with the Contract Documents.

- 2 The Contractor shall carry out a final "as built" survey of the cable routes and present to the Department "as built" route plans of the complete installation. The following information shall be reflected on the plans or submitted as separate schedules with the plans:
 - (a) Overall length of each cable.
 - (b) Locations of all joints (if any) in relation to permanent reference points. Dimensions shall be shown and the method of triangulation i.e. two dimensions to each joint, shall be used.
 - (c) Identification of each cable.
- 3 The works will be deemed to be incomplete until all tests have been conducted successfully and all "as built" drawings and schedules have been handed to the Department.

17.8 INSTALLATION OF LIGHT SWITCHES AND SOCKET-OUTLETS

17.8.1 GENERAL

17.8.1.1 STANDARDS

Light switches and socket outlets shall comply with the Department's quality specification for "LIGHT SWITCHES", Section 10 and UNSWITCHED AND SWITCHED SOCKET OUTLETS", Section 11. Surface or flush mounted boxes and cover plates, complying with the Department's quality specification for "CONDUIT AND CONDUIT ACCESSORIES", Section 1, shall be provided.

17.8.1.2 POSITION OF OUTLETS

Switches and socket-outlets shall be accurately positioned in accordance with the drawings. It is the Contractor's responsibility to ensure that all outlets are installed level and square, at the correct height from the floor and at the correct position relative to building lines and equipment positions as specified. It is the Contractor's responsibility to determine the correct final floor level and ceiling level in conjunction with the Main Contractor.

17.8.1.3 COVER PLATES

All switches and socket-outlets shall be fitted with standard metal cover plates. The colour of cover plates shall be as specified or shall otherwise match the surrounding finishes as closely as possible. Unless specified to the contrary, ivory cover plates shall be installed on painted walls. Cover plates in the same area shall have the same colour. Flush mounted cover plates shall overlap the draw-box and edges of the recess. Cover plates shall under no circumstances be cut unless authorised by the Department.

17.8.1.4 ESCUTCHEON PLATES

Where flush mounted switches or socket-outlets are installed in special wall finishes e.g. wood or board panels, acoustic tiles or other cladding, etc. and where the wall finishes must be cut to accommodate the switch, it may be necessary to fix an escutcheon plate to the wall to cover the cut-outs. The escutcheon plate shall fit closely around the outlet boxes and shall be fixed independently of the boxes and cover plates. Bevelled cover plates shall be fixed to the outlet boxes and shall fit firmly against the escutcheon plate.

17.8.1.5 APPEARANCE

The sides of adjacent switches, plugs, push-buttons etc. shall be parallel or perpendicular to each other and uniformly spaced. A common escutcheon plate shall be placed around flush mounted outlets and accessories where the standard cover plates do not cover the cut-outs in the finishes.

17.8.1.6 DEEP BOXES

Where switch or socket-outlet boxes have been set deep, spiral type steel wire spacers shall be used to fix the yoke of the switch or socket.

17.8.2 INSTALLATION OF SOCKET OUTLETS

17.8.2.1 MOUNTING HEIGHT

Unless specified to the contrary, socket-outlets shall be installed at the following heights above finished floor level, measured to the centre of the outlet:

Flush mounted in general:		300mm
Showrooms, shops, servant's quarters:	1,4m	
Domestic kitchens, tea kitchens:	1,05m	
Commercial kitchens:		1,4m
Factories, workshops, garages:	1,4m	

17.8.2.2 WALLS

In cases where socket-outlets must be mounted at a nominal height of 300mm and where the lower portion of the wall consists of face bricks and the upper portion is plastered, the outlets shall be installed in the plastered portion of the wall. If however the plastered portion of the wall commences 500mm or more above floor level the outlets shall be installed in the face bricks. Where a wall has different surface finishes the outlets shall be installed within the same finish and not in the dividing lines between the different wall finishes. All outlets shall be installed at least 150mm away from door frames.

17.8.3 INSTALLATION OF LIGHT SWITCHES

17.8.3.1 MOUNTING

Light switches shall be installed 1,4m above finished floor level unless specified to the contrary. Mounting heights given shall be measured from the finished floor level to the centre of the switch. All single switches shall be installed with the long side of the toggle vertical.

17.8.3.2 DOORS

Unless specified to the contrary, switches adjacent to doors shall be installed on the side containing the lock. If the position of the lock is not shown on the drawings, the position shall be verified before the switch-box is installed. Switch boxes in brick or concrete walls shall be installed 150mm from the door frame. Light switches installed in partitions or door frames shall be of the type designed for that purpose.

17.8.3.3 WALLS

Where the lower portion of a wall is face brick and the upper portion plastered, light switches shall be installed wholly in the plaster provided that the lower edge of the plaster is not higher than 1,6m above the finished floor level. In general, where different wall finishes are used in

the same area. Switches shall be installed within the same finish and not on the dividing lines between finishes.

17.8.3.4 PARTITIONS

Light switches installed in partitions shall preferably be of the type designed to be accommodated in the partition construction. Switches installed in the metal supports do not require switch boxes. Switches may not be flush mounted in partition walls without switch boxes.

17.8.3.5 WATERTIGHT SWITCHES

Switches that are exposed to the weather or are installed in damp areas, shall be of the watertight type.

17.8.3.5 MULTIPLE SWITCHES

Where several switches are required in one position, multi-lever switches in a common switch box shall be provided wherever possible. All circuits wired into this box shall be on the same phase in order that voltages in excess of 250 V are not present in the box. Where it is not possible or practical to do this, barriers shall be installed and a label shall be prominently displayed within the box stating that voltages in excess of 250 V are present.

17.9 PHOTO ELECTRIC DAYLIGHT SENSITIVE SWITCH FOR OUTSIDE LIGHTING

17.9.1 INSTALLATION

- 1 The outside lighting of each individual building i.e. light circuits marked "T" on the drawings, shall be controlled by photo-electric daylight sensitive switches.
- 2 The positions of the switches as indicated on the drawings are provisional and the exact positions shall be confirmed with the Employer's Agent's Representative on site.
- 3 Individual outside lighting circuits on a building may be connected directly to the daylight sensitive switch.
- 4 Where two or more lighting circuits are to be controlled by a single daylight sensitive switch, a contactor actuated by the unit shall be provided in the switchboard.
- 5 A by-pass switch enabling the lights to be turned on at any time, shall be provided.

17.9.2 CONSTRUCTION

- 1 The unit shall comprise a photo cell, thermal actuator and change-over switch. The cover of the unit shall be manufactured from a tough, durable material providing protection against tampering. The cover shall have good weathering properties. It shall be ultraviolet-resistant and shall not deteriorate when exposed to sunlight for prolonged periods.
- 2 The unit shall be of the wall mounting type and shall be supplied complete with a suitable bracket.
- 3 The operational level shall be factory preset for "ON" at a light level of approximately 54 lux and "OFF" at approximately 108 lux. Voltage variations shall not materially affect the operational levels.

- 4 A time delay of not less than 15 seconds shall be provided to prevent the unit from functioning due to short period changes in illumination.
- 5 The unit shall be effectively safeguarded against voltage surges by means of a suitable surge protector which shall preferably form an integral part of the unit.

17.10 INSTALLATION OF LUMINAIRES

17.10.1 POSITIONS

The mounting positions of luminaries shall be verified on site. All luminaries shall be placed symmetrically with respect to ceiling panels, battens, beams, columns or other architectural features of the space unless otherwise indicated. The layout as shown in the Documents shall generally be adhered to but any discrepancies or clashes with structural or other features must be referred to the Department, before commencing erection of the installation.

17.10.2 COVER PLATES

Cover plates shall be fitted over all draw-boxes and outlets intended for luminaries that are not covered by the luminaries canopy, lamp-holder, ceiling rose or similar accessories.

17.10.3 FIXING TO DRAW BOXES

Where an outlet box or draw-box provides the necessary support for some luminaries, all luminaries with the exception of fluorescent luminaries mounted against ceilings, shall be fixed directly to the box. Fluorescent luminaries and luminaries with a mass in excess of 10kg shall however be suspended independently of the outlet box.

17.10.4 HANGERS AND SUPPORTS

Where provision has not been made for the fixing of luminaries, the Contractor shall supply the necessary supports, hangers, conduit extensions, angle brackets or any other fixing method approved by the Department.

17.10.5 SUSPENDED LUMINAIRES

The necessary hangers shall be provided where luminaries which are of the non-suspension type have to be fixed below false ceilings or roof slabs. The use of 20mm conduits fixed to the roof slab or ceiling is preferred. Provision shall be made for adjustments to enable the levelling of luminaries. Suspended conduits shall be fixed to the ceiling by means of screwed dome lids, bolts and nuts. Ball-and-spigot type dome lids shall be used where conduit lengths exceed 600mm. Wiring shall be installed in the conduit hangers.

17.10.6 SUSPENDED WIRING CHANNELS

Luminaries (especially fluorescent luminaries) may also be suspended from ceilings by means of suspended metal channels. The metal channel may be supported by conduits or threaded rods. Should metal rods be utilised, these shall be screwed to anchor bolts fixed in the roof slab. Wiring shall either be installed in conduits fixed to the metal channel or in the metal channels and covered with a suitable cover plate. Purpose-made clamps shall be used to fix the luminaries to the cable channel.

17.10.7 CEILING BATTENS

Where wooden blocks are used to suspend luminaries, ceiling battens shall not be cut. The wooden blocks shall be cut to fit around battens and shall be screwed to the ceiling. Battens

may however be cut where fluorescent or incandescent luminaries with metal canopies have to be installed against a false ceiling.

17.10.8 GLASS-BOWL LUMINAIRES

Unless specified to the contrary, suspended glass-bowl luminaries shall be installed with the underside at least 2,1 m above finished floor level.

17.10.9 FLUORESCENT LUMINAIRES FIXED TO CONCRETE SLABS

Fluorescent luminaries to be installed directly against concrete slabs or walls shall be securely fixed to the outlet box and at two additional points. Shot-fired fixings are not acceptable. Where approved, fluorescent luminaries may be installed against metal wiring channels in which the wiring is housed. The channel fixing may in this case be shot-fired. Purpose-made fluorescent fixing adaptors shall be used to fix luminaries to cable channels.

17.10.10 FLUORESCENT LUMINAIRES FIXED TO CEILINGS

- 1 In all cases where luminaries are fixed to false ceilings, the Contractor shall ensure that the ceiling is capable of carrying the weight of the luminaries before commencing installation. Should any doubt exist in this regard, the matter shall be referred to the Employer's Agent's Representative.
- 2 In cases where the weight of the luminaire is not carried by the ceiling but by a support or other suspension method, provision shall be made to prevent relative movement between the ceiling and luminaire, ceiling rose or connection point.
- 3 Surface mounted fluorescent luminaries shall fit firmly against the ceiling branderling without leaving gaps between luminaire and ceiling. The luminaire shall be fixed directly to the ceiling by means of brass plated round-head wood screws and washers.
- 4 In the case of tiled ceilings with exposed or concealed T-section supports, surface mounted luminaries shall be fixed only to the tiles by means of butterfly screws or bolts with nuts and washers. The tiles shall be suitably reinforced.
- 5 Luminaries may alternatively be fixed to metal cross-pieces resting in the ceiling tees.
- 6 Drilling of holes in ceiling tees to support luminaries will not be allowed.
- 7 Luminaries shall be fixed in neat relation to the ceiling lay-out.

17.10.11 CONTINUOUS ROWS OF LUMINAIRES

In cases where fluorescent luminaries are installed in tandem, only one connection outlet need be supplied per circuit. All luminaries shall be coupled to one another by means of nipples or brass bushes and locknuts to ensure that wiring is not exposed and that earth continuity is maintained. Luminaries on the same circuit may be wired through the channel formed by the luminaire bodies. In this case silicon-rubber insulated conductors shall be used and internal connections shall be made at porcelain terminal blocks. "SCREW IT" or similar connectors may only be used if prior permission is obtained from the Department. The wiring for any other circuits or outlets, even though these may be in the same row, may not be installed through the luminaire bodies. The Contractor shall ensure that continuous rows are straight and parallel to the relevant building lines.

17.10.12 RECESSED LUMINAIRES

- 1 Where recessed luminaries are specified, the Contractor shall maintain close liaison with the ceiling Contractor. In the case of tiled ceilings, the luminaries shall preferably

be installed while the metal supports are being installed and before the tiles are placed in position. The Electrical Contractor shall be responsible for the co-ordination of the cutting of ceiling tiles with the other contractors concerned.

- 2 All mounting rings and other accessories shall fit closely into cut-outs to ensure a proper finish.
- 3 In all false ceilings where wiring channels are used, recessed luminaires shall be connected to the wiring channels by means of unswitched 5 A socket-outlets.
- 4 The following requirements shall be adhered to:
 - (a) Socket outlets used shall be of 5 A minimum rating.
 - (b) The connector cord attached to the luminaire may not exceed 3m in length and shall consist of 1,5mm² minimum, 3-core, PVC-insulated flexible cord.
 - (c) The 5A socket-outlets shall be positioned such that they are not more than 600mm above the false ceiling.

17.10.13 SPECIAL CEILINGS

In cases where special ceilings e.g. aluminium strips, decorative glass, metal leaves, etc. are to be installed, the Contractor and the Manufacturer of the ceiling shall agree upon the method of fixing of luminaires in the ceiling.

17.10.14 BULKHEAD LUMINAIRES

Surface mounted bulkhead luminaires shall not be screwed directly to conduit ends. The conduit shall terminate in a round draw-box at the top or rear of the luminaire. The PVC-insulated conductors shall terminate in a porcelain terminal strip in the draw-box. Silicon-rubber-insulated conductors shall be installed from the terminal strip to the luminaire lamp-holder. "SCREW-IT" or similar connectors may only be used if prior permission is obtained from the Department.

17.10.15 TYPE OF CONDUCTOR

PVC-insulated conductors, unless protected by an approved heat-resistant sheathing, shall not be used where the temperature of the insulation is likely to exceed 70°C. In unventilated luminaires or luminaires capable of housing incandescent lamps over 60W, the interconnecting wiring from the lamp-holder to the circuit wiring shall consist of silicon-rubber insulated conductors. Silicon-rubber insulated conductors shall be used exclusively in the case of high bay fittings. Refer also to the provisions of SANS 10142.

17.10.16 WIRING OF LAMPHOLDERS

The central terminal of Edison Screw (E.S.-type) LAMP-HOLDERS shall be connected to the phase conductor and the screwed housing to the neutral conductor.

17.10.17 HIGH BAY LUMINAIRES

- 1 High bay luminaires shall be securely suspended from the roof structure.
- 2 The luminaires may be fixed to suspended wiring channels containing the wiring on condition that:
 - (a) rigid channels with a maximum width of 42 mm be used,
 - (b) the channels are supported at intervals that will prevent sag or warp and

- (c) the channels are large enough to accommodate the wiring.
- 3 Luminaries may be suspended from metal roof trusses with the aid of "CADDY" or similar fasteners.
- 4 Luminaries shall preferably be connected to unswitched 5A socket outlets. Silicon-rubber insulated flexible cord shall be used exclusively to connect the luminaire to the outlet.
- 5 A safety chain to keep the luminaire from falling when loosened shall be provided.

17.11 CONNECTIONS TO EQUIPMENT

17.11.1 GENERAL

This section covers the final electrical connections to switchboards and various equipment in general electrical installations under normal environmental conditions for system voltages up to 600 V.

17.11.2 CONNECTIONS TO SWITCHBOARDS

17.11.2.1 CONDUIT ENTRIES

- 1 Where sufficient space for conduit entries as well as adequate space for future conduit entries is available, conduits may be terminated directly on the switchboard.
- 2 Alternatively, conduits connected to switchboards shall terminate in a common fabricated sheet steel draw-box installed in the vicinity of the switchboard. In open roof spaces this draw-box shall be placed in a roof space of not less than 900mm clearance.
- 3 Lighting and socket-outlet circuits may be separately grouped in common conduits or metal ducts (trunking) from the distribution board to the draw-box. The drawbox shall be of sheet steel with a minimum thickness of 1,6mm and shall be fitted with a removable cover plate.

17.11.2.2 FLUSH MOUNTED SWITCHBOARDS

Where flush mounted switchboards are required, the recessed switchboard tray shall be built into the brick or concrete wall. All conduits from the floor or roof shall be fully recessed and shall be bonded directly to the tray by means of locknuts on both sides and the ends of the conduits fitted with a brass bush.

17.11.2.3 SURFACE MOUNTED SWITCHBOARDS

Where surface mounted switchboards are specified but where the conduits can be fully recessed, the conduit shall be connected to a recessed connection box installed behind the switchboard. An opening with the same dimensions as the connection box shall be cut in the back of the switchboard and fitted with a suitable grommet.

17.11.2.4 SPARE CONDUITS

Where conduits from a switchboard run into a false ceiling space above the board, a minimum of two 25mm and two 20mm spare conduits shall be installed into the ceiling space immediately above the board.

17.11.2.5 CABLE CONNECTIONS

- 1 Where underground cables are to be connected to switchboards, it shall be the responsibility of the Contractor to ensure that metal, earthenware, asbestos-cement or other approved sleeves are built in correctly to enable installation and connection of the cable to the switchboard.
- 2 PVC or pitch fibre sleeves are not acceptable.
- 3 Sleeves shall be installed with a fall from inside to outside of the building to facilitate drainage. The sleeves shall be sealed with a non-hardening compound after installation of the cables to render the installation vermin proof and waterproof.
- 4 A metal cable channel with removable metal cover plate shall be installed by the Contractor and shall extend from the switchboard to the floor or into the ceiling void as required. The channel shall coincide with the position of sleeves. The channel shall be flush mounted except in the case of surface mounted switchboards and then only with the permission of the Employer's Agent's Representative.
- 5 The cable channel shall be large enough to permit the installation of cable glands and future cables, particularly where spare sleeves have been provided.
- 6 The colour of the channel cover shall match that of the associated switchboard.

17.11.2.6 CABLE TRENCHES

Where cables in floor trenches have to be connected to wall mounted switchboards, approved sleeves or conduits shall be installed from the side of the trench to the bottom of the switchboard. These sleeves shall be positioned and fixed before the concrete is cast.

17.12 EARTHING

This section covers the earthing of electrical installations in buildings or other structures. The total earthing system of any electrical installation shall be in complete accordance with SANS 10142.

17.12.1 GENERAL RECOMMENDATIONS ON THE PRACTICAL INSTALLATION OF EARTH ELECTRODES

17.12.1.1 REQUIREMENTS OF AN EFFECTIVE EARTH

- 1 An effective earth must prevent dangerous over voltages arising between metallic structures, frames, supports or enclosures of electrical equipment and the ground during fault conditions.
- 2 An effective earth must be able to permit fault currents of sufficient magnitude to flow so as to operate protective devices to isolate the fault before damage can occur.
- 3 The ohmic resistance of an effective earth must be low enough to ensure that the step potential on the ground in the vicinity of the earthing point is within safe limits under fault conditions i.e. a voltage gradient not exceeding 40 V/m for fault durations exceeding 1s.

17.12.1.2 TYPES OF EARTH ELECTRODES

Three types of earth electrodes are suitable:

1 Trench Earths

Trench earths comprise a bare copper or galvanised iron conductor laid at a minimum of 800mm below ground level, usually when underground cables are installed. This type of earth electrode provides a relatively large contact area between electrode and surrounding ground, makes contact with a variety of types of soil and soils of varying moisture content en route and is economical to install.

2 Spike Earths

Spike earths comprise rods of bare copper, copper-coated steel, stainless steel or galvanised steel designed for the purpose of penetrating ground to depths of up to several metres. A low resistance earth may sometimes be obtained by driving multiple spikes at some distance from each other in order to provide parallel paths.

In hard or rocky ground, it is usually necessary to drill holes into which earth spikes are inserted and then packed with soft soil.

3 Foundation Earths

Foundation earths comprise bare copper or galvanised iron conductors laid under the foundations of buildings, miniature substations, distribution pillars, bases of wooden, concrete or steel poles and structures. Because soil under foundations usually retains moisture, foundation earths are located to take advantage of this favourable condition. Furthermore, they are economical to install.

17.12.1.3 MATERIALS FOR EARTH ELECTRODES

- 1 Bare copper, either in stranded, strip or rod form, is considered the most suitable general purpose material for earth electrodes. Its main disadvantage is its cost and susceptibility to theft.
- 2 Bare galvanised iron and steel, either in stranded, strip or rod form, has a satisfactory record of survival in non-aggressive soils and is more economical than copper.
- 3 Bare aluminium is unsuitable as electrode material.

17.12.1.4 CORROSION

Because galvanised ferrous metals corrode sacrificially to copper, galvanised iron and steel electrodes should not be buried in close proximity to bare copper.

17.12.2 TECHNICAL REQUIREMENTS OF NEUTRAL EARTHING

The following relevant aspects have been extracted from the "AMEU CODE OF PRACTICE FOR THE APPLICATION OF NEUTRAL EARTHING ON LOW VOLTAGE DISTRIBUTION SYSTEMS."

17.12.2.1 DISTRIBUTION SYSTEMS

Multiple Earthed Neutral (MEN) and Protective Multiple Earthing (PME) systems.

Distribution equipment associated with transformer substations that are either ground mounted or pole mounted and fed by underground cable or overhead line, with or without an earth continuity conductor, (ECC), should be installed, connected and earthed in accordance with the following requirements:

- (a) Where the resistance to earth of the HV equipment earth is 1 ohm or less, it is permissible to earth the LV neutral to the HV earth electrode.
- (b) Where the HV equipment earth exceeds 1 ohm the LV neutral shall be earthed at a minimum distance of 6m from the HV equipment earth (i.e. 6m from the HV electrode/s and also from any earthed metalwork connected thereto).
- (c) Notwithstanding the requirements of (a) above, where transformers are associated with HV overhead lines, it is considered good practice to separate the HV and LV earth electrodes. The minimum earth separation should be 6m or one LV span.
- (d) The overall resistance to earth of the neutral of an LV distributor or distribution system must not exceed 10 ohms.
- (e) The LV neutral may be connected to other supply neutrals, earth electrodes, cable sheaths and armouring and these connections used to obtain the required earthing value of 10 ohms or less specified in par. (d). above.
- (f) The neutral of underground and overhead LV distributors must be earthed at the remote ends of each distributor.
- (g) Where the overall resistance to earth of the neutral of the distribution system exceeds 10 OHMS, the neutral shall be earthed at intermediate positions on the distributor/s to reduce its resistance to earth to below this limit.
- (h) The cross-sectional area of the neutral of all LV distributors must not be less than that of a phase conductor.
- (i) No circuit-breakers, isolators, fuses, switches or removable links shall be installed in the neutral between the transformer star point and the remote end of any LV distributor or service connection.
- (j) All metallic sheathing and armouring of cables and all metalwork associated with meter cabinets, fuse pillars, etc., supporting or enclosing LV cables shall be bonded to the distributor neutral conductor.
- (k) Where a Separate Neutral Earth (SNE) cable is part of an MEN or PME system, the armouring and/or metallic sheath and any ECC shall be bonded to the neutral at the supply end of the cable.
- (l) To ensure the integrity of the neutral, it is recommended that all connections and joints on or to overhead line conductors be made by compression fittings or, alternatively double bolted connectors.
- (m) MEN or PME may be applied to any single LV distributor without alterations to other LV distributors supplied from the same transformer.

17.12.2.2 PROTECTIVE NEUTRAL BONDING (PNB) SYSTEM

Since the neutral is earthed at one point only, the question of multiple earthing does not arise and there is therefore no necessity to meet the MEN/PME technical requirements.

17.12.2.3 SERVICE CONNECTIONS

- 1 MEN System

The following conditions apply to consumers' service connections as well as service connections to traffic signals, road signs, street lighting and other power-consuming equipment installed in public places:

- (a) All service connections must be by means of cable with an insulated phase, an insulated neutral conductor and an ECC.
- (b) A single phase service connection comprises a live, a neutral and an ECC.
- (c) A polyphase service connection comprises two or three phase conductors, a neutral and an ECC.
- (d) The service neutral and ECC must be solidly and separately connected to the distributor neutral at the tee-off point.
- (e) The consumer's earthing lead is connected to the Supply Authority's earth terminal which is in turn connected to the ECC in the service cable at the consumer's supply point.
- (f) The neutral must not be connected to earth at the consumer's supply point.
- (g) If required by the Supply Authority, an earth electrode must be installed at the consumer's supply point.
- (h) In a service connection to traffic signals, street light and other power-consuming equipment installed in public places, such equipment is earthed to the ECC of the service connection.

2 PME System

- (a) All service connections must be by means of a cable with an insulated phase and an insulated neutral conductor.
- (b) A single phase service comprises a live conductor and a neutral.
- (c) A polyphase service connection comprises two or three phase conductors and a neutral.
- (d) The consumer's earthing lead is connected to the supplier's neutral and to a mandatory earth electrode at the consumer's supply point.
- (e) A label must be attached at the consumer's supply point on his premises indicating that the installation is part of a PME system.

Note: It is not recommended that the PME system be applied to supply traffic signals, street signs or other power-consuming equipment installed in public places, because the PME system is inherently unsafe under "broken-neutral" conditions.

17.12.3 EARTHING OF A GENERAL ELECTRICAL INSTALLATION

17.12.3.1 GENERAL

All earth conductors shall be stranded copper with or without green PVC insulation. All earth conductor sizes shall be determined in accordance with SANS 10142, par. 4.6 where the earth does not form an integral part of the cable.

17.12.3.2 SWITCHBOARDS

A separate earth connection shall be supplied between the earth busbar of the main switchboard and the earth busbar of every sub-switchboard. These connections shall consist of bare or insulated stranded copper conductors installed along the same routes as the supply cables or in the same conduit as the supply conductors. Alternatively, armoured cables with earth continuity conductors included in the armouring may be utilised.

17.12.3.3 SUB-CIRCUITS

The earth conductors of all sub-circuits shall be connected to the earth busbar in the supply switchboard in accordance with SANS 10142.

17.12.3.4 RING MAINS

Common earth conductors may be used where various circuits are installed in the same wiring channel in accordance with SANS 10142. In such instances the sizes of earth conductors shall be specifically approved by the Employer's Agent's Representative. Earth conductors for individual circuits branching from the ring main shall be connected to the common earth conductor with T-ferrules or soldered. The common earth shall not be broken.

17.12.3.5 CONNECTIONS

Under no circumstances shall connection points, bolts, screws, etc. used for earthing be utilised for any other purpose. It will be the responsibility of the Contractor to supply and fit earth terminals or clamps on equipment and materials that must be earthed where these are not provided. Unless earth conductors are connected to proper terminals, the ends shall be tinned and lugged. Lugs may be crimped, using mechanical or pneumatic tools designed for this purpose, on condition that evidence is submitted that the method used complies with the performance requirements of BS 4579, Part 1: "COMPRESSION JOINTS IN COPPER."

17.12.3.6 NON METALLIC CONDUIT

Where non-metallic conduit is specified or allowed, stranded copper earth conductors shall be installed in the conduits and fixed securely to all metal appliances and equipment, including switch boxes, socket-outlet boxes, draw-boxes, switchboards, luminaries, etc. The securing of earth conductors by means of self-threading screws will not be permitted.

17.12.3.7 FLEXIBLE CONDUIT

An earth conductor shall be installed in all non-metallic flexible conduit. This earth conductor shall not be installed external to the flexible conduit but within the conduit with the other conductors. The earth conductor shall be connected to the earth terminals at both ends of the circuit.

17.12.3.8 WATER PIPES

Metal cold water mains shall be bonded to the earth busbar in the Main Switchboard by solid 15 x 2mm copper strapping. All other hot and cold water pipes shall be connected by 12 x 0,8mm perforated or solid copper strapping (not conductors) to the nearest switchboard. The strapping shall be fixed to the pipe work by brass nuts and bolts and against walls be brass screws at 150mm centres. In all cases where metal water pipes, down pipes, flues, etc. are positioned within 1,6 m of switchboards, an earth connection consisting of copper strapping shall be installed between the pipe work and the board. In vertical building ducts accommodating both metal water pipes and electrical cables, all the pipes shall be earthed at each switchboard.

17.12.3.9 ROOFS

Where service connections consist of overhead conductors, all metal parts of roofs, gutters and down pipes shall be earthed. One bare 10mm² copper conductor shall be installed over the full length of the ceiling void, fixed to the top purlin and connected to the main earth conductor of each switchboard. The roof and gutters shall be connected at 15m intervals to this conductor by means of 12 x 0,8mm copper strapping (not conductors) and galvanised bolts and nuts. Self-tapping screws are not acceptable. Where service connections consist of underground supplies, the above requirements are not applicable.

17.13 INSPECTIONS, TESTING, COMMISSIONING AND HANDING OVER

17.13.1 PHYSICAL INSPECTION PROCEDURE

- 1 Once the Contractor has completed the installation, written notice shall be given to the Employer's Agent's Representative in order that a mutually acceptable date can be arranged for a joint inspection.
- 2 During the course of the inspection, the Employer's Agent's Representative will compile a list of items (if any) requiring further attention. A copy of this list will be provided to the Contractor who will have a period of 7 days in which to rectify the offending items of the installation.
- 3 The Contractor shall then provide written notice that he is ready for an inspection of the remedial work to the offending items.
- 4 This procedure will continue until the entire installation has been correctly completed to the satisfaction of the Employer's Agent's Representative.

17.13.2 TESTING AND OPERATIONAL INSPECTION PROCEDURE

- 1 In addition to the above the Contractor shall have the complete installation tested and approved by the local authorities where applicable.
- 2 Subsequent to the above testing and approval, the Contractor shall in the presence of the Employer's Agent's Representative test all circuits with respect to:
 - (a) Phase balance.
 - (b) Insulation level.
 - (c) Polarity.
- 3 Upon completion of the installation and within 3 months of the handover date, the Contractor shall provide and make available a recording voltmeter to record the voltage at three locations in the complex over a period of 48 hours each. These locations will be nominated by the Employer's Agent's Representative.

17.13.3 "AS BUILT" DRAWINGS

- 1 As each portion of the work is completed, the Contractor shall provide the Employer's Representative with as built drawings showing the exact location measured from fixed points of all cables, transmission lines, each outlet point, etc.

- 2 In addition a complete reticulation diagram showing all supply cables and switchboards shall be provided behind a plastic cover in the substation or adjacent to the Main Switchboard if not located in a substation.
- 3 The installation will not be regarded as complete until all of the above requirements listed in 1, 2 and 3 above have been met.

17.14 SCHEDULE OF MATERIALS

17.14.1 LOW VOLTAGE RETICULATION AND DISTRIBUTION

- 17.14.1.1 Supply, delivery and installation of PVC SWA ECC PVC type cables, with stranded copper conductors and earth continuity conductors (Installation rate to include for installation in wireways, trays, ducts, trenches, etc. and for the provision of flameproof labels) (Excavations measured elsewhere).

Electrical Sub-Contractor to calculate the size of the cable to be sufficient for all the electrical installation requirements.

18 m x 2-Phase 3 core cable

17.14.1.2 Low Voltage Earthing

Allow for the bonding of the electrical installation

17.14.1.3 Earth Spikes

Supply, delivery and installation of earth spikes including all fastening materials, lugs, etc.

17.14.1.4 Electrical Distribution Board

Allow for the supply, delivery to site, installation of flush mounted sub-electrical distribution board unit, incl. fixing goods & lockable hinged doors.

17.14.1.5 Switches

Supply, delivery to site, installation of two lever, two-way light switches, including outlet boxes, covers and surrounds mounted to brick walls.

Supply, delivery to site, installation of one lever, one-way light switch, including outlet boxes, covers and surrounds mounted to brick walls.

17.14.1.6 Luminaires

Supply, delivery to site, installation of Norland / JB 258 / C21 / ECG / Steel fluorescent luminaires fixed to roof structure, including all fixing materials and terminations.

58 W linear fluorescent, cool white, 26 mm spare lamps to be handed to the Client.

17.14.1.7 Socket Outlets

Supply, delivery to site, installation of 16 ampere, double socket outlet, including outlet box cover and surround, mounted to brick wall.

17.14.1.8 Earth Leakage Unit

Supply, delivery to site, installation of earth leakage unit, including wiring.

17.14.1.9 Circuit Breakers

Supply, delivery to site, installation of moulded case circuit breakers, including wiring to busbars / main circuit breaker:

One (1) for 2-each Socket Outlets

One (1) for 2-each Socket Outlets

Three (3) for Luminaires (One for each set of lights per side of the building, one for office and store room together)

17.14.1.10 Isolators

Supply, delivery to site, installation isolators, including covers and surrounds, mounted to outlet boxes as per requirement for electrical installation.

17.14.1.11 Insulated Wiring

Supply, delivery to site, installation of wiring, fixed onto steel structure with suitable securing / fastening material.

17.14.1.12 Excavations

Excavate for cable trenches, including temporary support for sides, keeping excavation dry, bedding material, backfilling and compaction to specification of trench size 800 mm (deep) x 600 mm (wide).

In earth or pickable ground

Soil requiring the use of pneumatic tools and aids

PC 17 MEASUREMENT AND PAYMENT

Item **Unit**

PC 17.1 Electrical design, drawings and material list Sum

The unit of measurement shall be the sum for the electrical design, drawings and material list for the complete installation.

The tendered rate shall be for the Registered Electrician / Electrical Engineer to do the detail design of the electrical installation, preparation of electrical installation drawings and the preparation of a detailed material list of materials to be used for the installation. The design, drawings and material list must be approved by the Employer’s Agent’s Representative before any electrical installation work can commence.

Item **Unit**

PC 17.2 Connection to ESKOM / Municipal electrical network Sum

The unit of measurement shall be the Sum for the Low Voltage electrical connection to the identified ESKOM / Municipal electrical network, including cabling and terminations of the installation.

The tendered rate for the supply, delivery and installation of low voltage PVC PVC SWA ECC PVC type cables, with stranded copper conductors and earth continuity conductors (Installation rate to include for installation in wireways, trays, ducts, trenches (including excavations), cable terminations with all fastening materials, glands, shrouds, lugs, insulating materials etc. and for the provision of flameproof labels).

Item	Unit
PC 17.3 Low voltage earthing	Sum

The unit of measurement shall be the sum total for the low voltage earthing.

The tendered rates for the low voltage earthing shall allow for for the bonding of the installation (Installation rate to include for all materials and labour).

Item	Unit
PC 17.4 Earth spikes	Number (No.)

The unit of measurement shall be the number of earth spikes installed.

The tendered rates for supply, delivery and installation of earth spikes (Installation rate to include for installation fastening materials, lugs, etc.).

Item	Unit
PC 17.5 Main-Electrical districution board	Sum

The unit of measurement shall be the sum for the complete main-electrical distribution board.

The tendered rate shall allow for the supply, delivery to site, installation of flush mounted unit, incl. fixing goods & lockable hinged doors, as specified in Project Specification and depicted on single line diagrams from the electrical installation designer including all circuit breakers, isolators and earth leakage as the design drawings.

Item	Unit
PC 17.6 Internal electrical wiring	Sum

The unit of measurement shall be the sum for the complete internal wiring installed.

The tendered rate shall be for supply, delivery and installation of PVC sheathed, PVC insulated multi-core wiring with stranded copper conductors i.e. "twin and earth", drawn into wireways, or laid onto cable tray with suitable securing / fastening.

Item	Unit
PC 17.7 Light switches	Number (No.)

The unit of measurement shall be the number of light switches installed.

The tendered rates for supply, delivery and installation of light switches, including covers and surrounds, mounted to outlet boxes.

Item	Unit
PC 17.8 Luminaries (light fittings)	Number (No.)

The unit of measurement shall be the number of light fittings installed.

The tendered rates for supply, delivery and installation of light fittings, either fixed to round conduit boxes cast into brickwork or conduit boxes supported to ceiling / roof structure or mounted in recessed

ceiling grid, including all fixing materials and terminations including covers and surrounds, mounted to outlet boxes.

Item	Unit
PC 17.9 Socket outlets	Number (No.)

The unit of measurement shall be the number of socket outlets installed.

The tendered rates for supply, delivery and installation of socket outlets, excluding outlet boxes, but including covers and surrounds, mounted to outlet boxes, power skirting, flush floor ducting and / or under-screed ducting.

Item	Unit
PC 17.10 "As-Built Drawings"	Sum

The unit of measurement shall be the sum for the complete As-Built Drawings.

The tendered rate shall be for provision to the Employer's Agent's Representative with as built drawings showing the exact location measured from fixed points of all cables, transmission lines, each outlet point, etc. In addition, a complete reticulation diagram showing all supply cables and switchboards shall be provided behind a plastic cover adjacent to the Main Switchboard. The installation will not be regarded as complete until all of the above requirements have been met.

18 SECTION 18: ROADSTONE SURFACING

INTERLOCKING CONCRETE ROADSTONE SURFACING

18.1 EXCAVATIONS

Excavations shall be deemed to be in “earth”, unless otherwise described.

18.2 PREPARATION OF FORMATION

18.2.1 DEFINITION:

The formation level is that level of material above which the specified cover of base-course material may exactly be accommodated. This level extends under the width of the driveway and parking area including where applicable curbing.

18.2.2 EXCAVATION AND FILL

The excavation and/or fill shall be carried out to such a depth that after compaction the specified cover can be exactly accommodated. Fill material shall be compacted in 150 mm layers to 100% Proctor Compaction. Only material from excavation, free of grass roots and other deleterious material shall be used for the grading of open areas. All surplus excavated material shall be disposed of as directed by the Employer’s Agent’s Representative.

18.2.3 REQUIREMENTS

The finished surface of the formation is to be tested for smoothness and accuracy of elevation. At no position shall the top of the formation be more than 3 mm above or 10 mm below the specified level and, when tested with a 4 m long straight edge, be more than 10 mm out of level. The area must be protected effectively against storm water by adequate drainage to prevent softening.

The formation must be approved by the Employer’s Agent’s Representative before construction of the base course, curbing or storm water drains is commenced.

18.3 SABUNGA BASE COURSE

18.3.1 G5 SABUNGA

Approved grade G5 Sabunga shall be used for the Base Course. The Contractor shall ensure that he is provided with a grading certificate from the supplier that the Sanbunga does comply with the minimum grading requirements for G5.

18.3.2 CONSTRUCTION

The underlying layers shall be approved by the Employer’s Agent’s Representative before any construction work is undertaken.

Sabunga shall be dumped in windrows such that when flattened out it will form a layer covering the driveway surface to the depth specified after compaction.

The material shall be thoroughly blade by means of a motor grader and shall be bladed from one side of the driveway or area to the other in successive cuts made to the full depth of the layer.

The sabunga shall be maintained at optimum moisture content during the placing process.

The sabunga shall be shaped and levelled off evenly, true to the required lines, grades and cross sections and to such thickness that, after compaction, the base shall conform to specified requirements.

18.3.3 COMPACTION

Immediately after spreading, initial rolling shall be carried out with pneumatic tyre rollers of not less than 15 tons' mass.

To avoid fines from being washed to the bottom of the layer, nor further application of additional water shall be allowed during the initial compaction.

After the whole surface have been covered at least three times, rolling from sides to centre, the layer shall be cut to the required grades and cross sections.

Rolling shall continue until all material displaced or loosened by cutting and shaping has been kneaded firmly into the layer.

Further rolling shall be carried out by means of 3-wheel tyred rollers of not less than 12 tons mass as soon as the layer has dried off sufficiently. Rolling is to be from the sides to the centre with half wheel laps.

18.3.4 REQUIREMENTS

The base course shall conform to the following requirements:

Compaction: 88% solid density.

Cross section: To within 10 mm.

Thickness: To within 10 mm.

Smoothness: Surface is to be free from any irregularities exceeding 5 mm measured with a 4 m long straight edge parallel with the centre line.

Wave of corrugations: Surface is to be entirely free of waves or corrugations.

18.4 INTERLOCKING CONCRETE ROADSTONES

After the base course has been approved and the storm water drains and curbing completed, the prepared base must be treated with a weed killer similar or equal to HYVAR X at the rate of 4 g/m².

Cover the road surface and parking area with a 300-micron plastic sheet (black). The plastic sheet shall be cut straight and square or to shape by using sharp instruments. All joints shall be minimum, lapped and sealed with pressure sensitive tape.

Spread a plus minus 45 mm thick loose layer of bedding sand (to compact to 25 mm). the sand shall be sharp and well graded, silt or clay content not exceeding 3%, with 85% or more passing a 2.36 mm sieve.

The sand must be levelled using straight edges or other suitable means. The sand surface must not be disturbed or walked upon before placing the blocks.

Approved, 80 mm thick, interlocking, 30 MPa concrete road stones with chamfered top edges are to be laid in a herringbone pattern and compacted with a plate vibrator until the desired line and level is achieved where after the sweeping of sand into the joints and additional passes of the plate vibrator are made until the joints are completely filled. The filling sand shall be finer than that used for bedding and should completely pass a 1.18 mm sieve, 90% or more being retained on a 0.075 mm sieve.

18.5 CONCRETE KERBING

All open edges of the concrete road stones shall be finished off with precast concrete kerbing of size as shown on the drawings.

PC 18 MEASUREMENT AND PAYMENT

Item	Unit
-------------	-------------

PC 18.1 Treatment of Base with weed killer	Square metre (m ²)
--	--------------------------------

The unit of measurement will be in square meter base area treated with a weed killer similar or equal to HYVAR X at the rate of 4 g/m².

The tender rate shall include the supply, delivery and storage of chemicals at site, all labour for the mixing, spraying/applying the weed killer onto the base in accordance with the manufacturer's specifications.

Item	Unit
-------------	-------------

PC 18.2 Damp proof membrane (black) 0,3 mm thick	Square metre (m ²)
--	--------------------------------

The unit of measurement will be in square meter (black) 0,3 mm thick damp proof membrane placed.

The tender rate shall include the supply, delivery and storage of all material. The rate shall include cutting, placing of all damp proof sheeting, sealing of joints and compensation for wastage as specified in drawings and specifications.

Item	Unit
-------------	-------------

PC 18.3 General filling from imported material (Sand)	cubic metre (m ³)
---	-------------------------------

The unit of measurement shall be the cubic metre for the imported selected sand filling material and deposited at 50 mm thickness, watered and consolidated to compacted layer not exceeding 25mm thick working course under road stones.

The tendered rates shall include full compensation for all material, labour and plant for the depositing and compaction of the imported filling material into the works.

Item	Unit
PC 18.4 Interlocking Concrete Road stone	Square metre (m ²)

The unit of measurement shall be the square meter of interlocking concrete road stone completed.

The tendered rates for all interlocking concrete road stone shall include full compensation for all labour and materials, the preparation of base course, the placing of the plastic waterproof membrane, the placing of the sand filler layer, the placing of road stones, the cutting of road stones, the compaction of road stones and filler layer, the sweeping of sand into the joints, protection of work against damage during construction.

Item	Unit
PC 18.5 Concrete kerbing	metre (m)

The unit of measurement shall be the running meter of concrete kerbing completed.

The tendered rates for all concrete curbing shall include full compensation for all labour and materials, the preparation of base course, the placing of concrete curbing, the cutting of concrete kerbing, the compaction around the curbing and protection of work against damage during construction.

19 SECTION 19: STOCK PROOF FENCES

19.1 SCOPE

This specification covers the dismantling of existing fences as directed by the engineer and the requirements for the erection of new 1.2m or 1.4m high stock fence consisting of barbed wire as indicated on the drawings or as directed by the engineer.

This section also covers the stacking of the fencing material of dismantled fences.

19.2 FENCING TOOLS

The contractor shall supply a set of fencing tools as identified in the Bill of Quantities that will be used for training the local community to repair fences. This set of tools will be part of the contract and handed over to the chairperson of the community. The quantity will be as specified in the bill of quantities.

19.3 APPROVAL OF MATERIALS AND TOOLS

The supplier/contractor shall provide the Department with a certificate from an accredited Testing Service Provider that the fencing material supplied complies with the required SANS codes as prescribed.

The Contractor shall inform the Employer's Agent in good time, to inspect and approve materials that will be used in the project before construction commence or on arrival of material from site:

Posts for use in the corners, straining and gate boxes of the fence,
Standards and droppers for use in the fence,
Wires, barbed wire, anchor wire and binding wire for use in the fence,
Mesh wire to close openings.
Fencing tools.

19.4 MATERIALS AND DIMENSIONS

19.4.1 CORNER-, STRAINING-, ANCHOR-, GATE POSTS AND BRACES

Corner-, Straining-, Anchor-, Gate Posts and Braces shall be wooden poles and of quality suitable for fencing and to the size indicated on the drawings.

Posts and Braces shall be treated and bearing the SANS mark. SANS 1288 (Copper-chrome arsenate treated timber) or SANS 05 (Creosote treated timber).

Corner-, Straining-, Anchor- and Gate Posts shall have a length of 2100mm for 1,2m high fence, or 2400mm for a 1,4m high fence and a top diameter of between 125 to 150mm.

Braces shall have a length of minimum 1800 mm and a top diameter of between 100 to 125 mm.

19.4.2 STANDARDS

Standards shall be Y-section iron standards that has a mass of 2,0 kg/m and total length of 1850mm, that is a total mass of 3,7 kg for an 1850 mm length standard. The standards shall be provided with notches and holes 50mm apart. Standards shall be according to ISCOR Specifications SPE 261.

19.4.3 DROPPERS

The dropper length shall be determined by the fence height as specified by the Engineer or as per drawing dimensions.

Droppers shall be the Ridgeback iron droppers that has a mass of 0,58 kg/m and total length of 1250mm or 1400mm. Droppers shall be according to ISCOR Specifications SPE 261, for a 1,2m or 1,4m high fence.

Or

Droppers shall be the Newcastle iron droppers that has a mass of 0,62 kg/m and total length of 1250mm or 1400 mm. Droppers shall be according to ISCOR Specifications SPE 261, for a 1,2m or 1,4m high fence.

Or

Droppers shall be Timber droppers that has a diameter of 32/50mm and total length of 1250mm or 1450mm. Droppers shall be according to SANS 457 – 3 or SANS 1288 specifications. The dropper length shall be determined by the fence height as specified by the Engineer or as per drawing dimensions.

19.4.4 WIRE

(i) Barbed wire

Barbed wire shall comply with the requirements of SANS 675 and shall be of the following type:

Mild-steel-grade fully or lightly galvanized zinc-coated double-strand uni-directional twist wire, each strand 2,00 mm in diameter, for use at any height above ground, as specified.

Barbs shall be manufactured from 1,6mm fully galvanized zinc-coated mild steel wire and shall be spaced at not more than 150 mm.

(ii) Smooth wire

The wire shall be Class A galvanized and comply with the requirements of SANS 675 and shall be of the type specified below:

Anchor wire shall be 4,00 mm diameter fully galvanized zinc-coated mild steel wire.

Tying wire shall be 2,00 mm diameter mild-steel fully galvanized zinc-coated wire for tying fencing wire to standards and droppers and 1,6 mm mild-steel fully galvanized zinc-coated wire for tying netting and mesh wire to the fencing wire.

19.4.5 WIRE NETTING

Wire netting shall be fully galvanized mild-steel wire with a minimum diameter of 1,8 mm, with 75 mm hexagonal mesh.

The width shall be as shown on the drawings.

19.4.6 GATES

Gates shall be manufactured to the dimensions and details shown on the drawings. Gates shall be manufactured of mild steel tubing having continuously welded seams.

The frame shall be of tubing of bore 42 mm and wall thickness of 2,0 mm in the case of main frame members, and of a bore 22 mm and wall thickness of 2,0 mm in the case of bracing members. The width of each gate shall be as shown on the drawings.

Gates shall be complete in every respect, including hinges, washers, bolts and locking chains attached to the gate.

Gates shall be painted with silver aluminium paint.

19.4.7 TIMBER POSTS FOR WIRE MATS

Timber posts for holding down wire mats where the fence crosses streams shall comply with the requirements of SANS 457.

19.4.8 MANUFACTURING TOLERANCES FOR WIRE

The actual diameter of wire supplied shall equal the specified diameter subject to the appropriate tolerance given in SANS 675.

19.5 CLEARING THE FENCE LINE

The fence line shall be cleared over a width of at least 1 m on each side of the centre line of the fence and surface irregularities shall be graded so that the fence will follow the general contour of the ground. Clearing the line shall include the removal of all trees, scrub, stumps, isolated boulders or stones and other obstructions which will interfere with the construction of the fence. Stumps within the cleared space shall be grubbed. The bottom of the fence shall be located at a uniform distance above the ground line in accordance with the requirements shown on the drawings. All material removed shall be burnt or disposed of in disused borrow pits.

All existing fences shall be dismantled and material suitable for re-use shall be coiled and stacked, including posts and wire and moved to a designated area indicated by the Employer's Agent.

19.6 CONSTRUCTION

19.6.1 POSTS

A post shall have no damaged marks on it and shall not be cut to length after it was treated with a preservative chemical or creosote.

19.6.2 BRACES

Braces shall have no damaged marks on it and shall not be cut to length after it was treated with a preservative chemical or creosote.

19.6.3 MEANS FOR ATTACHING FENCING WIRES TO POSTS, STANDARDS AND DROPPERS

At all straining posts at terminal points, gates, corners, bends and other specified positions, the fencing wire shall be securely wrapped twice around the post and secured against slipping by tying the end tightly around the wire by means of at least six snug tight twists.

Where high-tensile wire is used, two long twists may first be made followed by the six tight, snug twists around the post to prevent the wire from breaking at the first twist. When smooth

wire is used, the loose end shall preferably be bent over and hooked into the notch between the fencing wire and the first twist.

Splices in the fencing wire shall be permitted if made in the following manner with a splicing tool. The end of each wire at the splice shall be taken at least 75 mm past the splicing tool and wrapped snugly around the other wire by not less than six complete turns with the two separate wire ends being turned in opposite directions. After the splicing tool has been removed, the space left by it in the spliced wire shall be closed by pulling the wire ends together. Unused wire ends shall be cut close so as to leave a neat splice.

The gaps between gate posts and the adjacent straining posts shall be fenced off with short lengths of fencing wires.

All fencing wire shall be tied to the sides of standards or posts to prevent the wires from being displaced or becoming loose. The wire shall be carefully tensioned without sagging, and true to line, care being exercised not to tension the wire to such an extent that it will break, or that end, corner, straining or gate posts will be pulled out, or that it will be easily damaged during veld fires. A tension of 1,0 kN (kilo Newton) per wire shall be required as working stress. This stress will be determined seven days after erection.

Each strand of fencing wire shall be securely tied in the correct position hard up to each standard with soft galvanized tying wire. The tying wire for each strand shall pass through a hole or notch in the standard, while the ends of the tying wire shall be wound at least four times around the fencing wire to prevent it from moving in a vertical direction.

Droppers shall be tied to each fence wire with soft tying wire in the required position as specified for standards to prevent slippage in a vertical direction. The spacing of droppers between any two standards shall be uniform but shall never exceed 3m. Anchoring to structures shall be done as shown on the drawings.

19.6.4 UNROLLING AND TENSIONING OF FENCING WIRES

The bottom wire of the fence is stretched first between straining posts and serves as a guideline for the standards.

The standards are now set at the required distance using the bottom wire as a guideline. To ensure that the bottom wire is exactly on line, it is required that a temporarily post be placed in line halfway between the straining posts as a check.

The top wire is stretched next, followed by the second from the bottom, the second from the top, etc.

The wires are stretched by fastening the one end to one straining post by means of two turns around the post and the other end is pulled as tightly as possible by hand. The sling of the wire strainer is put around the straining post in a position a bit lower than the height of the wire. The wire is then gripped in the grippers of the strainer and stretched to the required tension (maximum of 1,0 kN but not less than 0,8kN). The wire is then cut, leaving sufficient length to go twice around the straining post with something extra for twisting on itself. The wire is then tied to the straining post and the strainer uncoupled.

19.6.5 GATES

Gates shall be of welded construction with all corners of the main frame members bended. Gates shall have at least two bracing members. All welds shall be continuous.

Gates shall be fitted with wire netting securely attached to each main frame member and bracing member by tie wires.

Two hinge bolts or hinge eyes similar in shape and construction shall be provided for each gate leaf and two nuts and two washers shall be supplied with each bolt. A positioning and supporting collar shall be welded to the hinge stile (See drawings). Each gate shall be provided with a hasp and staple, and a padlock.

19.6.6 CLOSING OPENINGS UNDER FENCES

At ditches, streams, drainage channels or other depressions where the fence cannot be erected so as to follow the general ground contour, contractor shall close the opening under the fence with horizontal barbed wires at 150 mm distances, stretched between additional posts or straining posts as shown on the drawings or directed by the engineer. In the case of vermin-proof fences the opening shall be covered with strips of wire netting or diamond mesh 1000 mm wide, fixed to the barbed wires.

In the case of larger streams where damming of debris against the fence would constitute a hazard, the opening below the bottom fencing wire shall be closed loose-hanging wire nets. For this purpose, additional straining posts shall be planted on both sides of the stream with a cable consisting of at least five strands of smooth fencing wire strands stretched between them. Onto this cable vertical strips of diamond mesh hanging down to ground level shall be fixed. The edges of the various strips of diamond mesh shall be fixed to each other so that the entire mat will be raised by water flowing underneath to leave a free stream area. These mats at streams shall be erected only on instructions by the engineer. If it should be necessary to keep the bottoms of the mats on the ground, the engineer may order that timber posts or pipes be fixed horizontally to the bottom ends of the diamond-mesh strips.

19.7 EXISTING FENCES

Where a new fence joins an existing fence whether in line or at an angle, the new fence shall be erected with a new straining post positioned at the terminal of the existing fence.

Existing fences that require be taking down or removing to a new location shall be dismantled. Material not required for re-erection or unsuitable for re-use shall be neatly stacked at approved locations in accordance with the Employer's instructions. Fencing wire and wire netting shall be stacked clear of the ground. Payment will be made only for fences removed in accordance with the written instruction of the engineer.

Where fences require moving, the contractor shall re-use all the material, declared to be suitable for this purpose by the engineer, plus such new material as may be required to put up the fence again to the standard specified for new fences. The engineer shall not be responsible for any delays or costs arising from the breaking of re-used wire during straining.

19.8 REQUIREMENTS FOR THE FENCE

19.8.1 DESIGN

19.8.1.1 GENERAL

The completed fence shall be plumb, taut, true to line and ground contour, with all posts, standards and stays firmly set. The fence shall be in a perfectly straight line from straining post to straining post, with all the standards standing in perfect alignment. Irrespective of the number and type of wire strands used, each shall be at a specific height above ground level, be parallel to the other and be well secured to each standard in such a manner that it cannot be shifted vertically. The height of the lower fencing wire above the ground at posts and standards shall not deviate by more than 25 mm from that shown on the drawings. Other fencing wires shall not deviate by more than 10 mm from their prescribed vertical positions.

The contractor shall, on completion of each section of fence, remove all cut-offs and other loose wire or netting so as not to create a hazard to grazing animals or a nuisance to the owners of the ground.

The straining-, corner- and gate posts shall be sturdy, be set vertically into the ground and be anchored. All the other posts, standards and droppers shall stand erect and maintain the same height above ground level. Straining posts shall not be far apart, but never be further apart than 250m.

Droppers shall be so spaced that the distance between the standards are equally divided. They shall stand erect and the wire strands shall be securely tied to them at the same spacing as on the standard.

19.8.1.2 SIZE OF FENCE

The height, from the ground level to the top of the fence, shall be the appropriate height of 1.2m or 1.4m as specified in the scope of works and on the drawings. The length of the fence shall be as specified by the Employer's Agent

19.8.1.3 FENCING WIRES

There shall be at least nine fencing wires at spacing as shown on the drawings. The type and combination of barbed and plain high tensile steel wire shall be as shown on the drawing or as directed by the Employer's Agent.

19.8.1.4 GATES

The number of gates and pedestrian gates shall be as specified by the Employer's Agent.

19.8.2 ERECTION

19.8.2.1 POSTS

Corner posts shall be provided at all corners and other changes in direction. Anchor posts shall be provided at acute variations in the level of the fence, and as supports for gates. On straight lengths of fencing, straining posts shall be spaced not more than 250 m apart.

19.8.2.2 STANDARDS AND DROPPERS

The closer the standards are together and the more droppers there are between them, the sturdier and efficient the fence, the purpose of the fence, circumstances and soil conditions will dictate what the best spacing for an efficient fence will be.

The following spacing of standards and droppers will apply for both boundary- and internal camp fences:

- a) Standards 12m apart with 3 droppers in between

19.8.2.3 GATE AND ANCHOR BOXES

Corner and Straining Boxes shall be a combination of two box anchors and therefore be provided with two braces, of 1 800 mm in length, shall be fixed to the corner post and anchors as shown on the drawings or as directed by the Employer's Agent. Gate Boxes shall have one brace, of 1 800 mm in length and shall be fixed to each post as shown on the drawings or as directed by the Employer's Agent.

19.8.2.4 FENCE WIRES

Fencing wires shall be parallel. Each fence wire shall be twisted at least two times around a straining post. The free end of the wire shall be twisted at least six times around the wire. The fencing wire shall be secured to each standard and dropper by a tie wire.

19.8.2.5 WIRE NETTING

The wire netting shall, after being suitably tensioned to ensure that the wire netting is straight in all directions, be attached by tie wires to the fence wires. The positions of attachment shall be as follows:

- 1) To the top fence wire as shown on the drawings that will hold the wire netting in position: at distances not more than 150 mm apart.
- 2) To the bottom fence wire: at distances not more 150 mm apart.
- 3) To the intermediate fence wires: at distances not more than 300 mm apart.

In addition, the wire netting shall be attached to each straining post by means of tie wires taken around the post at distances of 150 mm.

19.8.3 GATES

Gates shall be so erected that:

- a) There is a gap of not less than 25 mm and not more than 50 mm between the hinge stile(s) and the straining posts;
- b) There is clearance of not less than 50 mm and not more than 75 mm between the bottom horizontal frame member(s) and the ground; and
- c) When closed, there is a space of not more than 25 mm between the closing stile and the straining post in the case of single-leaf gates.

19.8.4 WORKMANSHIP

19.8.4.1 POSTS

All posts shall be rigid and sturdy, set well into the ground and be well anchored. The narrower a post fits into the hole, i.e. the less the fill round the side of the post, the greater the resistance of the post. The hole for a pole should not be of greater diameter than 250mm where it is planted directly into the soil. Soil must be carefully backfilled with soil in layers of 150 mm maximum thickness and well compacted. Under wet conditions, it is recommended that the hole be filled with drier soil which in turn is compacted better.

19.8.4.2 STANDARDS AND DROPPERS

All standards shall be driven into the ground to a minimum depth of 600 mm. Standards must be sturdy and preferably driven in the ground with a Post driver.

19.8.4.3 WIRES

Fence wires shall be taut, and securely fastened to the posts.

19.8.4.4 WIRE NETTING

The wire netting shall be sufficiently tensioned to ensure that the wire netting is uniform, and it shall be securely fastened.

19.8.4.5 GATES

Gates shall have no noticeable twist or sag. When the gates are closed, the closing stiles shall be parallel in the case of double-leaf gates, or the closing stile shall be parallel to the adjacent straining post in the case of single-leaf gates. Gates shall move freely on their hinges. Hasps and staples shall be in correct alignment and operate freely. In the case of double-leaf gates the drop bolts shall operate freely.

19.8.4.6 BRACES

All braces shall be secure to the posts with a 10 mm diameter iron rod hammered into a hole drilled specifically for that purpose and then secured with 4 mm diameter galvanized mild steel wired.

PC 19 MEASUREMENT AND PAYMENT

Item **Unit**

PC 19.1 Clearing the fence line, 2m wide strip. metre (m)

The unit of measurement for clearing the fence line shall be the metre of fence line measured along each fence line.

The tendered rate shall be in full compensation for clearing the fence line complete as specified in “**CLEARING THE FENCE LINE**”, including amongst others the removal of trees, stones, and other obstructions and the disposal of all waste material resulting from clearing operations, as may be directed.

The removal of trees and stumps with a girth exceeding 1 m shall be paid for as an extra over.

Item **Unit**

PC 19.2 Supply and construct new stock fence line. metre(m)

The unit of measurement for erecting the fence shall be the meter of fence line measured along each fence line.

The tendered rate and price paid shall be in full compensation for providing all standards, droppers, fence- and tie wire, wire netting including tying wire and staples for putting up the fence as specified and as shown on the drawings inclusive of all excavations and drilling required with pneumatic tools for holes for the standards or droppers

Item **Unit**

PC 19.3 Corner-, Straining- and Anchor Boxes. Number (No)

The unit of measurement for erecting Corner-, Straining- and Anchor Boxes shall be an extra-over for the number of anchor boxes within a fence line.

The tendered rate shall be in full compensation for provisioning all materials for the corner- and straining anchor, the brace(s), wire, for excavating and drilling with pneumatic tools of holes, for erecting the box anchors as specified and shown on the drawings, all complete as a unit.

Item	Unit
PC 19.4 Gate Boxes.	Number (No)

The unit of measurement for erecting Gate Boxes shall be an extra-over for the number of gate boxes within a fence line.

The tendered rate shall be in full compensation for provisioning all materials for the gate boxes, the brace(s), wire, for excavating and drilling with pneumatic tools of holes, for erecting the boxes as specified and shown on the drawings, all complete as a unit.

Item	Unit
PC 19.5 Gates (size and type indicated).	Number (No)

The unit of measurement shall be an extra-over for the number of new gates erected.

The tendered rates shall include full compensation for all material (steel pipes, wire and wire netting), manufacturing of gates to specifications and sizes, zinc-coating, hinges and bolts, hasps and padlocks and for installing the gates complete as specified and as shown on the drawings.

Item	Unit
PC 19.6 Dismantling existing fence.	metre (m)

The unit of measurement for the dismantling of existing fences shall be metre of fence taken down and dismantled on the instruction of the Employer's Agent.

The tendered rates shall include full compensation for taking down existing fences and gates, coiling wires, rolling netting into rolls, transporting the material to designated sites and stacking the material.

Item	Unit
PC 19.7 Closing of openings through dongas and rivers.	Square metre (m ²)

The unit of measurement shall be an extra-over for the square meter of wire netting, the quantity of which shall be calculated according to the prescribed width and the length of the opening as instructed by the Employer's Agent to be closed.

The tendered rates shall include full compensation for provisioning of all material, providing all labour, putting up the wire netting as required by the Employer's Agent or as stipulated in the drawings and to ensure that the openings are stock proof.

Item	Unit
PC 19.8 Posts fixed horizontally to the bottom of wire mesh.	metre (m)

(a) Timber posts (150mm diameter)

The unit of measurement shall be an extra-over for the metre of post installed.

The tendered rate shall include full compensation for procuring, furnishing and fixing the posts, complete as specified and as shown on the drawings.

Item

Unit

PC 19.9 Fencing Tools for maintenance. Number (No)

The unit of measurement for the fencing tools shall be for the number of items as specified in Standard Drawing as attached to the tender document.

20 SECTION 20: LARGE STOCK PRE-FABRICATED ANIMAL HANDLING FACILITIES

20.1 SCOPE

This specification covers the supply and delivery of pre-fabricated cattle handling facilities.

20.2 CATTLE CRUSH

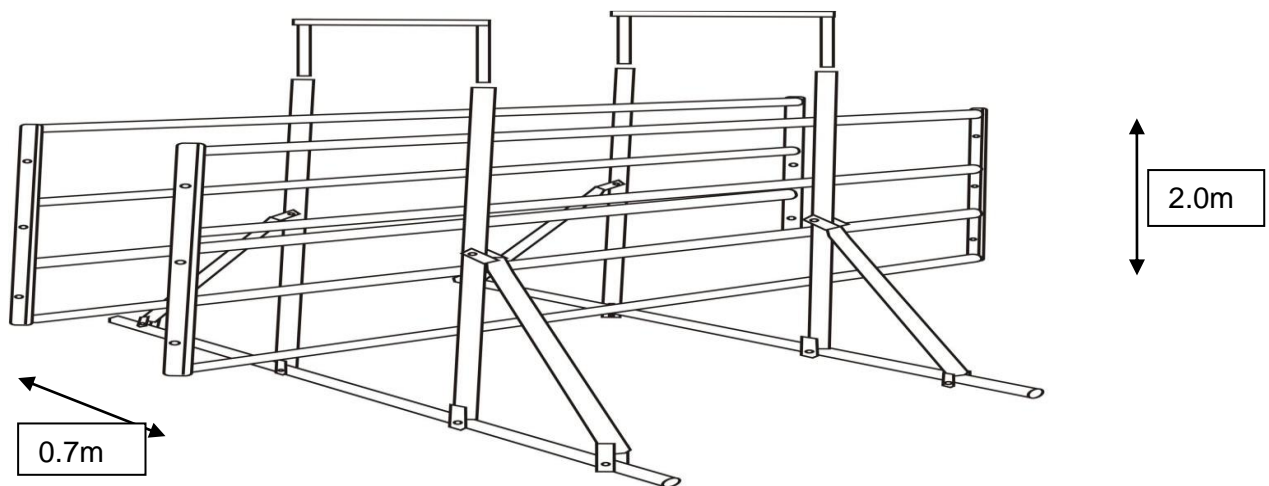

- Crush sections shall be Taltec or similar approved.
- The length and width of the cattle crush shall be at least 3m and 2m respectively.
- Tube diameter shall be 40mm x 3mm thick.
- Complete assembled 3m section with foot pieces, struts, M12 bolts and nuts
- Painted with 2 layers of grey primer and 1 layer of olive green enamel paint.

20.3 HEAVY DUTY NECK- CLAMP, SCALE AND CRATE COMBINATION



- The crate combo shall be Taltec or similar approved.
- The length and width of the cattle crate shall be at least 2m, 0.7m and 2.4m respectively.

- Complete pre-assembled unit comprising of heavy duty neck-clamp, scale and crate combination with spring bolt latching sliding doors. Unit to be adaptable to fit removable load-bars.
- The combo weight is 125kg heavy duty neck clamp + 250kg crate =375kg
- Rigid floor and must be self-draining checker plate slats.
- Painted with 2 layers of grey primer and 1 layer of olive green enamel paint.

20.4 SCALE AND LOAD BARS



- The Scale, load bars, and instrument shall be Taltec LS4, or similar approved.
- Electronic scale with LCD screen, 1m loading bars.
- Zero or Cancel the mass of any neck-clamp and crate.
- Voltage indicator of internal battery and charge voltage.
- 12V DC/ 220 Main power supply
- The scale shall be able to weigh animal and crate adjustable between 0 kg and 2400 kg Accuracy to 1kg. Zero or Cancel the mass of any neck-clamp and crate.
- A warranty of at least 12 months is required for the controller.
- Supplied with full operating manual.

20.5 CENTRE POLE



- The centre pole shall be Taltec or similar approved.
- The length and width of the centre pole shall be at least 1.6m.
- Tube diameter shall be 40mm x 3mm thick.
- Painted with 2 layers of grey primer and 1 layer of olive green enamel paint.

20.6 CATTLE KRAAL SIDES/GATES

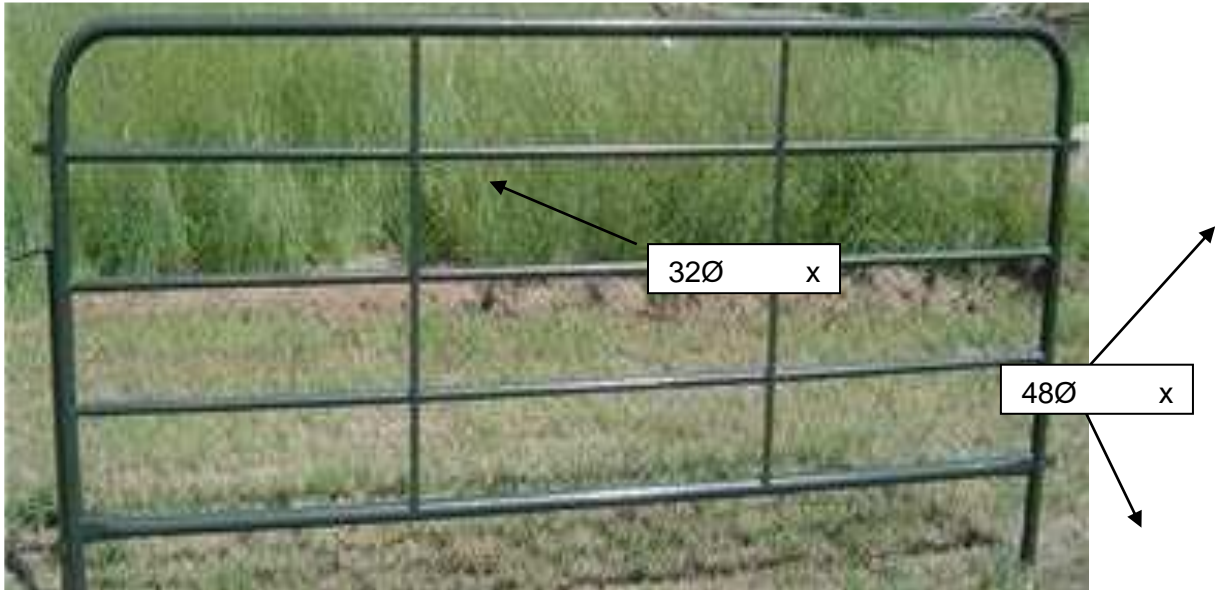

- The gate section shall be Taltec or similar approved.
- The length and width of the cattle kraal side//gates shall be at least 3.0m and 1.60m respectively.
- Tube diameter shall be as shown (See picture above).
- Painted with 2 layers of grey primer and 1 layer of olive green enamel paint.

20.7 CATTLE LOADING RAMP (BARROW)



- The loading ramp shall be Taltec or similar approved.
- The length and width of the loading ramp shall be at least 3.0m and 1.60m respectively.
- Tube diameter shall be 50mm x 2mm thick.

- Ramp shall be adjustable from 0.5m to 1.5m height. The width of the ramp is 0.8m. Ramp to be towable.
- Floor shall be rigid and must be self-draining checker plate slats and steps.
- Fitted with Wheelbarrow wheels.
- Painted with 2 layers of grey primer and 1 layer of olive green enamel paint.

20.8 ACCESS GATE

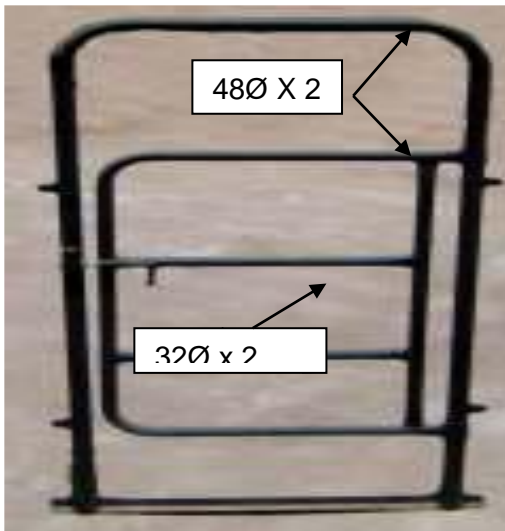

- The gate shall be Taltec or similar approved.
- The length and width of the access gate shall be at least 1.6m and 0.7m respectively.
- Tube diameter shall be as shown (See picture above).
- Painted with 2 layers of grey primer and 1 layer of olive green enamel paint.

20.9 STEEL PIN



- The pin shall be Taltec or similar approved.
- The length and width of the steel pin shall be 16mm diameter and 1.20m long with 8cm bend.
- Painted with 2 layers of grey primer and 1 layer of olive green enamel paint.
- Shall be supplied in quantities sufficient to connect all the kraal sections supplied.

20.10 SINGLE AXLE PORTABLE TRAILER



- The trailer shall be Taltec or similar approved.
- The length and width of the Trailer shall be 4.4m x 2.1m.
- Painted with 2 layers of grey primer and 1 layer of olive green enamel paint.
- The trailer shall have a road worthy certificate, and all the necessary documentation to enable the recipient to register and license the trailer.

20.11 DEMONSTRATION

Supplier will be required to train the beneficiaries on the assembling and disassembling of the complete pre-manufactured handling. Training on the use of scales, crates and neck clamps, shall be included in the session. No demonstration using animals will be required.

PC 20 MEASUREMENT AND PAYMENT

Item	Unit
PC 20.1 Prefabricated sections.....	Number (No.)

The unit of measurement to supply and deliver the pre-fabricated sections shall be the number of units as specified.

The tendered rate shall be in full compensation for supply and delivery to site of the complete unit as per the specifications.

PC 20.2 Demonstration.....	Sum
----------------------------	-----

The unit of measurement to provide the training and demonstration shall be a sum.

The tendered rate shall be in full compensation for providing the training, compensation of the facilitator, transport and all other costs, to provide the demonstration.

21 SECTION 21: STANDARD STOCK WATER SYSTEM

21.1 SCOPE

This section covers the installation of a new stock water system from an existing borehole, and consists of a wind turbine pump assembly, water tanks, drinking troughs and connecting pipes. The complete installation will be as indicated on the drawings or as directed by the Engineer or his representative.

21.2 EARTH WORKS

All Earth Works for Site Clearance, General Earth Works and Earth Works for pipelines shall comply with the specifications as set out in Section 2: Earth Works and also to SANS 2001 – Construction Works Part BS1: Site clearance; SANS 2001 – Construction Works Part BE1: Earth Works (general) and SANS 2001-DP1 Construction Works. Part DP1: Earth Works for buried pipelines and prefabricated culverts.

Payment for Earth Works will be as set out in the relevant Measurement and Payment Clause for the Earth Works Section.

21.3 SAFETY

21.3.1.1 BARRICADING AND LIGHTING

In terms of the applicable regulation of the Machinery and Occupational Safety Act, 1983 (Act 6 of 1983), every excavation that is accessible to the public or that is adjacent to a public road or thoroughfare or by which the safety of persons may be endangered, shall be adequately protected by a barrier or fence of height at least 1 000 mm and as close to the excavation as practicable.

21.3.1.2 STORM WATER AND GROUNDWATER.

The Contractor shall properly deal with and dispose of water to ensure that the works are kept sufficiently dry for their proper execution. His responsibility will be held to include the provision of adequate protection against flooding and damage by storm water, flow from springs, and seepage, and to include provision for the repair, at his expense, of any damage to the works that may arise as a result of the inadequacy of the protection provided by him. Except where the use of tremies has been approved, foundation excavations for structures shall be kept free from water at all times until they have been inspected and approved and concrete footings have been cast.

21.3.1.3 EXCAVATED MATERIAL NOT TO ENDANGER OR INTERFERE.

All excavated material shall be so deposited as not to interfere with or endanger the works (for example, by causing the sides of an excavation to collapse), other property or traffic. The Engineer may order the Contractor to remove any material that the Engineer considers liable to endanger or to interfere with the works, private property, traffic or pedestrians, and to place such material at some other approved location. If the necessity for such removal is, in the opinion of the Engineer, a result of some fault on the part of the Contractor, the cost of removal shall be borne by the Contractor, but otherwise it will be borne by the Employer. All material that is unsuitable or not required for backfilling shall be removed from the site and spread, as ordered, on areas designated by the Engineer.

21.3.1.4 PROTECTING LIVESTOCK

From the time of the site being handed over to the Contractor up to the date of the completion certificate being issued to the contractor, he shall take all measures necessary for preventing the ingress of vermin, and of protecting and controlling livestock, etc. on the sections of the properties affected by his operations. He shall provide gates at the positions in existing fences cut by him for gaining access and shall ensure that all gates are kept closed except when they are opened for admitting his traffic. No fences shall be cut without the approval of the engineer, and consultation with the owner of the fence.

Where alternative arrangements cannot be made, the engineer may direct the contractor to erect temporary fencing where necessary to protect livestock that may be lost or are exposed to vermin through his operations. Such fencing shall be of an adequate standard and shall be erected ahead of construction operations. The fencing shall be maintained in a good order during construction operations and, on completion of the work, it shall be removed from the site and all surfaces shall be restored. The engineer may order that any permanent fencing which is required erected up ahead of construction operations, where practicable, in lieu of erecting temporary fencing.

Payment for the protection of livestock, excluding the erection of temporary fences, shall be included in the amounts tendered for the contractor's establishment on the site.

21.4 CONCRETE WORKS

All Concrete, Formwork and Reinforcement shall comply to the specifications of Section 3: CONCRETE, FORMWORK AND REINFORCEMENT

Structural Works

Applicable standard: SANS 2001 – Construction Works Part CC1: Concrete Works (structural).

Minor Works

Applicable standard: SANS 2001 – Construction Works Part CC2: Concrete Works (minor works).

Foundations

Applicable standard: SANS 2001 – Construction Works Part CM2: Strip footings, Pad footings and Slab-on-the-ground Foundations for Masonry Walling

Payment for Concrete works and items will be as set out in the relevant Measurement and Payment Clause for the Concrete Section.

21.4.1 COMPACTION.

The concrete shall be fully compacted by approved means during and immediately after placing. It shall be thoroughly worked against the formwork and around reinforcement and other embedded items without displacing them.

The concrete shall be free from honeycombing and planes of weakness. Successive layers of the same lift shall be thoroughly worked together. To achieve this, the compaction tool shall penetrate through the new layer to the lower layer which shall still be sufficiently plastic to permit interknitting.

Compaction shall be carried out by mechanical vibration or (if approved) by spading, prodding, or forking. Over vibration resulting in segregation, surface laitance, or leakage, or any combination of these, shall not be permitted.

21.4.2 CURING AND PROTECTION.

After formwork has been removed and as soon as it is practicable in the opinion of the Engineer, all concrete shall be protected from contamination and loss of moisture by one or more of the following methods:

- a) Ponding the exposed surfaces by means of water except under cold weather conditions (concrete surfaces shall not be wet intermittently by spraying or otherwise).
- b) Covering the concrete with sand or mats made of moisture retaining material, and keeping the covering continuously wet
- c) The use of an approved curing compound applied in accordance with the manufacturer's instructions. The curing period shall be at least 5days for the concrete made with Portland cement, at least 2days for concrete made with rapid – hardening Portland cement, and at least 7days if Portland blast furnace cement is used. When atmospheric temperature is below 5°C, these minimum curing periods shall be extended by 72hours, 36hours, and 72hours respectively.

21.4.3 CONCRETE SURFACES.

Exposed surfaces of concrete not finished against forms (such as horizontal or slightly sloping surfaces) shall be brought up to a plane, uniform surface with suitable screed boards.

Where a wood float or steel float finish or a screed topping or a granolithic finish is required in terms of the project specification, the concrete shall, unless otherwise stated in the project specification, be finished to the applicable tolerances specified.

Finished concrete shall have a neat, smooth, even and uniform finish free from any honeycombing. If the finish of any formed or floated concrete surface is unsatisfactory and does not conform to that specified, the Contractor will be required, at his own expense, to rub down such surface while it is still green, or, alternatively, to grind it down with carborundum or other suitable material when it has hardened, or to take other approved remedial measures to give the specified finish.

21.5 MATERIALS AND DIMENTIONS FOR WATER TANKS TERRAIN FENCE

21.5.1 CORNER- AND GATE POSTS AND BRACES:

Corner-, Straining-, Anchor-, Gate Posts and Braces shall be as per SECTION 19: STOCK FENCES.

21.5.2 STANDARDS:

Standards shall be shall be as per SECTION 19: STOCK FENCES.

Standards shall be spaced at 5m intervals for the water tanks fence.

21.5.3 WIRE:

Wire shall be as per specifications in SECTION 19: STOCK FENCES. (2,00mm diameter lightly galvanised zinc-coated mild steel barbed wire double-strand uni-directional twist wire, each strand 2mm in diameter, for use at any height above ground. Barbs shall be manufactured from 1,8mm - 2,0mm lightly galvanized zinc-coated mild steel wire and shall be spaced at not more than 150 mm)

21.5.4 GALVANIZED WIRE WELDED MESH:

Wire netting shall be Galvanized Wire Welded Mesh. (Lightly galvanized mild-steel wire with a minimum diameter of 1,8 mm, and the mesh size shall be 100 mm x 50 mm x 1200 mm)

Four strands of barbed wire shall be stringed at equal spacing between the top and bottom of the corner posts, to support the welded mesh. All fencing wire shall be tied to the sides of standards and posts to prevent the wires from being displaced or becoming loose.

Wire welded mesh shall be stretched against the fence and properly tied to the fencing wire. The weld mesh shall be secured by soft tying wire at 1,2 m distances along the top, centre and bottom wires and at all standards and corner posts.

21.5.5 GATES:

Gates shall be Heavy Duty Farm Gates manufactured to the dimensions and details as per specifications in SECTION 19: STOCK FENCES. Gates shall be manufactured of mild steel tubing having continuously welded seams.

The width of each gate shall be as shown on the drawings.

Gates shall be complete in every respect, including hinges, washers, bolts and locking chains attached to the gate.

Gates shall be painted with 2 layers of SABS 312 Red Lead Base Primers for Structural Steel and 1 layer of SABS approved grade 1 Silver Shine Aluminum paint.

21.6 WATER TANKS TERRAIN AND PREPARATION

All excavations shall be done and dealt with in accordance with the Earth Works and shall comply with the specifications as set out in Section 2: The top 100 mm soil from the enclosed area (12,5 x 15m) shall be removed.

The water tanks will be placed in the centre of a fence enclosed fire proof area.

The top 100 mm soil from the enclosed area shall be removed.

A damp proof sheet of 250-microns must cover the whole area to prevent any vegetation to grow inside the enclosure. The 250-micron plastic sheet shall be covered with 19/22 mm diameter crushed stone.

The fence shall be at least 5m from the two tanks in any direction.

21.7 WATER TANKS AND PLATFORM

The two 10 000-liter Polyethylene tanks shall be placed next to each other where indicated and must be securely mounted on a 5m x 2,5m concrete slab. The slab is 200 mm thick and excavation for 100 mm is required. Boxing to support the concrete for a height of 100 mm will also be required. Reinforcing steel must be placed 75mm from the bottom of the concrete slab. The reinforcement steel must be welded mesh type BRC Ref 395 (200 x 200mm h o h and shall be 8 mm in diameter), lapping shall be at least 300mm. The 3 m Y section standard shall be placed in the centre of the slab before the concrete is poured and must be driven into the ground until the top is the same height as the water tanks

The water tanks platform must be finished by means Wooden float, top of concrete to be level finish.

The tanks must be anchored to the slab with two (2) strands 4mm binding wire connected to 8 x M16 x 300mm eye bolts embedded into the concrete.

Concrete for the slab must be allowed to dry for 5 days

All above ground pipes and fittings to the tanks from the inlet and outlet pipes shall be 32 mm dia galvanised steel. The pipes must be fastened to the standard with suitable clamps.

21.8 DRINKING TROUGHS AND PLATFORMS

The drinking troughs shall be prefabricated steel or polyethylene with a capacity of 500 liters and/or 160 liters respectively and must be secured on a concrete slab. The troughs must be securely mounted with 25 x 5 mm galvanized steel bands on concrete blocks that are 1000 mm longer and 1000 mm wider than the trough dimensions. The concrete slabs shall be 75 mm thick with 20 MPa strength at 28 days.

The drinking troughs platform must be rough finished by means of Level concrete surface by means of straight-edge after vibrating.

The trough shall have a cover for the ball valve and a drain plug. The Ball Valve assembly and fittings to the trough from the inlet pipes must be compatible to and recommended for the type and size of the delivery pipes.

Alternative Steel or concrete troughs must be pre-approved by the engineer.

All above ground pipes and fittings shall be galvanized steel and must connect to the polyethylene pipes underground.

21.9 PIPES AND FITTINGS

All HDPE pipes shall comply with SANS 8779: 2016: Plastic Piping Systems – Polyethylene (PE) Pipes for Irrigation specifications.

All steel piping shall comply with SANS 62 which covers the requirements for two classes (medium and heavy-based on wall thickness) of welded and seamless steel pipes with screwed or plain ends and of nominal size in the range 8mm to 150mm.

All delivery pipelines shall be as indicated on the Bill of Quantities and attached drawings with suitable joints and clamps, in accordance to the prescribes SANS standards, to diameters and classes as indicated on the drawings and fitted with the prescribed connections and fittings to the troughs, water tank and pump.

All pipes for underground use shall be HDPE Polyethylene Pipes and Compression Fittings as per the drawing dimensions and all pipes must carry the SANS mark

All above ground steel pipes shall be Class 17 Galvanised steel pipes with screw & socket joints and diameter as per drawing.

21.10 STEEL PIPE ANCHOR BLOCKS (ABOVE GROUND)

On terrain where it is not possible to lay the pipe underground, steel pipe will be used above ground.

The steel pipe will be anchored by means of a 500mm Y-standard or I-Standard that is hammered into the soil to a depth of 300mm. A concrete anchor block with dimensions of

400mm x 400mm x 400mm will be casted around the Y-standard or I-standard to fasten the steel pipe.

The spacing of the anchor blocks will be at 6m intervals with a union on every third pipe.

21.11 WIND TURBINE AND SUBMERSIBLE ELECTRIC PUMPSET

The turbine shall be equal or similar to Eveready Kestell e300 Wind Turbine with output of 200W at 5 mps wind speed and to include all fittings and 9m tower.

Supply and deliver similar or equal to Grundfos SQ Flex pump to deliver 500 lph at 70 m height to include electrical cable, safety rope and Class 10 HDPE pipe. The system delivery and working pressure as indicated on the drawings if necessary.

The wind turbine with submersible pump assembly must be installed and tested by the manufacturer at the borehole as indicated on the drawing. Fittings to the pump from the main pipeline must be compatible to and recommended for the type and size of the pipes.

Fittings to the pump from the main pipeline must be compatible to and recommended for the type and size of the pipes. The pipe from the surface to the pump shall be at least Class 10 HDPE with SANS mark. The pump shall be anchored to the top of the casing with a 20 mm braided nylon rope.

The wind turbine must provide enough electricity to drive the submersible pump motor under a full load.

All electrical fittings and connections shall be performed by a certified electrician according to EHFOM regulations and the certificate of compliance must be submitted to the Engineer.

The turbine foundation shall be 1 x 1 x 1m of 30 MPa/19 concrete Ready mix only.

21.12 SPECIALS, VALVES, EXTRA'S

T-pieces, reducing sockets, reducing bushes, elbows and end caps shall be to the specified type and sizes indicated, compatible to and recommended for the type and size of the pipeline, in accordance to SANS 966.

Ball valve assemblies, non-return valves and gate valves must be complete with connecting attachments, and must be compatible to and recommended for the type and size of the pipes.

Each pipe and each special/fitting shall be thoroughly cleaned and carefully examined for damage and defects immediately before laying. Should any damaged or defective pipe or fitting be laid, it shall be removed and replaced by the Contractor at his expense. Every reasonable precaution shall be taken to prevent the entry of foreign matter or water into the pipes. During laying and jointing of pipes the trenches shall be kept reasonably dry.

Pipelines shall be jointed in accordance with the manufacturer's instructions and with their recommended joints and clamps. All specials and fittings shall be correctly set, supported, and placed in position as the work proceeds, and shall be properly jointed to their respective pipes.

Testing and commissioning of the system shall be carried out by the Contractor at his expense, in the presence of the engineer's representative.

21.13 BOREHOLE PUMP PROTECTION

The pump protection cover shall be constructed with a ring foundation of 300mm wide and 200mm deep. The Rocla or similar manhole shall be fixed on the ring foundation and secured. Use Rocla 750mm dia round manhole, 500mm high with lid, or similar approved.

The installation shall protrude not more than 150mm above the ground level.

PC 21 MEASUREMENT AND PAYMENT

Item	Unit
PC 21.1 Pipe Anchor Blocks	Number (No)

The unit of measurement for the anchor blocks shall be in number (No) along the length of the pipe line as indicated on site by the engineer.

The tendered rates shall be in full compensation for the supply and delivery of all materials and components required to the site to construct the anchor blocks as specified and full compensation for all labour, tools and equipment to excavate foundations, build form boxes and mix and place the concrete

Item	Unit
PC 21.2 Steel Pipes with Fittings	metre (m)

The unit of measurement for the pipes shall be in length, by meter (m), according to size and class as specified in the Bill of Quantities.

The tendered rates shall be in full compensation for the supply and delivery of all materials, fittings and components required to the site and laying the pipes and connecting fittings as specified and includes labour.

Item	Unit
PC 21.3 HDPE Polyethylene Pipes and Fittings	metre (m)

The unit of measurement for the pipes shall be in length, by meter (m), according to size and class as specified in the Bill of Quantities.

The tendered rates shall be in full compensation for the supply and delivery of all materials and components required to the site and laying the pipes and connecting fittings as specified.

Item	Unit
PC 21.4 Wind Turbine	Number (no)

The unit of measurement for the wind turbine set complete shall be the number (No) of the components as specified in the Bill of Quantities.

The tendered rates shall be in full compensation for the supply and delivery of all materials and components required to the site to install the wind turbine assembly as specified.

Item	Unit
-------------	-------------

PC 21.5 Pump Set Number (no)

The unit of measurement for the pump set complete shall be the number (no) of the components as specified in the Bill of Quantities.

The tendered rates shall be in full compensation for the supply and delivery of all materials and components required to the site to install the pump set assembly as specified.

Item **Unit**

PC 21.6 Labour for Erection of Wind Turbine and Installation of Pump Set (Sum)

The unit of measurement for the labour to excavate the foundation, pour concrete, erect the wind turbine and install the pump set shall be the sum of the construction items.

The tendered rate shall be in full compensation for all labour, tools and equipment for excavation, concrete mixing and pouring, erection of wind turbine, installing the pump, connecting the wind turbine, fitting of all pipes and valves and testing the setup.

Item **Unit**

PC 21.7 Water Tanks Number (no)

The unit of measurement for the water tanks setup complete shall be in number (No) of the components as specified in the Bill of Quantities.

The tendered rates shall be in full compensation for the supply and delivery of all materials and components required to the site for the water tanks as specified.

Item **Unit**

PC 21.8 Water Tanks Anchor Bolts, Pipe Fittings, Connections, Valves, Y-Standards and Anchor Wire (sum)

The unit of measurement for supply and delivery of all anchor bolts, y-standards, anchor wire, pipe fittings and connection fittings, valves and valves shall be measured in sum to anchor and connect the water tanks.

The tendered rates shall be in full compensation for the supply and delivery of all materials and components required to the site for the water tanks connection as specified and mount tanks and do connections of fittings and pipes and testing for leaks.

Item **Unit**

PC 21.9 Water Tanks Terrain Stone Fill cubic metre (m³)

The unit of measurement for supply and delivery of stone material shall be measured in volume, by cubic meter (cub m), for the stone fill of water tank terrain.

The tendered rates shall be in full compensation for the supply and delivery of all materials and components required to the site for the water tanks terrain stone fill as specified, excavate the top soil and placing the stones.

Item **Unit**

PC 21.10 Water Tanks Fence Sum (sum)

The unit of measurement for the water tank fence shall be a sum as specified in the Bill of Quantities.

The tendered rates shall be in full compensation for the supply and delivery of all materials and components required to the site for erecting (excavate the holes, setting the posts, mixing and placing the concrete, to string and tying the wires to the posts, set mixing and placing the concrete, to string and tying the standards, attaching the weld mash and hanging the gate) of the fence around the water tanks terrain as specified.

Item **Unit**

PC 21.11 Drinking Troughs Complete with Valves and Fittings Number (no)

The unit of measurement for the drinking trough setup complete shall be in number (No) of the components as specified in the Bill of Quantities.

The tendered rates shall be in full compensation for the supply and delivery drinking troughs, all pipe fittings, connections, valves and fittings needed to complete drinking troughs and include labour.

Item **Unit**

PC 21.12 SPECIALS, VALVES, EXTRA'S Sum (sum)

The unit of measurement for the specials, valves and extras shall be a sum as specified in the Bill of Quantities.

The rates tendered shall be in full compensation for all labour, tools and equipment to supply, deliver, handle, inspect, transport to the site, mixing of materials, placing of concrete, mounting, assembling, fitting, connecting and installing of all specials, valves and extra's as specified in the Bill of Quantities.

Item **Unit**

PC 21.13 Borehole pump protection Number (no)

The unit of measurement for the borehole pump protection shall be in number (No) of the components as specified in the Bill of Quantities.

The tendered rates shall be in full compensation for the supply and delivery all materials and fittings needed to complete the borehole pump protection and include labour.

22 SECTION 22: CATTLE PLUNGE DIP WITH STEEL HANDLING FACILITY

22.1 SCOPE

This specification covers the supply, delivery and construction of cattle plunge dip tank and stock water system, including the animal handling facility, crush with neck clamp, evaporation pond with security fence, steel storage shed and perimeter fence.

22.2 EARTH WORKS

All Earth Works for Site Clearance, General Earth Works and Earth Works for pipelines shall comply with the specifications as set out in Section 2: Earth Works and also to SANS 2001 – Construction Works Part BS1: Site clearance; SANS 2001 – Construction Works Part BE1: Earth Works (general) and SANS 2001-DP1 Construction Works. Part DP1: Earth Works for buried pipelines and prefabricated culverts.

Payment for Earth Works will be as set out in the relevant Measurement and Payment Clause for the Earth Works Section.

22.2.1 SAFETY

22.2.1.1 BARRICADING AND LIGHTING

In terms of the applicable regulation of the Machinery and Occupational Safety Act, 1983 (Act 6 of 1983), every excavation that is accessible to the public or that is adjacent to a public road or thoroughfare or by which the safety of persons may be endangered, shall be adequately protected by a barrier or fence of height at least 1 000 mm and as close to the excavation as practicable.

22.2.1.2 STORM WATER AND GROUNDWATER.

The Contractor shall properly deal with and dispose of water to ensure that the works are kept sufficiently dry for their proper execution. His responsibility will be held to include the provision of adequate protection against flooding and damage by storm water, flow from springs, and seepage, and to include provision for the repair, at his expense, of any damage to the works that may arise as a result of the inadequacy of the protection provided by him. Except where the use of tremies has been approved, foundation excavations for structures shall be kept free from water at all times until they have been inspected and approved and concrete footings have been cast.

22.2.1.3 EXCAVATED MATERIAL NOT TO ENDANGER OR INTERFERE.

All excavated material shall be so deposited as not to interfere with or endanger the works (for example, by causing the sides of an excavation to collapse), other property or traffic. The Engineer may order the Contractor to remove any material that the Engineer considers liable to endanger or to interfere with the works, private property, traffic or pedestrians, and to place such material at some other approved location. If the necessity for such removal is, in the opinion of the Engineer, a result of some fault on the part of the Contractor, the cost of removal shall be borne by the Contractor, but otherwise it will be borne by the Employer. All material that is unsuitable or not required for backfilling shall be removed from the site and spread, as ordered, on areas designated by the Engineer.

22.2.2 PROTECTING LIVESTOCK

From the time of the site being handed over to the Contractor up to the date of the completion certificate being issued to the contractor, he shall take all measures necessary for preventing the ingress of vermin, and of protecting and controlling livestock, etc. on the sections of the properties affected by his operations. He shall provide gates at the positions in existing fences cut by him for gaining access and shall ensure that all gates are kept closed except when they are opened for admitting his traffic. No fences shall be cut without the approval of the engineer, and consultation with the owner of the fence.

Where alternative arrangements cannot be made, the engineer may direct the contractor to erect temporary fencing where necessary to protect livestock that may be lost or are exposed to vermin through his operations. Such fencing shall be of an adequate standard and shall be erected ahead of construction operations. The fencing shall be maintained in a good order during construction operations and, on completion of the work, it shall be removed from the site and all surfaces shall be restored. The engineer may order that any permanent fencing which is required erected up ahead of construction operations, where practicable, in lieu of erecting temporary fencing.

Payment for the protection of livestock, excluding the erection of temporary fences, shall be included in the amounts tendered for the contractor's establishment on the site.

22.3 CONCRETE WORKS

All Concrete, Formwork and Reinforcement shall comply to the specifications of Section 3: CONCRETE, FORMWORK AND REINFORCEMENT

Structural Works

Applicable standard: SANS 2001 – Construction Works Part CC1: Concrete Works (structural).

Minor Works

Applicable standard: SANS 2001 – Construction Works Part CC2: Concrete Works (minor works).

Foundations

Applicable standard: SANS 2001 – Construction Works Part CM2: Strip footings, Pad footings and Slab-on-the-ground Foundations for Masonry Walling

ALL CONCRETE WORKS SHALL BE READY MIX CONCRETE

Payment for Concrete will be as set out in the relevant Measurement and Payment Clause for this section.

22.3.1 COMPACTION.

The concrete shall be fully compacted by approved means during and immediately after placing. It shall be thoroughly worked against the formwork and around reinforcement and other embedded items without displacing them.

The concrete shall be free from honeycombing and planes of weakness. Successive layers of the same lift shall be thoroughly worked together. To achieve this, the compaction tool shall penetrate through the new layer to the lower layer which shall still be sufficiently plastic to permit interknitting.

Compaction shall be carried out by mechanical vibration or (if approved) by spading, prodding, or forking. Over vibration resulting in segregation, surface laitance, or leakage, or any combination of these, shall not be permitted.

22.3.2 CURING AND PROTECTION.

After formwork has been removed and as soon as it is practicable in the opinion of the Engineer, all concrete shall be protected from contamination and loss of moisture by one or more of the following methods:

- a) Ponding the exposed surfaces by means of water except under cold weather conditions (concrete surfaces shall not be wet intermittently by spraying or otherwise).
- b) Covering the concrete with sand or mats made of moisture retaining material, and keeping the covering continuously wet
- c) The use of an approved curing compound applied in accordance with the manufacturer's instructions. The curing period shall be at least 5days for the concrete made with Portland cement, at least 2days for concrete made with rapid – hardening Portland cement, and at least 7days if Portland blast furnace cement is used. When atmospheric temperature is below 5°C, these minimum curing periods shall be extended by 72hours, 36hours, and 72hours respectively.

22.3.3 CONCRETE SURFACES.

Exposed surfaces of concrete not finished against forms (such as horizontal or slightly sloping surfaces) shall be brought up to a plane, uniform surface with suitable HFreeed boards.

Where a wood float or steel float finish or a HFreeed topping or a granolithic finish is required in terms of the project specification, the concrete shall, unless otherwise stated in the project specification, be finished to the applicable tolerances specified.

Finished concrete shall have a neat, smooth, even and uniform finish free from any honeycombing. If the finish of any formed or floated concrete surface is unsatisfactory and does not conform to that specified, the Contractor will be required, at his own expense, to rub down such surface while it is still green, or, alternatively, to grind it down with carborundum or other suitable material when it has hardened, or to take other approved remedial measures to give the specified finish.

22.3.4 WATER TIGHT CONCRETE.

The dipping tank, evaporation pond, silt box and main race floor shall be water tight. Special care shall be taken by the Contractor to ensure water tightness, particularly at the construction joints. Should any such section of the dipping tank, evaporation pond, silt box, and main race floor, show any sign of water leakage or penetration after being taken into use, it shall be deemed defective.

The dip tank and evaporation pond will undergo a twenty-one (21) day testing process to measure for any leaks and thereby test the water tightness.

22.3.5 DEFECTS.

The concrete shall be homogenous and free from honeycombing, interstices and planes of weakness. If, after the removal of the forms, the concrete shows any defect, the Contractor shall immediately report such defect to the Engineer, and shall not carry out any patching or remedial work until authorized to do so by the Engineer.

After thorough inspection and investigation of the quality and strength of the defective work and after due consideration of the possible consequences of such defect, the Engineer will either specify the extent and method of repair, or order the demolition and reconstruction of the whole of the defective work to the extent which he considers necessary.

The cost of all such investigation, repair and remedial work and of any demolition and reconstruction of defective work shall be borne by the Contractor and all repair, remedial and reconstruction work shall be executed to the satisfaction of the Engineer.

22.3.6 GROUTED STONE PITCHING

The holding pen area and the race must be cleaned to a slope indicated on the plan. After the clearance of all the organic material, rocks of a high 100 mm – 150 mm must be placed for the whole floor of the holding pen area and the race. After the rocks are placed you compile a mortar mixture of 1:150 and placed it on top and in between the rocks that is placed. The mortar mixture must be smoothed on top of the placed rock.

22.4 HANDLING FACILITY (STEEL COMPONENTS)

22.4.1 GENERAL

All steelwork shall comply with the requirements of the specifications as set out in Section 6: STRUCTURAL STEELWORK as well as that of SANS 2001- Part CS1: Specification for Construction Works – Structural steelwork.

ASSEMBLY

The component parts shall be so assembled that: -

- the whole and all parts of the finished structure are within the tolerances specified;
- no vertical post or horizontal member is cut, or otherwise damaged or forced.

AVOIDANCE OF EXCESSIVE STRESSES DURING CONSTRUCTION

IPE posts or Horizontal members or composite units shall not be subjected to excessive stresses during the assembly, fabrication or erection process.

TOLERANCE

- Spacing for vertical sections ± 20 mm from position indicated on project drawings.
- Spacing for horizontal sections ± 10 mm from position indicated on project drawings

All steelwork with the exception of steel reinforcement for the concrete works must be of grade 300W steel.

All steel shall be painted with 2 layers of SABS 312 Red Lead Base Primers for Structural Steel and 1 layer of SABS approved grade 1 Silver Shine Aluminum paint.

22.4.2 STEEL FOR HANDLING FACILITY

Vertical Posts for race shall be IPE_{aa} 100 x 55 x 2400mm sections with base plates of 150 x 150 x 4mm.

Horizontal members for the cruch and main race shall be Cold Formed Lip Channel sections of 70 x 50 x 20mm.

22.4.3 HEAVY DUTY AUCTION GATES

Auction Gates shall be heavy duty auction type gates manufactured and installed to the dimensions and details shown on the drawings for stock handling purposes and at positions as indicated.

The frame shall be of tubing of bore 42mm and wall thickness of 3,0mm in the case of main frame members, and inside bracing members of gate shall be flat bar of 25mm and thickness of 5mm.

Auction Gates shall be complete in every respect, including hinges, washers, bolts and locking chains attached to the gate.

Gates shall be painted with 2 layers of SABS 312 Red Lead Base Primers for Structural Steel and 1 layer of SABS approved grade 1 Silver Shine Aluminum paint.

22.4.4 NECK CLAMP

The neck clamp must be manufactured of grade 300W steel and must be sufficiently robust for mature beef cattle handling, "Taltec or Similar".

The steel work of the neck clamp must be painted 2 layers of SABS 312 Red Lead Base Primers for Structural Steel and 1 layer of SABS approved grade 1 Silver Shine Aluminum paint.

The neck clamp must be supplied as a pre-assembled unit ready for site installation.



The neck clamp mechanism must be able to operate in the following manner:

- Neck lugs to restrict movement of animal
- Immediate walk through when animal is released
- Automatic lock mechanism which prevents the opening of the yoke due to animal movement
- Manually operated opening lever.
- Full 700mm opening for large animals.
- Variable settings of closure to prevent serious injury to animals.

22.5 MATERIALS AND DIMENTIONS FOR EVAPORATION POND FENCE

22.5.1 CORNER- AND GATE POSTS AND BRACES:

Corner-, Straining-, Anchor-, Gate Posts and Braces shall be as per SECTION 19: STOCK FENCES.

22.5.2 STANDARDS:

Standards shall be shall be as per SECTION 19: STOCK FENCES.

22.5.3 WIRE:

Wire shall be as per specifications in SECTION 19: STOCK FENCES. (2,00mm diameter lightly galvanised zinc-coated mild steel barbed wire double-strand uni-directional twist wire, each strand 2mm in diameter, for use at any height above ground. Barbs shall be

manufactured from 1,8mm - 2,0mm lightly galvanized zinc-coated mild steel wire and shall be spaced at not more than 150 mm)

22.5.4 GALVANIZED WIRE WELDED MESH:

Wire netting shall be Galvanized Wire Welded Mesh. (Lightly galvanized mild-steel wire with a minimum diameter of 1,8 mm, and the mesh size shall be 100 mm x 50 mm x 1200 mm)

Four strands of barbed wire shall be stringed at equal spacing between the top and bottom of the corner posts, to support the welded mesh. All fencing wire shall be tied to the sides of standards and posts to prevent the wires from being displaced or becoming loose.

Wire welded mesh shall be stretched against the fence and properly tied to the fencing wire. The weld mesh shall be secured by soft tying wire at 1,2 m distances along the top, centre and bottom wires and at all standards and corner posts.

22.5.5 GATES:

Gates shall be manufactured to the dimensions and details as per specifications in SECTION 19: STOCK FENCES. Gates shall be manufactured of mild steel tubing having continuously welded seams.

The width of each gate shall be as shown on the drawings.

Gates shall be complete in every respect, including hinges, washers, bolts and locking chains attached to the gate.

Gates shall be painted with 2 x coats high quality Rust Preventative Paint and finish off with 2 x coats Silver Shine Aluminum paint.

22.6 SLUDGE PUMP

Sludge pump shall be a complete unit driven by 4.5kW petrol engine (Honda or similar) 3" with 80mm quick coupling fittings for hoses. The delivery rate must be at least 10 000l/hr. The pump shall be fitted with a 6m suction hose with foot valve and a 15m delivery hose.

All valves and fittings required shall be provided and a warranty of 12 months shall be applicable on pump and engine. Pump and engine shall be fitted on trolley (wheel barrow type) that can be handled by one person.

22.7 STEEL STORAGE SHED

The Steel Storage Shed shall be installed as per drawing or as indicated by the engineer.

All materials, construction and works done shall comply with the specifications as set out in Section 34: STEEL SHED.

Payment for Stock Water System will be as set out in the relevant Measurement and Payment Clause for the Steel Shed Section.

22.8 STOCK WATER SYSTEM

The stock water system shall be installed as per drawing or as indicated by the engineer.

All materials, construction and works done shall comply with the specifications as set out in Section 21: STOCK WATER SYSTEM.

Payment for Stock Water System will be as set out in the relevant Measurement and Payment Clause for the Stock Water System Section.

22.9 STOCK FENCE AROUND DIP TANK AND FACILITIES

The perimeter stock fence shall be installed as per drawing or as indicated by the engineer.

All materials, construction and work done shall comply to the specifications of Section 19: STOCK FENCING

Payment for Perimeter Stock Fence will be as set out in the relevant Measurement and Payment Clause for the Stock Fence Section.

PC 22 MEASUREMENT AND PAYMENT

Item	Unit
PC 22.1 Vertical IPE postsfor crush	Number (No)

The unit of measurement for erecting Vertical IPE Posts shall be the number of posts erected.

The tendered rate shall be in full compensation for supply, delivery of all materials and components required to construct the posts, all labour, tools and plant for the complete erection thereof as specified.

Item	Unit
PC 22.2 Horizontal Lip Channel members	Number (No)

The unit of measurement for erecting horizontal lip channel members shall be the number of members erected.

The tendered rate shall be in full compensation for supply, delivery of all materials and components required to construct the lip channel members, all labour, tools and plant for the complete erection thereof as specified.

Item	Unit
PC 22.3 Grouted Stone Pitching	square metre (m ²)

The unit of measurement for the laying of the grouted stone pitching shall be the square metre area of stone pitching.

The tendered rate shall be in full compensation for supply, delivery of all materials, labour and plant for the complete laying of the stone pitching as per the specifications.

Item	Unit
PC 22.4 Extra Over for Transport on import of stone	(R/km)

Extra over for transport of stone for stone pitching beyond 50km. The rate will be rand/km.

Item	Unit
PC 22.5 Sludge pump	Number (No)

The unit of measurement to supply and deliver the Sludge Pump shall be the number of pumps.

The tendered rate shall be in full compensation for supply and delivery to site of the complete sludge pump unit and trolley as per the specifications, testing of the pump and commissioning thereof.

Item	Unit
PC 22.6 Water supply to dip tank	Sum

The unit of measurement for the supply of water to the dip tank shall be the Sum.

The tendered rates shall be in full compensation for the supply, delivery and installation of the water supply system.

Item	Unit
PC 22.7 Evaporation pond fence	Sum

The unit of measurement for the supply, delivery and installation of evaporation pond fence shall be the Sum.

The tendered rates shall be in full compensation for the supply, delivery and installation of the evaporation pond fence.

23 SECTION 23: CATTLE PLUNGE DIP WITH TIMBER HANDLING FACILITY

23.1 SCOPE

This specification covers the supply, delivery and construction of cattle plunge dip tank and stock water system, including the animal handling facility, crush with neck clamp, evaporation pond with security fence, steel storage shed and perimeter fence.

23.2 EARTH WORKS

All Earth Works for Site Clearance, General Earth Works and Earth Works for pipelines shall comply with the specifications as set out in Section 2: Earth Works and also to SANS 2001 – Construction Works Part BS1: Site clearance; SANS 2001 – Construction Works Part BE1: Earth Works (general) and SANS 2001-DP1 Construction Works. Part DP1: Earth Works for buried pipelines and prefabricated culverts.

Payment for Earth Works will be as set out in the relevant Measurement and Payment Clause for the Earth Works Section.

23.2.1 SAFETY

23.2.1.1 BARRICADING AND LIGHTING

In terms of the applicable regulation of the Machinery and Occupational Safety Act, 1983 (Act 6 of 1983), every excavation that is accessible to the public or that is adjacent to a public road or thoroughfare or by which the safety of persons may be endangered, shall be adequately protected by a barrier or fence of height at least 1 000 mm and as close to the excavation as practicable.

23.2.1.2 STORM WATER AND GROUNDWATER.

The Contractor shall properly deal with and dispose of water to ensure that the works are kept sufficiently dry for their proper execution. His responsibility will be held to include the provision of adequate protection against flooding and damage by storm water, flow from springs, and seepage, and to include provision for the repair, at his expense, of any damage to the works that may arise as a result of the inadequacy of the protection provided by him. Except where the use of tremies has been approved, foundation excavations for structures shall be kept free from water at all times until they have been inspected and approved and concrete footings have been cast.

23.2.1.3 EXCAVATED MATERIAL NOT TO ENDANGER OR INTERFERE.

All excavated material shall be so deposited as not to interfere with or endanger the works (for example, by causing the sides of an excavation to collapse), other property or traffic. The Engineer may order the Contractor to remove any material that the Engineer considers liable to endanger or to interfere with the works, private property, traffic or pedestrians, and to place such material at some other approved location. If the necessity for such removal is, in the opinion of the Engineer, a result of some fault on the part of the Contractor, the cost of removal shall be borne by the Contractor, but otherwise it will be borne by the Employer. All material that is unsuitable or not required for backfilling shall be removed from the site and spread, as ordered, on areas designated by the Engineer.

23.2.2 PROTECTING LIVESTOCK

From the time of the site being handed over to the Contractor up to the date of the completion certificate being issued to the contractor, he shall take all measures necessary for preventing the ingress of vermin, and of protecting and controlling livestock, etc. on the sections of the

properties affected by his operations. He shall provide gates at the positions in existing fences cut by him for gaining access and shall ensure that all gates are kept closed except when they are opened for admitting his traffic. No fences shall be cut without the approval of the engineer, and consultation with the owner of the fence.

Where alternative arrangements cannot be made, the engineer may direct the contractor to erect temporary fencing where necessary to protect livestock that may be lost or are exposed to vermin through his operations. Such fencing shall be of an adequate standard and shall be erected ahead of construction operations. The fencing shall be maintained in a good order during construction operations and, on completion of the work, it shall be removed from the site and all surfaces shall be restored. The engineer may order that any permanent fencing which is required erected up ahead of construction operations, where practicable, in lieu of erecting temporary fencing.

Payment for the protection of livestock, excluding the erection of temporary fences, shall be included in the amounts tendered for the contractor's establishment on the site.

23.3 CONCRETE WORKS

All Concrete, Formwork and Reinforcement shall comply to the specifications of Section 3: CONCRETE, FORMWORK AND REINFORCEMENT

Structural Works

Applicable standard: SANS 2001 – Construction Works Part CC1: Concrete Works (structural).

Minor Works

Applicable standard: SANS 2001 – Construction Works Part CC2: Concrete Works (minor works).

Foundations

Applicable standard: SANS 2001 – Construction Works Part CM2: Strip footings, Pad footings and Slab-on-the-ground Foundations for Masonry Walling

ALL CONCRETE WORKS SHALL BE READY MIX CONCRETE

Payment for Concrete will be as set out in the relevant Measurement and Payment Clause for this section.

23.3.1 COMPACTION.

The concrete shall be fully compacted by approved means during and immediately after placing. It shall be thoroughly worked against the formwork and around reinforcement and other embedded items without displacing them.

The concrete shall be free from honeycombing and planes of weakness. Successive layers of the same lift shall be thoroughly worked together. To achieve this, the compaction tool shall penetrate through the new layer to the lower layer which shall still be sufficiently plastic to permit interknitting.

Compaction shall be carried out by mechanical vibration or (if approved) by spading, prodding, or forking. Over vibration resulting in segregation, surface laitance, or leakage, or any combination of these, shall not be permitted.

23.3.2 CURING AND PROTECTION.

After formwork has been removed and as soon as it is practicable in the opinion of the Engineer, all concrete shall be protected from contamination and loss of moisture by one or more of the following methods:

- a) Ponding the exposed surfaces by means of water except under cold weather conditions (concrete surfaces shall not be wet intermittently by spraying or otherwise).
- b) Covering the concrete with sand or mats made of moisture retaining material, and keeping the covering continuously wet.
- c) The use of an approved curing compound applied in accordance with the manufacturer's instructions. The curing period shall be at least 5days for the concrete made with Portland cement, at least 2days for concrete made with rapid – hardening Portland cement, and at least 7days if Portland blast furnace cement is used. When atmospheric temperature is below 5°C, these minimum curing periods shall be extended by 72hours, 36hours, and 72hours respectively.

23.3.3 CONCRETE SURFACES.

Exposed surfaces of concrete not finished against forms (such as horizontal or slightly sloping surfaces) shall be brought up to a plane, uniform surface with suitable HFreeed boards.

Where a wood float or steel float finish or a HFreeed topping or a granolithic finish is required in terms of the project specification, the concrete shall, unless otherwise stated in the project specification, be finished to the applicable tolerances specified.

Finished concrete shall have a neat, smooth, even and uniform finish free from any honeycombing. If the finish of any formed or floated concrete surface is unsatisfactory and does not conform to that specified, the Contractor will be required, at his own expense, to rub down such surface while it is still green, or, alternatively, to grind it down with carborundum or other suitable material when it has hardened, or to take other approved remedial measures to give the specified finish.

23.3.4 WATER TIGHT CONCRETE.

The dipping tank, evaporation pond, silt box and main race floor shall be water tight. Special care shall be taken by the Contractor to ensure water tightness, particularly at the construction joints. Should any such section of the dipping tank, evaporation pond, silt box, and main race floor, show any sign of water leakage or penetration after being taken into use, it shall be deemed defective.

The dip tank and evaporation pond will undergo a twenty-one (21) day testing process to measure for any leaks and thereby test the water tightness.

23.3.5 DEFECTS.

The concrete shall be homogenous and free from honeycombing, interstices and planes of weakness. If, after the removal of the forms, the concrete shows any defect, the Contractor shall immediately report such defect to the Engineer, and shall not carry out any patching or remedial work until authorized to do so by the Engineer.

After thorough inspection and investigation of the quality and strength of the defective work and after due consideration of the possible consequences of such defect, the Engineer will either specify the extent and method of repair, or order the demolition and reconstruction of the whole of the defective work to the extent which he considers necessary.

The cost of all such investigation, repair and remedial work and of any demolition and reconstruction of defective work shall be borne by the Contractor and all repair, remedial and reconstruction work shall be executed to the satisfaction of the Engineer.

23.3.6 GROUTED STONE PITCHING

The holding pen area and the race must be cleaned to a slope indicated on the plan. After the clearance of all the organic material, rocks of a high 100 mm – 150 mm must be placed for the whole floor of the holding pen area and the race. After the rocks are placed you compile a mortar mixture of 1:150 and placed it on top and in between the rocks that is placed. The mortar mixture must be smoothed on top of the placed rock.

23.4 HANDLING FACILITY (TIMBER COMPONENTS)

23.4.1 POSTS AND RAILS

Posts and Rails shall be Eucalyptus or Pine poles wooden poles and of quality suitable for fencing and to the size indicated on the drawings.

All treated timber poles shall be treated to comply with SABS 457. Timber posts shall be treated with a preservative in accordance with the requirements of SABS 1288 (Preservative treated timber) or SABS 05 (Creosote treated timber).

Posts and Rails shall be treated and bearing the SANS mark.

Vertical Posts shall be 125/150mm diameter x 2.4m length.

Horizontal Members/Rails shall be 100/125mm diameter x 3m length.

At the bottom of each post, 150mm from the bottom of the post, a 10mm hole will be drilled through the post. Thereafter a 10mm reinforcing bar of 200mm will be fitted in the hole before planting the post.

23.4.2 FABRICATION

CUTTING

Cutting may be done by sawing. Edges shall be free from any defects or distortions that may adversely affect the strength or serviceability of the member. All exposed burrs and similar defects shall be ground off and smoothed. The edges shall be sprayed or hand brushed with chemical after cutting in accordance with SANS 100005:2006: 8.1.1 to prevent the timber be exposed to insects or termites or fungal attack as specified by Hazard class H0-it⁰.

The Contractor shall ensure that all poles are fully preserved and comply with the requirement of the relevant national standard of SANS 10005:2006, SANS538 (creosoted with high temperature and be treated under moderate pressure for all resistant poles like eucalyptus) SANS 754 and SANS 753.

ASSEMBLY

GENERAL

The component parts shall be so assembled that: -

- the whole and all parts of the finished structure are within the tolerances specified;
- no cross-pole is cut, or otherwise damaged or forced to crack at the edges;

AVOIDANCE OF EXCESSIVE STRESSES DURING CONSTRUCTION

Drilling of vertical poles, cross-poles or composite units shall not be subjected to excessive stresses during the assembly, fabrication or erection process.

DRILLING

Drilling shall be carried out by hand as shown on plan or in accordance to the relevant recommendations.

TOLERANCE

- Spacing for vertical sections ± 20 mm from position indicated on project drawings.
- Spacing for horizontal sections ± 10 mm from position indicated on project drawings.

23.4.3 HEAVY DUTY AUCTION GATES

Auction Gates shall be heavy duty auction type gates manufactured and installed to the dimensions and details shown on the drawings for stock handling purposes and at positions as indicated.

The frame shall be of tubing of bore 42mm and wall thickness of 3,0mm in the case of main frame members, and inside bracing members of gate shall be flat bar of 25mm and thickness of 5mm.

Auction Gates shall be complete in every respect, including hinges, washers, bolts and locking chains attached to the gate.

Gates shall be painted with 2 layers of SABS 312 Red Lead Base Primers for Structural Steel and 1 layer of SABS approved grade 1 Silver Shine Aluminum paint

23.4.4 NECK CLAMP

The neck clamp must be manufactured of grade 300W steel and must be sufficiently robust for mature beef cattle handling, "Taltec or Similar".

The steel work of the neck clamp must be painted 2 layers of SABS 312 Red Lead Base Primers for Structural Steel and 1 layer of SABS approved grade 1 Silver Shine Aluminum paint.

The neck clamp must be supplied as a pre-assembled unit ready for site installation.



The neck clamp mechanism must be able to operate in the following manner:

- Neck lugs to restrict movement of animal
- Immediate walk through when animal is released
- Automatic lock mechanism which prevents the opening of the yoke due to animal movement
- Manually operated opening lever.
- Full 700mm opening for large animals.
- Variable settings of closure to prevent serious injury to animals.

23.5 MATERIALS AND DIMENTIONS FOR EVAPORATION POND FENCE

23.5.1 CORNER- AND GATE POSTS AND BRACES:

Corner-, Straining-, Anchor-, Gate Posts and Braces shall be as per SECTION 19: STOCK FENCES.

23.5.2 STANDARDS:

Standards shall be shall be as per SECTION 19: STOCK FENCES.

23.5.3 WIRE:

Wire shall be as per specifications in SECTION 19: STOCK FENCES. (2,00mm diameter lightly galvanised zinc-coated mild steel barbed wire double-strand uni-directional twist wire, each strand 2mm in diameter, for use at any height above ground. Barbs shall be manufactured from 1,8mm - 2,0mm lightly galvanized zinc-coated mild steel wire and shall be spaced at not more than 150 mm)

23.5.4 GALVANIZED WIRE WELDED MESH:

Wire netting shall be Galvanized Wire Welded Mesh. (Lightly galvanized mild-steel wire with a minimum diameter of 1,8 mm, and the mesh size shall be 100 mm x 50 mm x 1200 mm)

Four strands of barbed wire shall be stringed at equal spacing between the top and bottom of the corner posts, to support the welded mesh. All fencing wire shall be tied to the sides of standards and posts to prevent the wires from being displaced or becoming loose.

Wire welded mesh shall be stretched against the fence and properly tied to the fencing wire. The weld mesh shall be secured by soft tying wire at 1,2 m distances along the top, centre and bottom wires and at all standards and corner posts.

23.5.5 GATES:

Gates shall be manufactured to the dimensions and details as per specifications in SECTION 19: STOCK FENCES. Gates shall be manufactured of mild steel tubing having continuously welded seams.

The width of each gate shall be as shown on the drawings.

Gates shall be complete in every respect, including hinges, washers, bolts and locking chains attached to the gate.

Gates shall be painted with 2 x coats high quality Rust Preventative Paint and finish off with 2 x coats Silver Shine Aluminum paint.

23.6 SLUDGE PUMP

Sludge pump shall be a complete unit driven by 4.5kW petrol engine (Honda or similar) 3" with 80mm quick coupling fittings for hoses. The delivery rate must be at least 10 000l/hr. The pump shall be fitted with a 6m suction hose with foot valve and a 15m delivery hose.

All valves and fittings required shall be provided and a warranty of 12 months shall be applicable on pump and engine. Pump and engine shall be fitted on trolley (wheel barrow type) that can be handled by one person.

23.7 STEEL STORAGE SHED

The Steel Storage Shed shall be installed as per drawing or as indicated by the engineer.

All materials, construction and works done shall comply with the specifications as set out in Section 34: STEEL SHED.

Payment for Stock Water System will be as set out in the relevant Measurement and Payment Clause for the Steel Shed Section.

23.8 STOCK WATER SYSTEM

The stock water system shall be installed as per drawing or as indicated by the engineer.

All materials, construction and works done shall comply with the specifications as set out in Section 21: STOCK WATER SYSTEM.

Payment for Stock Water System will be as set out in the relevant Measurement and Payment Clause for the Stock Water System Section.

23.9 STOCK FENCE AROUND DIP TANK AND FACILITIES

All materials, construction and measurement and payment shall comply to the specifications of Section 19: STOCK FENCING

PC 23 MEASUREMENT AND PAYMENT

Item	Unit
PC 23.1 Vertical Posts (125/150 x 2.4m Length)	Number (No)

The unit of measurement for erecting Vertical Timber Posts shall be the number of posts erected.

The tendered rate shall be in full compensation for supply, delivery of all materials and components required to construct the posts, all labour, tools and plant for the complete erection thereof as specified.

Item	Unit
PC 23.2 Horizontal Rails (100/125 x 3m length)	Number (No)

The unit of measurement for erecting Horizontal Timber Rails shall be the number of rails erected.

The tendered rate shall be in full compensation for supply, delivery of all materials and components required to construct the posts, all labour, tools and plant for the complete erection thereof as specified.

Item	Unit
PC 23.3 10 mm Rebars (250mm long)	Number (No)

The unit of measurement for fixing the 10 mm rebars through the bottom of vertical poles shall be the number of rebars.

The tendered rate shall be in full compensation for supply, delivery of all materials and components required to site, all labour, tools and plant for the cutting, drilling of holes and fixing of rebars to ensure the complete erection thereof as specified.

Item	Unit
PC 23.4 M12 threaded bar with flat washers and hexagonal nuts	Number (No)

The unit of measurement for fixing the M 12 threaded bar with washers and lock nuts shall be the number as per bill.

The tendered rate shall be in full compensation for supply, delivery of all materials and components required to site, all labour, tools and plant for the cutting, drilling of holes and fixing of M 12 threaded bar with washers and lock nuts to ensure the complete erection thereof as specified.

Item	Unit
PC 23.5 Grouted Stone Pitching	square metre (m ²)

The unit of measurement for the laying of the grouted stone pitching shall be the square metre area of stone pitching.

The tendered rate shall be in full compensation for supply, delivery of all materials, labour and plant for the complete laying of the stone pitching as per the specifications.

Item	Unit
PC 23.6 Extra Over for Transport on import of stone	(R/km)

Extra over for transport of stone for stone pitching beyond 50km. The rate will be rand/km.

Item	Unit
PC 23.7 Sludge pump	Number (No)

The unit of measurement to supply and deliver the Sludge Pump shall be the number of pumps.

The tendered rate shall be in full compensation for supply and delivery to site of the complete sludge pump unit and trolley as per the specifications, testing of the pump and commissioning thereof.

Item	Unit
PC 23.7 Auction Gate (3.0m x 1.5m high)	Number (No)

The unit of measurement for the gate complete shall be the number (No) of gates erected as per the specifications and drawings.

The tendered rates shall be in full compensation for the supply, delivery of all materials and components required to the site all labour, tools and plant to install the gates as indicated on the drawings.

Item	Unit
PC 23.8 Water supply to dip tank	Sum

The unit of measurement for the supply of water supply system to the dip tank shall be the Sum.

The tendered rates shall be in full compensation for the supply, delivery an installation of the water supply system.

Item	Unit
PC 23.9 Evaporation pond fence	Sum

The unit of measurement for the supply, delivery and installation of evapuation pond fence shall be the Sum.

The tendered rates shall be in full compensation for the supply, delivery an installation of the evaporation pond fence.

24 SECTION 24: STANDARD SHEARING SHED.

24.1 SCOPE

This specification covers the supply, delivery and construction of shearing shed.

24.2 EARTH WORKS

All Earth Works for Site Clearance, General Earth Works and Earth Works for pipelines shall comply with the specifications as set out in Section 2: Earth Works and also to SANS 2001 – Construction Works Part BS1: Site clearance; SANS 2001 – Construction Works Part BE1: Earth Works (general) and SANS 2001-DP1 Construction Works. Part DP1: Earth Works for buried pipelines and prefabricated culverts.

Payment for Earth Works will be as set out in the relevant Measurement and Payment Clause for this section.

24.2.1 SAFETY

24.2.1.1 BARRICADING AND LIGHTING

In terms of the applicable regulation of the Machinery and Occupational Safety Act, 1983 (Act 6 of 1983), every excavation that is accessible to the public or that is adjacent to a public road or thoroughfare or by which the safety of persons may be endangered, shall be adequately protected by a barrier or fence of height at least 1 000 mm and as close to the excavation as practicable.

24.2.1.2 STORM WATER AND GROUNDWATER.

The Contractor shall properly deal with and dispose of water to ensure that the works are kept sufficiently dry for their proper execution. His responsibility will be held to include the provision of adequate protection against flooding and damage by storm water, flow from springs, and seepage, and to include provision for the repair, at his expense, of any damage to the works that may arise as a result of the inadequacy of the protection provided by him. Except where the use of tremies has been approved, foundation excavations for structures shall be kept free from water at all times until they have been inspected and approved and concrete footings have been cast.

24.2.1.3 EXCAVATED MATERIAL NOT TO ENDANGER OR INTERFERE.

All excavated material shall be so deposited as not to interfere with or endanger the works (for example, by causing the sides of an excavation to collapse), other property or traffic. The Engineer may order the Contractor to remove any material that the Engineer considers liable to endanger or to interfere with the works, private property, traffic or pedestrians, and to place such material at some other approved location. If the necessity for such removal is, in the opinion of the Engineer, a result of some fault on the part of the Contractor, the cost of removal shall be borne by the Contractor, but otherwise it will be borne by the Employer. All material that is unsuitable or not required for backfilling shall be removed from the site and spread, as ordered, on areas designated by the Engineer.

24.2.1.4 PROTECTING LIVESTOCK

From the time of the site being handed over to the Contractor up to the date of the completion certificate being issued to the contractor, he shall take all measures necessary for preventing the ingress of vermin, and of protecting and controlling livestock, etc. on the sections of the properties affected by his operations. He shall provide gates at the positions in existing fences cut by him for gaining access and shall ensure that all gates are kept closed except when they

are opened for admitting his traffic. No fences shall be cut without the approval of the engineer, and consultation with the owner of the fence.

Where alternative arrangements cannot be made, the engineer may direct the contractor to erect temporary fencing where necessary to protect livestock that may be lost or are exposed to vermin through his operations. Such fencing shall be of an adequate standard and shall be erected ahead of construction operations. The fencing shall be maintained in a good order during construction operations and, on completion of the work, it shall be removed from the site and all surfaces shall be restored. The engineer may order that any permanent fencing which is required erected up ahead of construction operations, where practicable, in lieu of erecting temporary fencing.

Payment for the protection of livestock, excluding the erection of temporary fences, shall be included in the amounts tendered for the contractor's establishment on the site.

24.2.2 COMPACTED FILLING MATERIAL SUPPLIED BY THE CONTRACTOR

24.2.2.1 COMPACTION MATERIAL UNDER FLOOR

Filling under solid floor will be executed with imported G5 material dry earth, free from clay and spread evenly in layers not more than 200mm thick, well compacted.

The subgrade shall be compacted to 95% MOD ASSHTO density. A minimum of six positions shall be pointed out by the Engineer for density testing. The first passed test shall be paid in accordance to the bill of quantities. Should the test fail, the contractor shall be liable for the re-compaction and the subsequent tests of the re-compacted materials until it meet the required compaction strength.

When in the opinion of the Engineer, the density of the under surface material is not suitable, the surface shall be scarified to a depth of 150mm with a mechanical ripper or other approved equipment, watered and re-compacted to 90% MOD ASSHTO density

24.2.2.2 GRAVEL DRESSING OF CONSOLIDATED 75MM THICKNESS

Gravel cover on tarrain will be executed with imported G5 material dry earth, free from clay and spread evenly in layers, well compacted to a minimum thickness of 75mm.

24.3 CONCRETE WORKS

All Concrete, Formwork and Reinforcement shall comply to the specifications of Section 3: CONCRETE, FORMWORK AND REINFORCEMENT, and the relevant drawings and bill of quantities.

24.3.1 READY MIX CONCRETE

All concrete elements shall be executed with ready mix concrete, unless otherwise instructed by the Engineer.

The contractor shall take care to order ready mix concrete to the correct specifications for the specific element, and manageable quantities, in order to pour, place and finish while the concrete is workable.

24.3.2 CURING AND PROTECTION.

After formwork has been removed and as soon as it is practicable in the opinion of the Engineer, all concrete shall be protected from contamination and loss of moisture by one or more of the following methods:

- Ponding the exposed surfaces by means of water except under cold weather conditions (concrete surfaces shall not be wet intermittently by spraying or otherwise).
- Covering the concrete with sand or mats made of moisture retaining material, and keeping the covering continuously wet
- The use of an approved curing compound applied in accordance with the manufacturer's instructions. The curing period shall be at least 5days for the concrete made with Portland cement, at least 2days for concrete made with rapid – hardening Portland cement, and at least 7days if Portland blast furnace cement is used. When atmospheric temperature is below 5°C, these minimum curing periods shall be extended by 72hours, 36hours, and 72hours respectively.

24.3.3 DEFECTS.

The concrete shall be homogenous and free from honeycombing, interstices and planes of weakness. If, after the removal of the forms, the concrete shows any defect, the Contractor shall immediately report such defect to the Engineer, and shall not carry out any patching or remedial work until authorized to do so by the Engineer.

After thorough inspection and investigation of the quality and strength of the defective work and after due consideration of the possible consequences of such defect, the Engineer will either specify the extent and method of repair, or order the demolition and reconstruction of the whole of the defective work to the extent which he considers necessary.

The cost of all such investigation, repair and remedial work and of any demolition and reconstruction of defective work shall be borne by the Contractor and all repair, remedial and reconstruction work shall be executed to the satisfaction of the Engineer.

24.4 MASONRY WORKS

All masonry work shall comply to the specification of SECTION 4: MASONRY, and the relevant drawings.

24.4.1 BRICK WORK

All brick work shall be executed with burnt clay bricks, as specified in Section 4.

24.4.2 BRICK REINFORCING

Unless otherwise described, brick work reinforcement is to of approved SA manufactured welded high-tensile steel wire reinforcing fabric of the width stated, cut to length and lapped full width at corners and passing. Rate shall be included in the rate of brick and block work, built into walls at every third layer.

24.5 WINDOWS DOORS AND FITTINGS

All windows, doors and fittings shall comply to the specifications of:

- SECTION 7: METALWORK
- SECTION 11: JOINERY
- SECTION 12: IRONMONGARY
- SECTION 14: INSTALLTION OF GLAZING IN WINDOWS

And specifications of relevant drawings.

24.5.1 WINDOWS

All windows will be Durawin or equally approved SS33, fitted and protected against damage while built in.

All windows will be fitted with burglarproofing on the opening sections.

Fitted with 3mm clear float glass.

Painted two coats of red oxide steel primer, and two coats of high quality gloss enamel paint. Colour to be agreed with the Engineer.

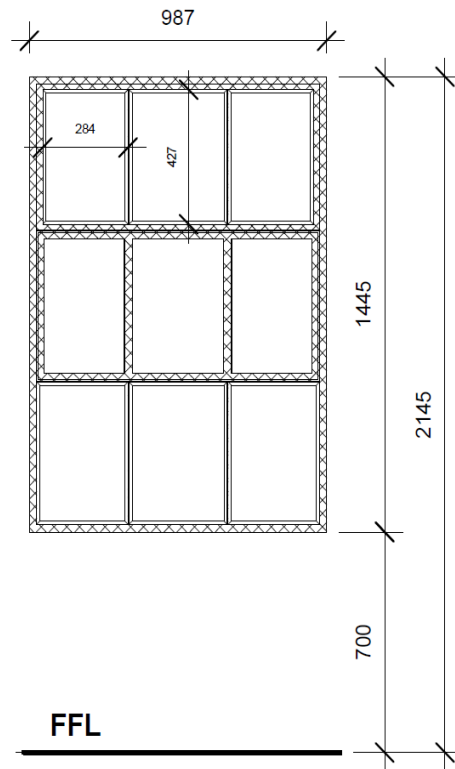

24.5.2 DOOR FRAMES

Door frames shall be Durowin steel frames or equally approved. Door size of 2078 x 805mm. Each frame shall have 4 x 300mm galvanized hoop iron building in lugs per frame style. It must be factory primed red oxide, and damaged areas touched-up and painted with red-oxide steel primer.

Apply two coats of high quality gloss enamel paint. Colour to be agreed with the Engineer.

24.5.3 HARDWOOD DOORS

Door to be 2076x805x44mm, selected red meranti. Framed ledged, framed and battered door with 8mm smooth rempered hardwood flush internal panelling.

108 x44mm top rails and styles. 220 x 20mm lock rail and bottom rail.

Standard 70x44mm hardwood weather bar fitted to bottom edge.

Apply three coats of high quality, clear external varnish.

Upper edge cylinder Como door lock, code BP 8100.

Yale night hatch Y3 – Satin Chrome model P-85-SC-40.

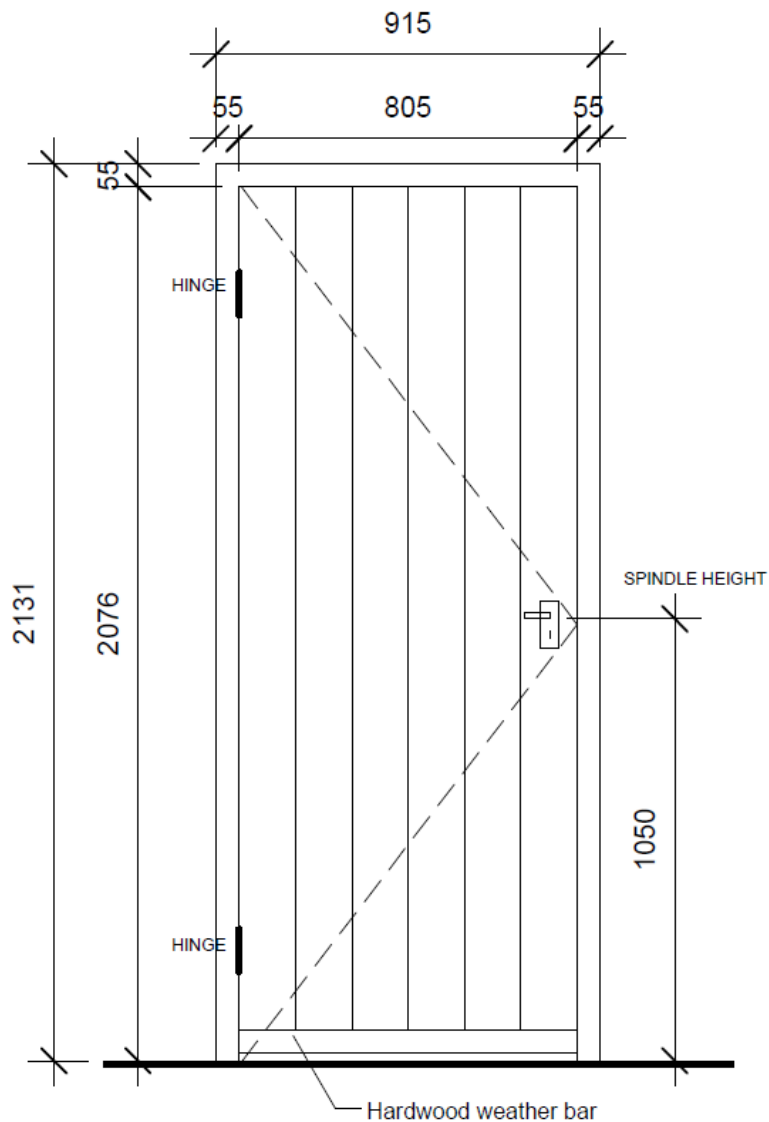

24.5.4 SECURITY GATES:

Security gates will be manufactured as specified on the drawings. Security doors shall be fitted on the wall with the specified frame and fasteners. Gates shall be able to open 180° flush against the wall. The direction of opening shall be according to the layout drawings, and in accordance to the instruction of the engineer on site.

The security gate shall be fitted with a 6-lever security lock, Yale or similar approved. The Rawl bolts will be tacked welded to prevent tampering. The steel shall be clean and rust free. Painted with one coat of red oxide steel primer, and two coats of high quality enamel paint.

24.5.5 PURPOSE MADE SHEEP EXIT DOORS

The animal exit doors to be manufactured as specified on drawings, and fitted flush to inside of wall. To be free of rust, and coated with two coats of red oxide primer. The mechanism to operating smoothly, and lubricated.

24.5.6 STEEL ROLLER SHUTTER DOOR

A heavy duty steel roller door for the opening of 2100 x 2300mm to be fitted flat against surface of opening and consist of curtain, vertical guides and overhead mechanism. The Roller shutter door shall be of Serranda Grande or equal approved manufacture, constructed of galvanized steel components, solid slats of 75mm x 0.6mm, chain operated opening system, with "endless" chain.

24.5.7 WATER TANK, TANK BASE AND PIPING

Two 5000 liter polythene water tanks shall be manufactured from LLDPE, UV stabilized raw materials, and comply with F&DA regulation 177.1520 for food contact application, and carry a minimum five (5) year manufacturer's guarantee. The tank must be supplied with at least a 40mm inlet connector at the top, a 40mm outlet connector at the bottom, and a 450mm lid. The tank must be supplied with a 25mm outlet adaptor at its bottom and connected to roof gutters, securely mounted on the stand.

The tank base shall be constructed as per specifications on the drawing. All specifications applicable under concrete work, and masonry work will apply.

All water installations must be neat and watertight without any leakages and be tested. The stand must be constructed to the specification on the plan to a height of at least 0.6m high. The water tank must be securely tied down and mounted on the stand and must have a 25mm tap.

24.6 PAINT WORK

All painting shall comply to the specifications of Section 16: PAINTING.

Paint colours, and the type of paint used on different elements, must be discussed, and be approved by the Engineer, prior to work commence on paint work.

24.7 ROOFING

All roofing shall comply with Section 8: ROOFING & Section 10: STEEL AND POLYCARBONATE ROOF AND SIDE COVERS, and releant drawings.

Special attention should be given to the specifications of the prefabricated roof trusses, with specific reference to the design and inspection certification thereof.

Payments will be effected in accordance to the quoted payment clauses.

24.8 FENCING

All fence work is based on the specification of a normal vermin proof stock fence, all shall comply with the specifications of Section 19: STOCK FENCE, and the relevant drawings.

24.8.1 LINE POLES

It should be noted, that droppers are replace with a line pole, spaced every 3m, which should consist of an Iron standard, unless otherwise approved by the Engineer.

24.9 ELECTRICAL

All electrical installations shall comply with the specifications of Section 17: ELECTRICAL INSTALLION, and to the relevant drawings. The contractor shall provide the client with a Certificate of Compliance on the electrical installation, as well as "As-built" drawings of the electrical design and distribution board.



NB: Electrical installation specifications will only be applicable in cases where it forms part of the bill of quantities, and drawings.



24.9.1 LUMINARIES (LIGHT FITTINGS)

CODE	ITEM DESCRIPTION	
A1-002	FLUORESCENT CEILING LIGHT	
	BRAND RS Pro RANGE Anti corrosive Fluorescent light CODE 712-6960	
	ITEM DESCRIPTION IP65 High Frequency 230V Non-Corrosive Fluorescent Fitting. Twin batten to fit two x 58 W Fluorescent lamps linear. Dimensions: 1560 x 95 x 100mm	
	COMMENTS All installation as per manufacturer specification	

CODE	ITEM DESCRIPTION	
A1-003	FLOOD LIGHT	
	BRAND RANGE LED 50 W FLOOD LIGHT CODE ULACDFL007	
	ITEM DESCRIPTION Black LED 50W Cool White Flood Light with Motion Sensor.	
	COMMENTS All installation as per manufacturer specification	

24.9.2 LIGHT SWITCHES

CODE	ITEM DESCRIPTION										
A1-005	Flush Light Switch										
	<table border="1"> <tr> <td> <p>BRAND Schneider Electric RANGE S2000 Range CODE S2031_1_2AR_WE</p> </td> <td>  </td> </tr> <tr> <td colspan="2">ITEM DESCRIPTION</td> </tr> <tr> <td colspan="2">Schneider Electric S2000 Range Flush 1 Lever 1 Way Switch</td> </tr> <tr> <td colspan="2">COMMENTS</td> </tr> <tr> <td colspan="2">All installation as per manufacturer specification</td> </tr> </table>	<p>BRAND Schneider Electric RANGE S2000 Range CODE S2031_1_2AR_WE</p>		ITEM DESCRIPTION		Schneider Electric S2000 Range Flush 1 Lever 1 Way Switch		COMMENTS		All installation as per manufacturer specification	
<p>BRAND Schneider Electric RANGE S2000 Range CODE S2031_1_2AR_WE</p>											
ITEM DESCRIPTION											
Schneider Electric S2000 Range Flush 1 Lever 1 Way Switch											
COMMENTS											
All installation as per manufacturer specification											

CODE	ITEM DESCRIPTION										
A1-006	Flush Light Switch										
	<table border="1"> <tr> <td> <p>BRAND Schneider Electric RANGE S2000 Range CODE S2032_1_2AR_WE</p> </td> <td>  </td> </tr> <tr> <td colspan="2">ITEM DESCRIPTION</td> </tr> <tr> <td colspan="2">Schneider Electric S2000 Range Flush 2 Lever 1 Way Switch</td> </tr> <tr> <td colspan="2">COMMENTS</td> </tr> <tr> <td colspan="2">All installation as per manufacturer specification</td> </tr> </table>	<p>BRAND Schneider Electric RANGE S2000 Range CODE S2032_1_2AR_WE</p>		ITEM DESCRIPTION		Schneider Electric S2000 Range Flush 2 Lever 1 Way Switch		COMMENTS		All installation as per manufacturer specification	
<p>BRAND Schneider Electric RANGE S2000 Range CODE S2032_1_2AR_WE</p>											
ITEM DESCRIPTION											
Schneider Electric S2000 Range Flush 2 Lever 1 Way Switch											
COMMENTS											
All installation as per manufacturer specification											

24.9.3 SOCKET OUTLETS

	CODE	ITEM DESCRIPTION	
	A1-004	16A Switched Socket	
		BRAND Schneider Electric RANGE S2000 Range CODE ST2025WE	
		ITEM DESCRIPTION	
		Schneider Electric S2000 Range Double 16A Switched socket	
		COMMENTS	
	All installation as per manufacturer specification		

24.10 ANIMAL HANDLING FACILITIES

All the animal handling facilities are based on pre-fabricated gate sections, and shall comply with the specifications of Section 25: SMALL STOCK ANIMAL HANDLING FACILITIES, and the relevant drawings.

25 SECTION 25: SMALL STOCK ANIMAL PRE-FABRICATED HANDLING FACILITIES

25.1 SCOPE

This specification covers the supply, delivery of pre-fabricated sheep handling facilities.

25.2 PREFABRICATED GATE SECTIONS

25.2.1.1 PREFABRICATED GATE SECTIONS (TALTEC TSK1 OR SIMILAR)



- Prefabricated gate sections shall be Taltec TSK 1 or similar, according to the dimensions in the drawings in the bill of quantities.
- Tube diameter shall be 25.4 mm outside and 19.1mm inside x 3mm thick.
- Painted with 2 layers of grey primer and 2 layer of olive green enamel paint.

25.2.1.2 PREFABRICATED GATE SECTIONS WITH GATE - 1850 X 900MM (TALTEC TSK3 OR SIMILAR)



- Prefabricated gate sections shall be Taltec TSK 3 or similar, according to the dimensions in the drawings in the bill of quantities.
- Tube diameter shall be 25.4 mm outside and 19.1mm inside x 3mm thick.
- Painted with 2 layers of grey primer and 2 layer of olive green enamel paint.

25.2.1.3 PREFABRICATED CRUSH SECTIONS - 1850 X 900MM (TALTEC TSK2 OR SIMILAR)



- Prefabricated crush sections shall be Taltec TSK 2 or similar, according to the dimensions in the drawings in the bill of quantities.
- Tube diameter shall be 25.4 mm outside and 19.1mm inside x 3mm thick.
- Side cover with 1mm sheet metal.
- Painted with 2 layers of grey primer and 2 layer of olive green enamel paint.

25.2.1.4 PREFABRICATED ARCH FRAME FOR CRUSH (TALTEC OR SIMILAR)



- The width and height of the frame shall be at least 0.56m x 1.1m, designed as above.
- Tube diameter shall be 25.4mm for outside tubing (See picture above).
- Painted with 2 layers of grey primer and 2 layer of olive green enamel paint.

25.2.1.5 PREFABRICATED SORTING GATE (TALTEK TSK5 OR SIMILAR)



- The width and height of the sorting gate shall be at least 0.56m x 1.1m, designed as above.
- Tube diameter shall be 25.4mm for outside tubing (See picture above).
- Gate covered with solid sheet metal of at least 1mm thick.
- Painted with 2 layers of grey primer and 2 layer of olive green enamel paint.

25.2.1.6 PREFABRICATED GUILLOTINE GATE (TALTEC TSK4 OR SIMILAR)



- The width and height of the drop gate shall be at least 0.56m x 1.1m, designed as above.

- Tube diameter shall be 25.4mm for outside tubing (See picture above).
- Painted with 2 layers of grey primer and 2 layer of olive green enamel paint.

25.2.1.7 PREFABRICATED STEEL PINS (GATE CONNECTORS) (TALTEC OR SIMILAR)

- The length and width of the steel pin shall be 16mm diameter and 0.80m long with 8cm bend.
- Painted with 2 layers of grey primer and 2 layer of olive green enamel paint.

25.3 FOOT BATH

The footbath supplied shall be a pre-fabricated fibreglass / LLDPE footbath, with the approximate dimensions of 2.4m long x 225mm wide and 425mm high side walls. It shall be a Poldale footbath, or similar approved. The footbath is not a fixture, and must be movable to be placed in sheep crush when required.

PC 25 MEASUREMENT AND PAYMENT

Item	Unit
PC 25.1 Prefabricated gate section.....	Number (No.)

The unit of measurement to supply and deliver the gate sections shall be the number of units as specified.

The tendered rate shall be in full compensation for supply and delivery to site of the complete unit as per the specifications.

Item	Unit
PC 25.2 Foot Bath	Number (No.)

The unit of measurement to supply and deliver the foot bath shall be the number of units as specified.

The tendered rate shall be in full compensation for supply and delivery to site of the complete unit as per the specifications.

26 SECTION 26: SHEARING EQUIPMENT

26.1 SCOPE

This specification covers the supply and delivery of sheep shearing equipment.

26.2 WOOL SORTING TABLE

The wool sorting table shall be specially manufactured with mild steel members, strictly as specified on drawings. The table shall have removable legs. All the ends of hollow members shall be closed off by adding end caps to members. The manufacturer shall take special care to ensure that there is no sharp edges, and that all welding and cutting edges are smoothed.

All mild steel members shall be prepared, and painted as specified in the Painting section, with two one coat of red oxide steel primer, and two coats of aluminium silver solvent based paint.

26.3 PIECE PICKING TABLE

The piece picking table shall be specially manufactured with mild steel members, strictly as specified on drawings. The table shall have removable legs. All the ends of hollow members shall be closed off by adding end caps to members. The manufacturer shall take special care to ensure that there is no sharp edges, and that all welding and cutting edges are smoothed.

All mild steel members shall be prepared, and painted as specified in the Painting section, with one coat of red oxide steel primer, and two coats of aluminium silver solvent based paint.

26.4 WOOL BINS

The wool bins will be manufactured with mild steel members, according to specifications on drawings. The wool bins shall be collapsible, and interlinked. Wool bins will be covered with 50 x 50mm wire mesh, or diamond mesh. The manufacturer shall take special care to ensure that there is no sharp edges, and that all welding and cutting edges are smoothed.

All mild steel members shall be prepared, and painted as specified in the Painting section, with one coat of red oxide steel primer, and two coats of aluminium silver solvent based paint.

26.5 WOOL BASKETS

The wool baskets shall be manufactured with mild steel members, according to specifications on drawings. Wool bins shall be fitted with four industrial type, swivel bearing casters on each corner, with a wheel diameter of at least 50mm. The manufacturer shall take special care to ensure that there is no sharp edges, and that all welding and cutting edges are smoothed.

All mild steel members shall be prepared, and painted as specified in the Painting section, with one coat of red oxide steel primer, and two coats of aluminium silver solvent based paint.

26.6 BALE LIFTING HOOKS

Bale lifting hooks shall be manufactured with 12mm mild steel round bar, bent and shaped as shown on drawing.

All mild steel members shall be prepared, and painted as specified in the Painting section, with one coat of red oxide steel primer, and two coats of aluminium silver solvent based paint.

26.7 SHEARING BOARDS

Shearing boards shall be manufactured of treated SA Pine grade 5 wood as specified on drawing. Member shall be attached with 50mm wood screws, counter sunk with no sharp extrusions. The boards will be sanded to a smooth finish, and all corners rounded to prevent injury to the animals.

26.8 SINGLE BASE GEAR WOOL PRESS

A mechanical single base wool press, pre-approved by the engineer shall be supplied. The wool press shall be durable be fitted with heavy duty industrial casters to assist with moving the instrument. The press mechanism shall be heavy duty, with a minimum thrust of 5 tons on the plunger and operating smoothly. The system shall be such that it can be operated by one person.

The wool rack shall be at least 1,2m high and 700 x 700mm in width with hooks to attach wool bags. The wool rack shall be easily collapsible to assist with the removal of the bale. Side panels of the wool rack, shall be manufactured with W-shaped steel panels of not less than 2,5mm thickness.

The wool press shall be South African manufactured. The wool press shall have a one year defects guarantee, and the manufacturer shall be able to provide a after sales service within 5 working days, for the repair of defects.

The wool press shall be coated with at least one coat of red oxide steel primer, and two coats of high quality enamel paint.

26.9 WOOL SCALE

The wool scale shall be an industrial mechanical, movable (trolley), platform scale. The platform shall be at least 600 x 400mm or larger. The scale shall have a minimum weighing capacity of 250kg, weighing in minimum steps of 200g.

26.10 SHEEP SHEARS

The sheep shears shall be manual hand shears, shall be manufactured of high quality carbon steel, and shall be "Drummerboy 160mm(No.10)" shears, or similar approved.

26.11 DIP HOOK AND STAFF

The dip hook and staff shall be manufactured from 12mm mild steel round bar, bent and shaped as specified in the drawings. Care must be taken that ends are properly rounded with no sharp edges. The handle shall be manufactured of Eucalyptus wood and 2m in length, and securely attached to hook.

All mild steel members shall be prepared, and painted as specified in the Painting section, with one coat of red oxide steel primer, and two coats of aluminium silver solvent based paint.

26.12 DEMONSTRATION OF EQUIPMENT

The suppliers shall on delivery of the equipment, conduct a demonstration session during which selected members of the community will be trained in the operation of all the equipment supplied. The supplier shall demonstrate the assembly, dismantling, adjusting and operation of all the equipment. The suppliers shall further train the community members on the maintenance of the equipment, and operational safety. The constructor supply all manuals and guarantees to the community liaison offices, and keep an attendance register of the members attending the demonstration session.

PC 26 MEASUREMENT AND PAYMENT

Item		Unit
PC 26.1	Shearing Equipment	Number (No.)

The unit of measurement to supply and deliver the shearing equipment shall be the number of units as specified.

The tendered rate shall be in full compensation for supply and delivery to site of the complete unit as per the specifications.

Item		Unit
PC 26.2	Demonstration of Equipment	Sum

The unit of measurement for demonstrate and train the beneficiaries shall be in a sum.

The tendered rate shall be in full compensation for transport, materials, and time related items for the training of beneficiaries on the use and maintenance of the equipment as specified.

27 SECTION 27: PIT TOILET

27.1 SCOPE

This specification covers the supply, delivery and construction of a pit toilet.

27.2 EARTH WORKS

All Earth Works for Site Clearance, General Earth Works and Earth Works for pipelines shall comply with the specifications as set out in Section 2: Earth Works and also to SANS 2001 – Construction Works Part BS1: Site clearance; SANS 2001 – Construction Works Part BE1: Earth Works (general) and SANS 2001-DP1 Construction Works. Part DP1: Earth Works for buried pipelines and prefabricated culverts.

Payment for Earth Works will be as set out in the relevant Measurement and Payment Clause for this section.

27.2.1 SAFETY

27.2.1.1 BARRICADING AND LIGHTING

In terms of the applicable regulation of the Machinery and Occupational Safety Act, 1983 (Act 6 of 1983), every excavation that is accessible to the public or that is adjacent to a public road or thoroughfare or by which the safety of persons may be endangered, shall be adequately protected by a barrier or fence of height at least 1 000 mm and as close to the excavation as practicable.

27.2.1.2 STORM WATER AND GROUNDWATER.

The Contractor shall properly deal with and dispose of water to ensure that the works are kept sufficiently dry for their proper execution. His responsibility will be held to include the provision of adequate protection against flooding and damage by storm water, flow from springs, and seepage, and to include provision for the repair, at his expense, of any damage to the works that may arise as a result of the inadequacy of the protection provided by him. Except where the use of tremies has been approved, foundation excavations for structures shall be kept free from water at all times until they have been inspected and approved and concrete footings have been cast.

27.2.1.3 EXCAVATED MATERIAL NOT TO ENDANGER OR INTERFERE.

All excavated material shall be so deposited as not to interfere with or endanger the works (for example, by causing the sides of an excavation to collapse), other property or traffic. The Engineer may order the Contractor to remove any material that the Engineer considers liable to endanger or to interfere with the works, private property, traffic or pedestrians, and to place such material at some other approved location. If the necessity for such removal is, in the opinion of the Engineer, a result of some fault on the part of the Contractor, the cost of removal shall be borne by the Contractor, but otherwise it will be borne by the Employer. All material that is unsuitable or not required for backfilling shall be removed from the site and spread, as ordered, on areas designated by the Engineer.

27.2.1.4 PROTECTING LIVESTOCK

From the time of the site being handed over to the Contractor up to the date of the completion certificate being issued to the contractor, he shall take all measures necessary for preventing the ingress of vermin, and of protecting and controlling livestock, etc. on the sections of the properties affected by his operations. He shall provide gates at the positions in existing fences cut by him for gaining access and shall ensure that all gates are kept closed except when they

are opened for admitting his traffic. No fences shall be cut without the approval of the engineer, and consultation with the owner of the fence.

Where alternative arrangements cannot be made, the engineer may direct the contractor to erect temporary fencing where necessary to protect livestock that may be lost or are exposed to vermin through his operations. Such fencing shall be of an adequate standard and shall be erected ahead of construction operations. The fencing shall be maintained in a good order during construction operations and, on completion of the work, it shall be removed from the site and all surfaces shall be restored. The engineer may order that any permanent fencing which is required erected up ahead of construction operations, where practicable, in lieu of erecting temporary fencing.

Payment for the protection of livestock, excluding the erection of temporary fences, shall be included in the amounts tendered for the contractor's establishment on the site.

27.3 CONCRETE WORKS

All Concrete, Formwork and Reinforcement shall comply to the specifications of Section 3: CONCRETE, FORMWORK AND REINFORCEMENT, and the relevant drawings and bill of quantities.

27.3.1 FORMWORK

All formwork will be executed according to the relevant specifications of Section 3. Formwork shall be approved by the Engineer, prior to any pouring of concrete will be allowed.

27.3.2 REINFORCEMENT OF PIT TOILET SLAB

Reinforcement shall be 10mm mild steel round bar, 100mm coc placed in two layers in the slab, with 50mm cover at the bottom and top of the slab, as indicated in the relevant drawings.

27.3.3 READY MIX CONCRETE

All concrete elements shall be executed with ready mix concrete, unless otherwise instructed by the Engineer.

The contractor shall take care to order ready mix concrete to the correct specifications for the specific element, and manageable quantities, in order to pour, place and finish while the concrete is workable.

27.3.4 CURING AND PROTECTION.

After formwork has been removed and as soon as it is practicable in the opinion of the Engineer, all concrete shall be protected from contamination and loss of moisture by one or more of the following methods:

- Ponding the exposed surfaces by means of water except under cold weather conditions (concrete surfaces shall not be wet intermittently by spraying or otherwise).
- Covering the concrete with sand or mats made of moisture retaining material, and keeping the covering continuously wet
- The use of an approved curing compound applied in accordance with the manufacturer's instructions. The curing period shall be at least 5days for the concrete made with Portland cement, at least 2days for concrete made with rapid – hardening Portland cement, and at least 7days if Portland blast furnace cement is used. When atmospheric temperature is below 5°C, these minimum curing periods shall be extended by 72hours, 36hours, and 72hours respectively.

27.3.5 DEFECTS.

The concrete shall be homogenous and free from honeycombing, interstices and planes of weakness. If, after the removal of the forms, the concrete shows any defect, the Contractor

shall immediately report such defect to the Engineer, and shall not carry out any patching or remedial work until authorized to do so by the Engineer.

After thorough inspection and investigation of the quality and strength of the defective work and after due consideration of the possible consequences of such defect, the Engineer will either specify the extent and method of repair, or order the demolition and reconstruction of the whole of the defective work to the extent which he considers necessary.

The cost of all such investigation, repair and remedial work and of any demolition and reconstruction of defective work shall be borne by the Contractor and all repair, remedial and reconstruction work shall be executed to the satisfaction of the Engineer.

27.4 MASONRY WORKS

All masonry work shall comply to the specification of SECTION 4: MASONRY, and the relevant drawings.

27.4.1 BRICK WORK

All brick work shall be executed with burnt clay bricks, as specified in Section 4.

27.4.2 BRICK REINFORCING

Unless otherwise described, brick work reinforcement is to of approved SA manufactured welded high-tensile steel wire reinforcing fabric of the width stated, cut to length and lapped full width at corners and passing. Rate shall be included in the rate of brick and block work, built into walls at every third layer.

27.5 DOORS AND FITTINGS

All windows, doors and fittings shall comply to the specifications of:

- SECTION 7: METALWORK
- SECTION 11: JOINERY
- SECTION 12: IRONMONGARY
- SECTION 14: INSTALLTION OF GLAZING IN WINDOWS

And specifications of relevant drawings.

27.5.1 DOOR FRAMES

Door frames shall be Durowin steel frames or equally approved. Door size of 2078 x 805mm. Each frame shall have 4 x 300mm galvanized hoop iron building in lugs per frame style. It must be factory primed red oxide, and damaged areas touched-up and painted with red-oxide steel primer.

Apply two coats of high quality gloss enamel paint. Colour to be agreed with the Engineer.

27.5.2 HARDWOOD DOORS

Door to be 2076x805x44mm, selected red meranti. Framed ledged, framed and battered door with 8mm smooth rempered hardwood flush internal panelling.

108 x44mm top rails and styles. 220 x 20mm lock rail and bottom rail.

Standard 70x44mm hardwood weather bar fitted to bottom edge.

Apply three coats of high quality, clear external varnish.

Upper edge cylinder Como door lock, code BP 8100.

Yale night hatch Y3 – Satin Chrome model P-85-SC-40.

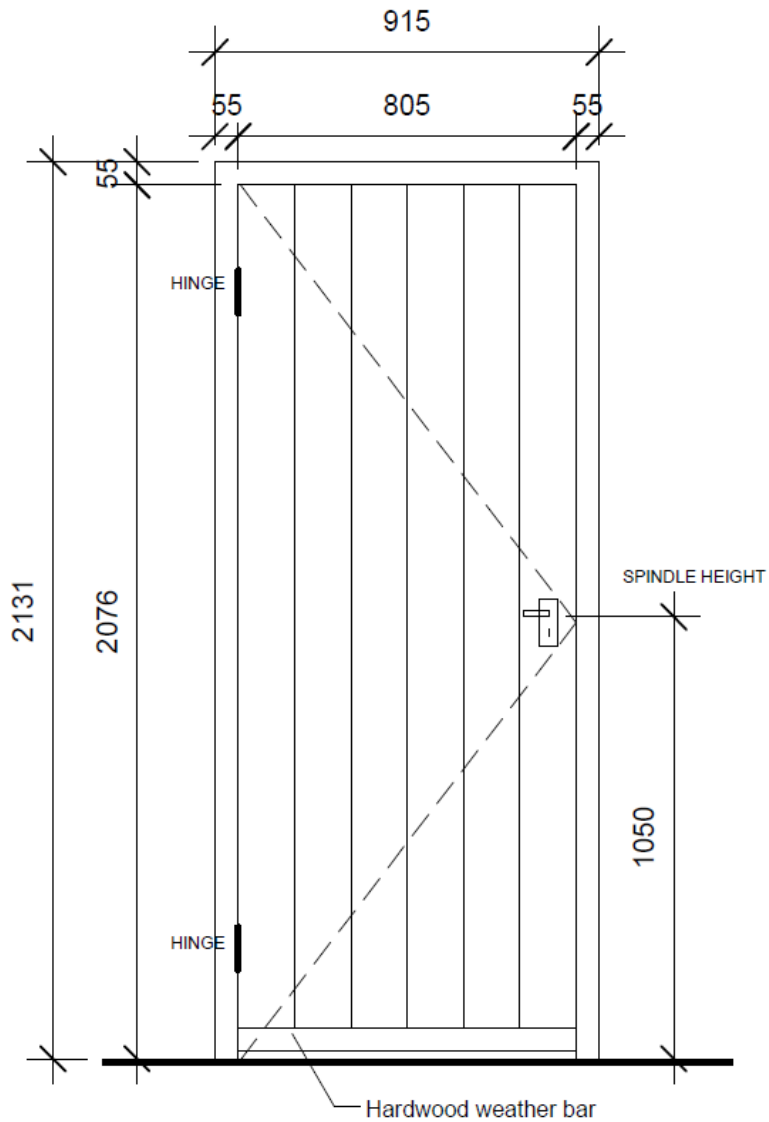

27.5.3 PEDESTAL

The toilet pedestal shall be a Jo-Jo VIP450, high quality LDPE pedestal and seat, on similar approved by the engineer. The pedestal shall be manufactured from virgin products, UV resistant and carry a 10 year guarantee. The pedestal shall be secured and fitted strictly according to the manufacturer's instructions.

SIDE VIEW

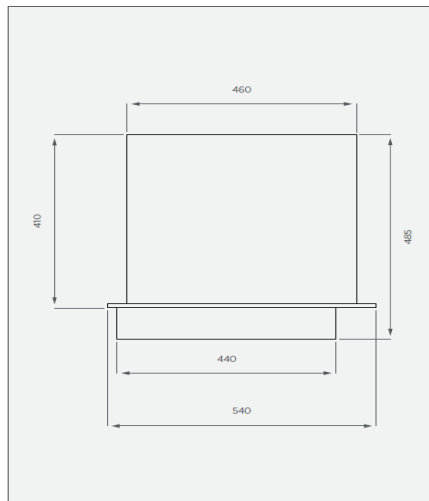

TOP VIEW

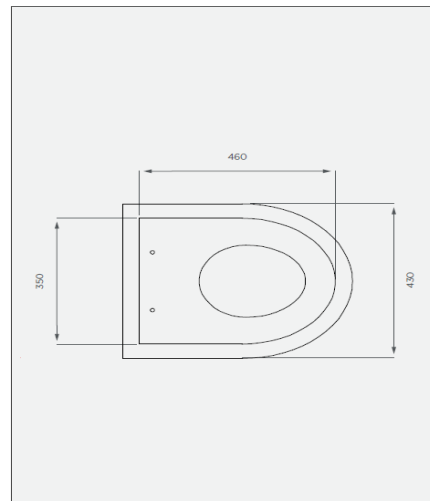

27.5.4 VENTILATION PIPE

The ventilation pipe shall consist of a 110mm PVC pipes and fittings, UV protected and complying to the relevant SANS specifications. The pipe shall be secured to the back of the toilet building, securely fitted and sealed in the concrete slab. The pipe shall be black, or painted black in order to improve airflow.

27.6 PAINT WORK

All painting shall comply to the specifications of Section 16: PAINTING.

Paint colours, and the type of paint used on different elements, must be discussed, and be approved by the Engineer, prior to work commence on paint work.

27.7 ROOFING

All roofing shall comply with Section 8: ROOFING & Section 10: STEEL AND POLYCARBONATE ROOF AND SIDE COVERS, and relevant drawings.

Special attention should be given to the specifications of the prefabricated roof trusses, with specific reference to the design and inspection certification thereof.

Payments will be effected in accordance to the quoted payment clauses.

PC 27 MEASUREMENT AND PAYMENT

Item	Unit
PC 27.1 Roof structure	Sum

The unit of measurement for the supply and erection of the pit toilet roof is a sum.

The tendered rate shall be in full compensation for supply and erection of the roof structure, including timber, roof sheeting, fascia boards, and labour to erect the roof structure of the pit toilet.

28 SECTION 28: SHEEP PLUNGE DIP TANK AND EVAPORATION POND

28.1 SCOPE

This specification covers the supply, delivery and construction of sheep plunge dip tank.

28.2 SUPPORTING SPECIFICATIONS

The specification shall be read in conjunction with the following latest issues of the following standards published by the South African Bureau of Standards.

SABS 1200 AA "General"

28.3 EARTH WORKS

All Earth Works for Site Clearance, General Earth Works and Earth Works for pipelines shall comply with the specifications as set out in Section 2: Earth Works and also to SANS 2001 – Construction Works Part BS1: Site clearance; SANS 2001 – Construction Works Part BE1: Earth Works (general) and SANS 2001-DP1 Construction Works. Part DP1: Earth Works for buried pipelines and prefabricated culverts.

Payment for Earth Works will be as set out in the relevant Measurement and Payment Clause for this section.

28.3.1 SAFETY

28.3.1.1 BARRICADING AND LIGHTING

In terms of the applicable regulation of the Machinery and Occupational Safety Act, 1983 (Act 6 of 1983), every excavation that is accessible to the public or that is adjacent to a public road or thoroughfare or by which the safety of persons may be endangered, shall be adequately protected by a barrier or fence of height at least 1 000 mm and as close to the excavation as practicable.

28.3.1.2 STORM WATER AND GROUNDWATER.

The Contractor shall properly deal with and dispose of water to ensure that the works are kept sufficiently dry for their proper execution. His responsibility will be held to include the provision of adequate protection against flooding and damage by storm water, flow from springs, and seepage, and to include provision for the repair, at his expense, of any damage to the works that may arise as a result of the inadequacy of the protection provided by him. Except where the use of tremies has been approved, foundation excavations for structures shall be kept free from water at all times until they have been inspected and approved and concrete footings have been cast.

28.3.1.3 EXCAVATED MATERIAL NOT TO ENDANGER OR INTERFERE.

All excavated material shall be so deposited as not to interfere with or endanger the works (for example, by causing the sides of an excavation to collapse), other property or traffic. The Engineer may order the Contractor to remove any material that the Engineer considers liable to endanger or to interfere with the works, private property, traffic or pedestrians, and to place such material at some other approved location. If the necessity for such removal is, in the opinion of the Engineer, a result of some fault on the part of the Contractor, the cost of removal

shall be borne by the Contractor, but otherwise it will be borne by the Employer. All material that is unsuitable or not required for backfilling shall be removed from the site and spread, as ordered, on areas designated by the Engineer.

28.3.1.4 PROTECTING LIVESTOCK

From the time of the site being handed over to the Contractor up to the date of the completion certificate being issued to the contractor, he shall take all measures necessary for preventing the ingress of vermin, and of protecting and controlling livestock, etc. on the sections of the properties affected by his operations. He shall provide gates at the positions in existing fences cut by him for gaining access and shall ensure that all gates are kept closed except when they are opened for admitting his traffic. No fences shall be cut without the approval of the engineer, and consultation with the owner of the fence.

Where alternative arrangements cannot be made, the engineer may direct the contractor to erect temporary fencing where necessary to protect livestock that may be lost or are exposed to vermin through his operations. Such fencing shall be of an adequate standard and shall be erected ahead of construction operations. The fencing shall be maintained in a good order during construction operations and, on completion of the work, it shall be removed from the site and all surfaces shall be restored. The engineer may order that any permanent fencing which is required erected up ahead of construction operations, where practicable, in lieu of erecting temporary fencing.

Payment for the protection of livestock, excluding the erection of temporary fences, shall be included in the amounts tendered for the contractor's establishment on the site.

28.3.2 COMPACTED FILLING MATERIAL SUPPLIED BY THE CONTRACTOR

28.3.2.1 GRAVEL DRESSING OF CONSOLIDATED 75MM THICKNESS

Gravel cover on terrain will be executed with imported G5 material dry earth, free from clay and spread evenly in layers, well compacted to a minimum thickness of 75mm.

28.4 CONCRETE WORKS

All Concrete, Formwork and Reinforcement shall comply to the specifications of Section 3: CONCRETE, FORMWORK AND REINFORCEMENT, and the relevant drawings and bill of quantities.

28.4.1 FORMWORK

All formwork will be executed according to the relevant specifications of Section 3. Formwork shall be approved by the Engineer, prior to any pouring of concrete will be allowed.

28.4.2 REINFORCEMENT OF DIP TANK

Hightenstile steel mesh, Ref 395 will be place in a double layer in centre of the walls and slab. It will be bind together in such a manner to half the spacing between members, and approved by the Engineer, before concrete is poured.

28.4.3 WATER TIGHT CONCRETE.

The dipping tank and dripping pen floor shall be water tight. Special care shall be taken by the Contractor to ensure water tightness, particularly at the construction joints. Should any such section of the dipping tank and dripping pen floor, show any sign of water leakage or penetration after being taken into use, it shall be deemed defective.

28.4.4 READY MIX CONCRETE

All concrete elements shall be executed with ready mix concrete, unless otherwise instructed by the Engineer.

The contractor shall take care to order ready mix concrete to the correct specifications for the specific element, and manageable quantities, in order to pour, place and finish while the concrete is workable.

28.4.5 CURING AND PROTECTION.

After formwork has been removed and as soon as it is practicable in the opinion of the Engineer, all concrete shall be protected from contamination and loss of moisture by one or more of the following methods:

- Ponding the exposed surfaces by means of water except under cold weather conditions (concrete surfaces shall not be wet intermittently by spraying or otherwise).
- Covering the concrete with sand or mats made of moisture retaining material, and keeping the covering continuously wet
- The use of an approved curing compound applied in accordance with the manufacturer's instructions. The curing period shall be at least 5days for the concrete made with Portland cement, at least 2days for concrete made with rapid – hardening Portland cement, and at least 7days if Portland blast furnace cement is used. When atmospheric temperature is below 5°C, these minimum curing periods shall be extended by 72hours, 36hours, and 72hours respectively.

28.4.6 DEFECTS.

The concrete shall be homogenous and free from honeycombing, interstices and planes of weakness. If, after the removal of the forms, the concrete shows any defect, the Contractor shall immediately report such defect to the Engineer, and shall not carry out any patching or remedial work until authorized to do so by the Engineer.

After thorough inspection and investigation of the quality and strength of the defective work and after due consideration of the possible consequences of such defect, the Engineer will either specify the extent and method of repair, or order the demolition and reconstruction of the whole of the defective work to the extent which he considers necessary.

The cost of all such investigation, repair and remedial work and of any demolition and reconstruction of defective work shall be borne by the Contractor and all repair, remedial and reconstruction work shall be executed to the satisfaction of the Engineer.

28.5 FENCING

All fence work is based on the specification of a normal vermin proof stock fence, all shall comply with the specifications of Section 19: STOCK FENCE, and the relevant drawings.

28.5.1 LINE POLES

It should be noted, that droppers are replace with a line pole, spaced every 3m, which should consist of an Iron standard, unless otherwise approved by the Engineer.

29 SECTION 29: SMALL STOCK HANDLING FACILITY

29.1 SCOPE

This section covers the erection of a small stock handling facility.
The contract period is 2 months, during which no CPA is applicable.

29.2 SUPPORTING SPECIFICATIONS

The specification shall be read in conjunction with the latest issues of the standards published by the South African Bureau of Standards, as per the relevant sections.

29.3 MATERIALS AND DIMENSIONS

29.3.1 CORNER-, STRAINING-, ANCHOR-, GATE POSTS AND BRACES:

Corner-, Straining-, Anchor-, Gate Posts and Braces shall be as per SECTION 19: STOCK FENCES.

29.3.2 STANDARDS:

Standards shall be as per SECTION 19: STOCK FENCES.

29.3.3 DROPPERS:

Droppers shall be timber droppers and be treated with a preservative in accordance with the requirements of SABS 1288 (Preservative treated timber) or SABS 05 (Creosote treated timber).

29.3.4 WIRE:

Wire shall be as per specifications in SECTION 19: STOCK FENCES. (4,00mm diameter fully galvanised zinc-coated mild steel wire)

29.3.5 WIRE NETTING:

Wire netting shall be as per specifications in 19: STOCK FENCES. (Fully galvanized mild-steel wire with a minimum diameter of 1,8 mm, with 75 mm hexagonal mesh)
The width shall be as shown on the drawings.

29.3.6 GATES:

Gates shall be manufactured to the dimensions and details shown on the drawings. Gates shall be manufactured of mild steel tubing having continuously welded seams.

The frame shall be of tubing of bore 32 mm and wall thickness of 2,0 mm in the case of main frame members, and of a bore 22 mm and wall thickness of 2,0 mm in the case of bracing members. The width of each gate shall be as shown on the drawings.

Gates shall be complete in every respect, including hinges, washers, bolts and locking chains attached to the gate.

Gates shall be zinc-coated as specified in SABS 763 for class B1 articles.

29.3.7 STEEL:

The steel poles must have a 63 mm diameter and a steel thickness of 3,0 mm. The steel poles shall be manufactured to the lengths and spacing as shown on the drawings.

In the race, an angle iron of 50 mm x 50 mm x 5 mm must be welded between the steel poles.

Poles and the angle iron shall be painted 2 layers with anti-corrosion paint and 1 layer of grade 1 aluminum paint.

All steel must be of grade 300W steel.

29.4 CONSTRUCTION:

29.4.1 CLEARING THE FENCE LINE:

Clearing of the fence line will be as per specifications in 19: STOCK FENCES.

29.4.2 POSTS:

A post shall have no damaged marks on it and shall not be cut to length after it was treated with a preservative chemical or creosote.

29.4.3 BRACES:

Braces shall have no damaged marks on it and shall not be cut to length after it was treated with a preservative chemical or creosote.

29.4.4 MEANS FOR ATTACHING FENCING WIRES TO POSTS, STANDARDS AND DROPPERS:

Means for attaching fencing wires to posts, standards and droppers will be as per specifications in SECTION 19: STOCK FENCES.

29.4.5 UNROLLING AND TENSIONING OF FENCING WIRES:

Unrolling and tensioning of fencing wires will be as per specification in SECTION 19: STOCK FENCES.

29.4.6 GATES:

Gates will be as per specifications in SECTION 19: STOCK FENCES.

29.4.7 CLOSING OPENINGS UNDER FENCES:

Closing of openings under fences will be as per specifications in SECTION 19: STOCK FENCES.

29.5 EXISTING FENCES

Existing fences will be dealt with according to specifications in SECTION 19: STOCK FENCES.

29.6 REQUIREMENTS FOR THE FENCE

29.6.1 DESIGN:

29.6.1.1 GENERAL:

See SECTION 19: STOCK FENCES.

29.6.1.2 SIZE OF FENCE:

The height, from the ground level to the top of the fence, shall be the appropriate height as specified on the drawings:

- Race and Loading Race - 900mm
- Kraal Fence - 1200mm

The length of the fence shall be as specified on the drawings.

29.6.1.3 FENCING WIRES:

The fencing wires shall be at spacings shown on the drawings. The type of plain high tensile steel wire shall be as shown on the drawing or as directed by the Engineer.

29.6.1.4 GATES:

The number of gates and sizes shall be as specified on the drawings.

29.6.2 ERECTION:

29.6.2.1 POSTS:

Corner posts shall be provided at all corners and other changes in direction. Anchor posts shall be provided at acute variations in the level of the fence and gate posts shall be provided as support at all gates.

29.6.2.2 STANDARDS AND DROPPERS:

The following spacings of standards and droppers will apply to the kraal fences:

- b) Standards 2.5m from the anchor post with 2 droppers in between

The following spacings of standards and droppers will apply the race and loading race:

- c) Standards 925mm from the steel pipe with one dropper in between.

29.6.2.3 BRACES:

Corner Posts shall be a combination of two box anchors and therefore be provided with two braces, of 1 800 mm in length, shall be fixed to the corner post and anchors as shown on the drawings or as directed by the Engineer. Anchor-, Straining- and Gate posts shall have one brace, of 1 800 mm in length and shall be fixed to each post as shown on the drawings or as directed by the Engineer.

29.6.2.4 FENCE WIRES:

Fencing wires shall be parallel. Each fence wire shall be twisted at least two times around a straining post. The free end of the wire shall be twisted at least six times around the wire. The fencing wire shall be secured to each standard and dropper by a tie wire.

29.6.2.5 WIRE NETTING:

The wire netting shall, after being suitably tensioned to ensure that the wire netting is straight in all directions, be attached by tie wires to the fence wires. The positions of attachment shall be as follows:

- 4) To the top fence wire as shown on the drawings that will hold the wire netting in position: at distances not more than 150 mm apart.
- 5) To the bottom fence wire: at distances not more than 150 mm apart.
- 6) To the intermediate fence wires: at distances not more than 300 mm apart.

In addition, the wire netting shall be attached to each straining post by means of tie wires taken around the post at distances of 150 mm.

29.6.2.6 GATES:

Gates shall be so erected that:

- a) There is a gap of not less than 25 mm and not more than 50 mm between the hinge stile(s) and the straining posts;
- b) There is clearance of not less than 50 mm and not more than 75 mm between the bottom horizontal frame member(s) and the ground; and
- c) When closed, there is a space of not more than 25 mm between the closing stile and the straining post in the case of single-leaf gates.

29.7 WORKMANSHIP

29.7.1 POSTS:

All posts shall be rigid and sturdy, set well into the ground and be well anchored. The narrower a post fits into the hole, i.e. the less the fill round the side of the post, the greater the resistance of the post. The hole for a pole should not be of greater diameter than 450mm where it is planted directly into the soil. Soil must be carefully backfilled with soil in layers of 150 mm maximum thickness and well compacted. Under wet conditions, it is recommended that the hole be filled with drier soil which in turn is compacted better.

29.7.2 STANDARDS AND DROPPERS:

All standards shall be driven into the ground to a maximum depth of 600 mm. Standards must be sturdy and preferably driven in the ground with a Post driver.

29.7.2 WIRES:

Fence wires shall be taut, and securely fastened to the posts.

29.7.3 WIRE NETTING:

The wire netting shall be sufficiently tensioned to ensure that the wire netting is uniform, and it shall be securely fastened.

29.7.4 GATES:

Gates shall have no noticeable twist or sag. When the gates are closed, the closing stiles shall be parallel in the case of double-leaf gates, or the closing stile shall be parallel to the adjacent straining post in the case of single-leaf gates. Gates shall move freely on their hinges. Hasps and staples shall be in correct alignment and operate freely. In the case of double-leaf gates, the drop bolts shall operate freely.

29.7.5 BRACES:

All braces shall be secure to the posts with a 10 mm diameter iron rod hammered into a hole drilled specifically for that purpose and then secured with 4 mm diameter galvanized mild steel wired.

PC 29 MEASUREMENT AND PAYMENT

Item	Unit
29.8.1 <u>SITE CLEARANCE</u>	

Measurement & payment will be according to the relevant section.

29.8.2 EXCAVATION

Measurement & payment will be according to the relevant section.

29.8.3 CONCRETE

Measurement & payment will be according to the relevant section.

Item	Unit
29.8.4 <u>SUPPLY & CONSTRUCT KRAAL- & RACE FENCES</u>	

Supply and construct 1,2 m high new kraal fence(m)

Supply and construct 0,9 m high new race fence(m)

The unit of measurement for erecting the fence shall be the metre of fence measured as indicated on the drawings.

The tendered rate and price paid shall be in full compensation for providing all standards, droppers, fence- and tie wire, wire netting including tying wire and staples for putting up the fence as specified and as shown on the drawings inclusive of all excavations and drilling required with pneumatic tools for holes for the standards or droppers

29.8.5 CORNER-, STRAINING- ANCHOR POSTS -AND GATE POSTS

Measurement & payment will be according to the relevant section.

29.8.6 GATES (SIZE AND TYPE AS INDICATED)

Work involving gates will be measured by number.....No.

The rate shall cover the cost of offloading the material from the vehicles on site, stacking in a designated area, moving from such area, erection, aligning, provision of erection equipment, temporary supports, safety measures, and supplying the material for the gates and stopper arms. The rate shall further cover the cost of access and supply, cutting of the elements and welding for gates, including the supply of consumables and equipment for the cleaning up of mould from bad stalked poles.

Item

Unit

29.8.7 STEEL POLES

Steel Poles (size and type as indicated) number (No)

The unit of measurement for erecting steel poles shall be an extra-over for the number of poles within the race and loading race.

The tendered rate shall be in full compensation for provisioning all materials including all concrete for the welding of the angle iron, the painting, the wire, for excavating or drilling of holes, for erecting the poles as specified and shown on the drawings.

29.8.8 ANGLE IRON

Angle Iron (50mm x 50mm x 5mm) meter (m)

30 SECTION 30: LARGE STOCK HANDLING FACILITY

30.1 SCOPE

This section covers the design, drawings, supply of all material and the construction of Large stock handling facility for agricultural purposes and toilet as indicated on the drawings or as directed by the Engineer.

The contract period is four months, during which no CPA is applicable.

30.2 SUPPORTING SPECIFICATIONS

The specification shall be read in conjunction with the following latest issues of standards as published by the South African Bureau of Standards:

SANS 135: ISO Metric Black Bolts, Screws & Nuts
CKS 264: Flat Mild Steel Washers

30.3 EARTH WORKS

All Earth Works for Site Clearance, General Earth Works and Earth Works for pipelines shall comply with the specifications as set out in SECTION 2: EARTH WORKS and also to SANS 2001 – Construction Works Part BS1: Site clearance; SANS 2001 – Construction Works Part BE1: Earth Works (general) and SANS 2001-DP1 Construction Works. Part DP1: Earth Works for buried pipelines and prefabricated culverts.

Payment for Earth Works will be as set out in the relevant Measurement and Payment Clause for this section.

30.3.1 SAFETY

30.3.1.1 Barricading and Lighting

In terms of the applicable regulation of the Machinery and Occupational Safety Act, 1983 (Act 6 of 1983), every excavation that is accessible to the public or that is adjacent to a public road or thoroughfare or by which the safety of persons may be endangered, shall be adequately protected by a barrier or fence of height at least 1 000 mm and as close to the excavation as practicable.

30.3.1.2 Storm Water and Groundwater.

The Contractor shall properly deal with and dispose of water to ensure that the works are kept sufficiently dry for their proper execution. His responsibility will be held to include the provision of adequate protection against flooding and damage by storm water, flow from springs, and seepage, and to include provision for the repair, at his expense, of any damage to the works that may arise as a result of the inadequacy of the protection provided by him. Except where the use of tremies has been approved, foundation excavations for structures shall be kept free from water at all times until they have been inspected and approved and concrete footings have been cast.

30.3.1.3 Excavated Material Not to Endanger or Interfere.

All excavated material shall be so deposited as not to interfere with or endanger the works (for example, by causing the sides of an excavation to collapse), other property or traffic. The Engineer may order the Contractor to remove any material that the Engineer considers liable to endanger or to interfere with the works, private property, traffic or pedestrians, and to place such material at some other approved location. If the necessity for such removal is, in the opinion of the Engineer, a result of some fault on the part of the Contractor, the cost of removal shall be borne by the Contractor, but

otherwise it will be borne by the Employer. All material that is unsuitable or not required for backfilling shall be removed from the site and spread, as ordered, on areas designated by the Engineer.

30.3.1.4 PROTECTING LIVESTOCK

From the time of the site being handed over to the Contractor up to the date of the completion certificate being issued to the contractor, he shall take all measures necessary for preventing the ingress of vermin, and of protecting and controlling livestock, etc. on the sections of the properties affected by his operations. He shall provide gates at the positions in existing fences cut by him for gaining access and shall ensure that all gates are kept closed except when they are opened for admitting his traffic. No fences shall be cut without the approval of the engineer, and consultation with the owner of the fence.

Where alternative arrangements cannot be made, the engineer may direct the contractor to erect temporary fencing where necessary to protect livestock that may be lost or are exposed to vermin through his operations. Such fencing shall be of an adequate standard and shall be erected ahead of construction operations. The fencing shall be maintained in a good order during construction operations and, on completion of the work, it shall be removed from the site and all surfaces shall be restored. The engineer may order that any permanent fencing which is required erected up ahead of construction operations, where practicable, in lieu of erecting temporary fencing.

Payment for the protection of livestock, excluding the erection of temporary fences, shall be included in the amounts tendered for the contractor's establishment on the site.

30.3.2 GRAVEL DRESSING OF CONSOLIDATED 75MM THICKNESS

Gravel cover on terrain will be executed with imported G5 material dry earth, free from clay and spread evenly in layers, well compacted to a minimum thickness of 75mm.

30.4 CONCRETE WORKS

All Concrete, Formwork and Reinforcement shall comply to the specifications of SECTION 3: CONCRETE, FORMWORK AND REINFORCEMENT, and the relevant drawings and bill of quantities.

30.4.1 FORMWORK

All formwork will be executed according to the relevant specifications of SECTION 3. Formwork shall be approved by the Engineer, prior to any pouring of concrete will be allowed.

30.4.2 READY MIX CONCRETE

All concrete elements shall be executed with ready mix concrete, unless otherwise instructed by the Engineer.

The contractor shall take care to order ready mix concrete to the correct specifications for the specific element, and manageable quantities, in order to pour, place and finish while the concrete is workable.

30.4.3 CURING AND PROTECTION

After formwork has been removed and as soon as it is practicable in the opinion of the Engineer, all concrete shall be protected from contamination and loss of moisture by one or more of the following methods:

- Ponding the exposed surfaces by means of water except under cold weather conditions (concrete surfaces shall not be wet intermittently by spraying or otherwise).

- Covering the concrete with sand or mats made of moisture retaining material, and keeping the covering continuously wet
- The use of an approved curing compound applied in accordance with the manufacturer's instructions. The curing period shall be at least 5days for the concrete made with Portland cement, at least 2days for concrete made with rapid – hardening Portland cement, and at least 7days if Portland blast furnace cement is used. When atmospheric temperature is below 5°C, these minimum curing periods shall be extended by 72hours, 36hours, and 72hours respectively.

30.4.4 DEFECTS.

The concrete shall be homogenous and free from honeycombing, interstices and planes of weakness. If, after the removal of the forms, the concrete shows any defect, the Contractor shall immediately report such defect to the Engineer, and shall not carry out any patching or remedial work until authorized to do so by the Engineer.

After thorough inspection and investigation of the quality and strength of the defective work and after due consideration of the possible consequences of such defect, the Engineer will either specify the extent and method of repair, or order the demolition and reconstruction of the whole of the defective work to the extent which he considers necessary.

The cost of all such investigation, repair and remedial work and of any demolition and reconstruction of defective work shall be borne by the Contractor and all repair, remedial and reconstruction work shall be executed to the satisfaction of the Engineer.

30.5 MASONRY WORKS

All masonry work shall comply to the specification of SECTION 4: MASONRY, and the relevant drawings.

30.5.1 BRICK WORK

All brick work shall be executed with cement bricks, as specified in SECTION 4: MASONRY. Cement bricks, of at least 11Mpa strength, 220x100x70mm, should be used for the loading ramp.

30.5.2 BRICK REINFORCING

Unless otherwise described, brick work reinforcement is to of approved SA manufactured welded high-tensile steel wire reinforcing fabric of the width stated, cut to length and lapped full width at corners and passing. Rate shall be included in the rate of brick and block work, built into walls at every second layer.

30.6 POLES

Poles shall be of the type and size indicated on the drawings. All treated timber poles shall be treated to comply with SABS 457. Timber posts shall be treated with a preservative in accordance with the requirements of SABS 05 (Creosote treated timber).

30.6.1 EUCALYPTUS OR PINEPOLES (TIMBERWORK)

30.6.1.1 DRAWINGS

DESIGN DRAWINGS:

The Engineer's drawings will include a general arrangement of the proposed structure indicating all pine or eucalyptus member sizes and special connections and will be sufficiently comprehensive to allow the detailing of all connections. Dimension figures on the drawings shall be deemed to be correct, even if the drawings are not to scale. No dimension shall be obtained from a drawing by scaling. Where necessary, the architectural drawings will also be provided.

VARIATIONS FROM DRAWINGS AND SECTIONS:

Except where otherwise authorized in writing by the Engineer, the Contractor shall ensure that the work is carried out strictly in accordance with the drawings supplied to the Contractor by the Engineer, or supplied by the Contractor and approved by the Engineer. Steel sections shall be provided as specified on the drawings except that substitution will be permitted with the Engineer's prior approval. Where the Contractor wishes to make a substitution, he shall submit his reasons and alternative proposals in writing.

30.6.1.2 FABRICATION

CUTTING:

Cutting may be done by sawing. Edges shall be free from any defects or distortions that may adversely affect the strength or serviceability of the member. All exposed burrs and similar defects shall be ground off and smoothed. The edges shall be sprayed or hand brushed with chemical after cutting in accordance with SANS 100005:2006 :8.1.1 to prevent the timber be exposed to insects or termites or fungal attack as specified by Hazard class H0-it⁰.

The engineer shall ensure that all poles are fully preserved and comply with the requirement of the relevant national standard of SANS 10005:2006, SANS538(creosoted with high temperature and be treated under moderate pressure for all resistant poles like eucalyptus) SANS 754 and SANS 753.

30.6.1.3 ASSEMBLY

GENERAL:

The component parts shall be so assembled that: -

- the whole and all parts of the finished structure are within the tolerances specified;
- no cross-pole is cut, or otherwise damaged or forced to crack at the edges;

AVOIDANCE OF EXCESSIVE STRESSES DURING CONSTRUCTION:

Drilling of vertical poles, cross-poles or composite units shall not be subjected to excessive stresses during the assembly, fabrication or erection process.

DRILLING:

Drilling shall be carried out by hand as shown on plan or in accordance to the relevant recommendations.

30.6.1.4 SETTING-OUT

Before the Contractor commences erection of work on Site, he shall check that the setting-out and the levels of concrete foundations, are in accordance with the drawings provided and he shall report any discrepancies immediately to the Engineer.

30.6.1.5 ERECTION

PROCEDURE:

Where required in terms of the project specification and before commencing erection of vertical and cross poles on Site, the Contractor shall submit to the Engineer, for his general scrutiny and information, full details of the erection procedure and methods of erection.

STORAGE AND HANDLING:

All Poles at the Site shall be so stored and handled that it is not subjected to damage the edges.

ALIGNMENT:

Creosoted poles shall be cleaned immediately before erection is commenced. All vertical poles shall be erected, aligned as soon as possible after erection to avoid abrupt setting of concrete. Vertical poles shall be erected permanently and filled with 20mpa concrete and be aligned, levelled, plumbed, and allow concrete to gain strength for 2 to 3 days before drilling.

During erection the bottom of the trench shall be filled with loose soil for 50mm and the rest of the trench of 600mm be filled with concrete.

CORRECTIONS:

A moderate degree of reaming and cutting, however, may be employed to correct minor misfits only if, in the opinion of the Engineer, this will not be detrimental to the strength or appearance of the kraal-structure. The size of holes for all vertical poles shall be exactly 650mmx400mm as shown on plan and deviation of +-50mm would be accepted.

30.6.1.6 TESTING

INSPECTION:

The Engineer shall have access at all reasonable times to all places where the work is being carried out and shall be provided with all the necessary facilities for inspection during all stages of construction.

30.6.1.7 TOLERANCE

- Spacing for vertical sections ± 20 mm from position indicated on project drawings.
- Spacing for horizontal sections ± 10 mm from position indicated on project drawings.

30.7 GATES

Gates shall be manufactured to the dimensions and details shown on the drawings.

Gates shall be complete in every respect, including hinges, washers, bolts and locking chains attached to the gate.

Gates shall be painted 2 layers with an anti-corrosion paint and 1 layer of grade 1 aluminium paint.

Gates must be made out of 40 mm, diameter x 3 mm (thickness) steel tubing.

All steel used in the manufacture of gates shall comply with requirements of SABS 1431 or SABS 657 part 1. All steel must be of grade 300 W steel.

30.7.1 PAINT

All anti-corrosion paints and other metal-coated paints and articles for the gates shall be stored in such a manner as to ensure that rainwater and condensation, which may give rise to storage staining or white rusting, drain away from the articles. The storage of anti-corrosion paint and metal paint articles shall be in accordance with the requirements of SANS ISO 12944.

30.8 BOLTS, NUTS AND WASHERS

30.8.1 BOLTS AND NUTS (other than Friction-grip)

Bolts and nuts other than fitted bolts and other than bolts and nuts for friction-grip joints shall comply with the requirements of SABS 135, SABS 136 or SABS 1143 (as applicable) for the type shown on the drawings or scheduled. Nuts shall be of at least the strength grade appropriate to the grade of bolt or other threaded element with which they are used.

The bolts and nuts which must be used on railing have to be M12 bolts of Grade 4.8 and length: 275 mm. (Threaded rod with embedded bolts and nuts will also be acceptable.)

30.9 BODY & NECK CLAMP, SCALE COMBINATION

The neck clamp must be manufactured of grade 300W steel and must be sufficiently robust for mature beef cattle handling. The steel work of the neck clamp must be painted with 2 layers of anti-corrosion

primer and 2 layers of paint to protect from corrosion. The neck clamp must be supplied as a pre-assembled unit ready for site installation.

The neck clamp mechanism must be able to operate in the following manner:

- Neck lugs to restrict movement of animal
- Immediate walk through when animal is released
- Automatic lock mechanism which prevents the opening of the yoke due to animal movement
- Manually operated opening lever.
- Full 700mm opening for large animals.
- High enough for taller animals. (2.1m)
- Variable settings of closure to prevent serious injury to animals.

Taltec neck & body clamp or similar.

NECK & BODY CLAMP



- Restrains head and body of cattle so the farmer can work with ease.
- Use for branding, dosing, inoculation, AI, embryo transplants and all general veterinary procedures.
- Clamp allows access to whole body of animal from hooves to head without injury to animal or danger to farmer, through use of removable bars and panels.
- Can be quickly adjusted to accommodate either a bull or calf.
- Brahman neck clamp in front and guillotine gate behind.
- In the event of collapse, slide out the side gate and roll out the animal.
- Clamp can be mounted on loadbars and used as a scale.
- Length 2.4m; Width 1.2m; Height 2.1m; Weight 350kg.

The scale must be manufactured of grade 300W steel and must be sufficiently robust for mature beef cattle weighing.

The scale must also be large enough by length and width for cattle weighing; at least 700mm×2400mm.

The maximum reading the scale can give must also be appropriate for mature beef cattle.

No electronics must be present. Two methods of weighing are preferred:

- A sealed, hydraulic fluid driven, load cell, or,
- A mechanical calibration beam.

The gauge dial or beam calliper must be calibrated in kg's. The accuracy of readings must be within one kg's.

The scale's gauge/beam must be able to adjust to zero, with little effort, should different crates or platforms be used by the operators.

Taltec LS4 Electronic Scale or similar. (1000mm loadbars)

LS4 ELECTRONIC SCALE



<p>ACCURACY</p> <p>± 1kg to a maximum of 2000kg ± 0.1kg to a maximum of 200kg</p>	<p>POWER SUPPLY</p> <ul style="list-style-type: none"> • 6volt internal battery-rechargeable • 12volt external source (Bakkie) • 230AC main adaptor
<p>CAPACITY</p> <p>Total capacity of scale:</p> <p>LIVE WEIGHT + PLATFORM = 2000kg</p>	<p>STATISTICS</p> <ul style="list-style-type: none"> • "Count" (number of recordings) • "Total" (group mass) • "Average" (average weight) • "Hi" (Highest mass) • "Lo" (Lowest mass)
<p>OTHER FEATURES</p> <ul style="list-style-type: none"> • Hold function • Damper (for jumping animals) • Zero or cancel any kind of platform or crate • Can be fitted to old scales 	<p>LOADBARS</p> <ul style="list-style-type: none"> • 600mm or 1000mm • Electroplated finish
<p>WARRANTY</p> <p>The scale is covered by a 12 month warranty from date of purchase.</p>	

PC 30 MEASUREMENT AND PAYMENT

30.10.1 SITE CLEARANCE

Measurement & payment will be according to the relevant section.

30.10.2 EXCAVATION

Measurement & payment will be according to the relevant section.

30.10.3 CONCRETE

Measurement & payment will be according to the relevant section.

Item **Unit**

30.10.4 CREOSOTED POLES

Work involving vertical poles will be measured by number.....No

Work involving horizontal poles will be measured by number.....No

The rate shall cover the cost of offloading the material from the vehicles on site, stacking in a designated area, moving from such area, erection, aligning, provision of erection equipment, temporary supports, safety measures, and supplying the vertical poles and cross poles for the structure, including all bolts and nuts for the erection of the kraal. The rate shall further cover the cost of access and supply and cutting of the elements, including the supply of consumables and equipment for the cleaning up of mould from bad stalked poles and protection of poles to termite's attack.

Item **Unit**

30.10.5 GATES AND STOPPER ARMS

Work involving gates and stopper arms will be measured by number.....No.

The rate shall cover the cost of offloading the material from the vehicles on site, stacking in a designated area, moving from such area, erection, aligning, provision of erection equipment, temporary supports, safety measures, and supplying the material for the gates and stopper arms. The rate shall further cover the cost of access and supply, cutting of the elements and welding for gates, including the supply of consumables and equipment for the cleaning up of mould from bad stalked poles.

Item **Unit**

30.10.6 GRAVEL AT RACE

Gravel at race.....m³

The area measured will be that of the finished surface.
The rate shall cover the cost of trimming and preparing the cleared surfaces, supplying hauling and placing all stone or gravel as specified.

Item

Unit

30.10.7 BODY & NECK CLAMP, SCALE COMBINATION

Supply and fabrication of Body & Neck Clamp, Scale Combination.....No.

The supply, transport and erecting of the Body & neck clamp, as a pre-assembled unit.
The unit rate shall cover the cost of the supply, delivery, placing and erecting of the neck clamp, scale combination.

30.10.8 MASONRY

Measurement & payment will be according to the relevant section.

30.10.9 BACKFILLING

Measurement & payment will be according to the relevant section.

31 SECTION 31: CATTLE SPRAY DIPPING FACILITY (STEEL)

31.1 SCOPE

This specification covers the supply, delivery and construction of cattle spray dip tank and stock water system, including the animal handling facility, crush with neck clamp, evaporation pond with security fence, steel storage shed and perimeter fence.

31.2 EARTH WORKS

All Earth Works for Site Clearance, General Earth Works and Earth Works for pipelines shall comply with the specifications as set out in Section 2: Earth Works and also to SANS 2001 – Construction Works Part BS1: Site clearance; SANS 2001 – Construction Works Part BE1: Earth Works (general) and SANS 2001-DP1 Construction Works. Part DP1: Earth Works for buried pipelines and prefabricated culverts.

Payment for Earth Works will be as set out in the relevant Measurement and Payment Clause for the Earth Works Section.

31.3.1 SAFETY

31.2.1 BARRICADING AND LIGHTING

In terms of the applicable regulation of the Machinery and Occupational Safety Act, 1983 (Act 6 of 1983), every excavation that is accessible to the public or that is adjacent to a public road or thoroughfare or by which the safety of persons may be endangered, shall be adequately protected by a barrier or fence of height at least 1 000 mm and as close to the excavation as practicable.

31.2.2 STORM WATER AND GROUNDWATER.

The Contractor shall properly deal with and dispose of water to ensure that the works are kept sufficiently dry for their proper execution. His responsibility will be held to include the provision of adequate protection against flooding and damage by storm water, flow from springs, and seepage, and to include provision for the repair, at his expense, of any damage to the works that may arise as a result of the inadequacy of the protection provided by him. Except where the use of tremies has been approved, foundation excavations for structures shall be kept free from water at all times until they have been inspected and approved and concrete footings have been cast.

31.2.3 EXCAVATED MATERIAL NOT TO ENDANGER OR INTERFERE.

All excavated material shall be so deposited as not to interfere with or endanger the works (for example, by causing the sides of an excavation to collapse), other property or traffic. The Engineer may order the Contractor to remove any material that the Engineer considers liable to endanger or to interfere with the works, private property, traffic or pedestrians, and to place such material at some other approved location. If the necessity for such removal is, in the opinion of the Engineer, a result of some fault on the part of the Contractor, the cost of removal shall be borne by the Contractor, but otherwise it will be borne by the Employer. All material that is unsuitable or not required for backfilling shall be removed from the site and spread, as ordered, on areas designated by the Engineer.

31.3.1 PROTECTING LIVESTOCK

From the time of the site being handed over to the Contractor up to the date of the completion certificate being issued to the contractor, he shall take all measures necessary for preventing

the ingress of vermin, and of protecting and controlling livestock, etc. on the sections of the properties affected by his operations. He shall provide gates at the positions in existing fences cut by him for gaining access and shall ensure that all gates are kept closed except when they are opened for admitting his traffic. No fences shall be cut without the approval of the engineer, and consultation with the owner of the fence.

Where alternative arrangements cannot be made, the engineer may direct the contractor to erect temporary fencing where necessary to protect livestock that may be lost or are exposed to vermin through his operations. Such fencing shall be of an adequate standard and shall be erected ahead of construction operations. The fencing shall be maintained in a good order during construction operations and, on completion of the work, it shall be removed from the site and all surfaces shall be restored. The engineer may order that any permanent fencing which is required erected up ahead of construction operations, where practicable, in lieu of erecting temporary fencing.

Payment for the protection of livestock, excluding the erection of temporary fences, shall be included in the amounts tendered for the contractor's establishment on the site.

31.3 CONCRETE WORKS

All Concrete, Formwork and Reinforcement shall comply to the specifications of Section 3: CONCRETE, FORMWORK AND REINFORCEMENT

Structural Works

Applicable standard: SANS 2001 – Construction Works Part CC1: Concrete Works (structural).

Minor Works

Applicable standard: SANS 2001 – Construction Works Part CC2: Concrete Works (minor works).

Foundations

Applicable standard: SANS 2001 – Construction Works Part CM2: Strip footings, Pad footings and Slab-on-the-ground Foundations for Masonry Walling

Payment for Concrete will be as set out in the relevant Measurement and Payment Clause for this section.

31.3.1 COMPACTION.

The concrete shall be fully compacted by approved means during and immediately after placing. It shall be thoroughly worked against the formwork and around reinforcement and other embedded items without displacing them.

The concrete shall be free from honeycombing and planes of weakness. Successive layers of the same lift shall be thoroughly worked together. To achieve this, the compaction tool shall penetrate through the new layer to the lower layer which shall still be sufficiently plastic to permit interknitting.

Compaction shall be carried out by mechanical vibration or (if approved) by spading, prodding, or forking. Over vibration resulting in segregation, surface laitance, or leakage, or any combination of these, shall not be permitted.

31.3.1 CURING AND PROTECTION.

After formwork has been removed and as soon as it is practicable in the opinion of the Engineer, all concrete shall be protected from contamination and loss of moisture by one or more of the following methods:

- d) Ponding the exposed surfaces by means of water except under cold weather conditions (concrete surfaces shall not be wet intermittently by spraying or otherwise).
- e) Covering the concrete with sand or mats made of moisture retaining material, and keeping the covering continuously wet
- f) The use of an approved curing compound applied in accordance with the manufacturer's instructions. The curing period shall be at least 5days for the concrete made with Portland cement, at least 2days for concrete made with rapid – hardening Portland cement, and at least 7days if Portland blast furnace cement is used. When atmospheric temperature is below 5°C, these minimum curing periods shall be extended by 72hours, 36hours, and 72hours respectively.

31.3.1 CONCRETE SURFACES.

Exposed surfaces of concrete not finished against forms (such as horizontal or slightly sloping surfaces) shall be brought up to a plane, uniform surface with suitable screed boards.

Where a wood float or steel float finish or a screed topping or a granolithic finish is required in terms of the project specification, the concrete shall, unless otherwise stated in the project specification, be finished to the applicable tolerances specified.

Finished concrete shall have a neat, smooth, even and uniform finish free from any honeycombing. If the finish of any formed or floated concrete surface is unsatisfactory and does not conform to that specified, the Contractor will be required, at his own expense, to rub down such surface while it is still green, or, alternatively, to grind it down with carborundum or other suitable material when it has hardened, or to take other approved remedial measures to give the specified finish.

31.3.1 WATER TIGHT CONCRETE.

The spray dip reservoir and main race floor shall be water tight. Special care shall be taken by the Contractor to ensure water tightness, particularly at the construction joints. Should any such section of the spray dip reservoir and main race floor, show any sign of water leakage or penetration after being taken into use, it shall be deemed defective.

31.3.1 DEFECTS.

The concrete shall be homogenous and free from honeycombing, interstices and planes of weakness. If, after the removal of the forms, the concrete shows any defect, the Contractor shall immediately report such defect to the Engineer, and shall not carry out any patching or remedial work until authorized to do so by the Engineer.

After thorough inspection and investigation of the quality and strength of the defective work and after due consideration of the possible consequences of such defect, the Engineer will either specify the extent and method of repair, or order the demolition and reconstruction of the whole of the defective work to the extent which he considers necessary.

The cost of all such investigation, repair and remedial work and of any demolition and reconstruction of defective work shall be borne by the Contractor and all repair, remedial and reconstruction work shall be executed to the satisfaction of the Engineer.

31.3.1 GROUTED STONE PITCHING

The holding pen area and the race must be cleaned to a slope indicated on the plan. After the clearance of all the organic material, rocks of a high 100 mm – 150 mm must be place for the whole floor of the holding pen area and the exit of the race after the neck clamp. After the rocks are placed you compile a mortar mixture of 1:150 and placed it on top and in between the rocks that is placed. The mortar mixture must be smoothed on top of the placed rock.

31.4 HANDLING FACILITY (STEEL COMPONENTS)

31.3.1 GENERAL

All steelwork shall comply with the requirements of the specifications as set out in Section 6: STRUCTURAL STEELWORK as well as that of SANS 2001- Part CS1: Specification for Construction Works – Structural steelwork.

ASSEMBLY

The component parts shall be so assembled that: -

- the whole and all parts of the finished structure are within the tolerances specified;
- no horizontal member is cut, or otherwise damaged or forced.

AVOIDANCE OF EXCESSIVE STRESSES DURING CONSTRUCTION

IPE posts or Horizontal members or composite units shall not be subjected to excessive stresses during the assembly, fabrication or erection process.

TOLERANCE

- Spacing for vertical sections ± 20 mm from position indicated on project drawings.
- Spacing for horizontal sections ± 10 mm from position indicated on project drawings

All steelwork with the exception of steel reinforcement for the concrete works must be of grade 300W steel.

All steel shall be painted with 2 layers of SABS 312 Red Lead Base Primers for Structural Steel and 1 layer of SABS approved grade 1 Silver Shine Aluminum paint.

31.3.1 STEEL FOR HANDLING FACILITY

Vertical Posts for race shall be IPE_{aa} 100 x 55 x 2400mm sections with base plates of 150 x 150 x 4mm.

Horizontal members for the cruch and main race shall be Cold Formed Lip Channel sections of 70 x 50 x 20mm.

31.3.1 HEAVY DUTY AUCTION GATES

Auction Gates shall be heavy duty auction type gates manufactured and installed to the dimensions and details shown on the drawings for stock handling purposes and at positions as indicated.

The frame shall be of tubing of bore 42mm and wall thickness of 3,0mm in the case of main frame members, and inside bracing members of gate shall be flat bar of 25mm and thicknes of 5mm.

Auction Gates shall be complete in every respect, including hinges, washers, bolts and locking chains attached to the gate.

Gates shall be painted with 2 layers of SABS 312 Red Lead Base Primers for Structural Steel and 1 layer of SABS approved grade 1 Silver Shine Aluminum paint.

31.3.1 NECK CLAMP

The neck clamp must be manufactured of grade 300W steel and must be sufficiently robust for mature beef cattle handling, "Taltec or Similar".

The steel work of the neck clamp must be painted 2 layers of SABS 312 Red Lead Base Primers for Structural Steel and 1 layer of SABS approved grade 1 Silver Shine Aluminum paint.

The neck clamp must be supplied as a pre-assembled unit ready for site installation.



The neck clamp mechanism must be able to operate in the following manner:

- Neck lugs to restrict movement of animal
- Immediate walk through when animal is released
- Automatic lock mechanism which prevents the opening of the yoke due to animal movement
- Manually operated opening lever.
- Full 700mm opening for large animals.
- Variable settings of closure to prevent serious injury to animals.

31.3.1 SPRAY DIP

The spray dip must be manufactured of grade 300W steel and must be sufficiently robust for mature beef cattle handling, "Taltec or Similar".

The steel work of the spray dip must be painted 2 layers of SABS 312 Red Lead Base Primers for Structural Steel and 1 layer of SABS approved grade 1 Silver Shine Aluminum paint.

The spray dip must be supplied as a pre-assembled unit ready for site installation complete with Arch frames, Petrol pump (Honda WL30XH or similar) 3" with 80mm quick coupling fittings for hoses, 1300 litre water tank, chute with return flow screen (sieve), 36 nozzles (jets), 1 x 80mm suction pipe with foot valve, 1 x 80mm delivery pipe and IBR sheets/cladding for spray dip.



31.5 MATERIALS AND DIMENTIONS FOR SPRAY RESERVIOR TANK AND PUMP TERRAIN

The fence will cover an area of 3 x 6m where the spray reservoir and pump will be installed.

31.1.1 CORNER- AND GATE POSTS AND BRACES:

Corner-, Straining-, Anchor-, Gate Posts and Braces shall be as per SECTION 19: STOCK FENCES.

31.1.2 STANDARDS:

Standards shall be shall be as per SECTION 19: STOCK FENCES.

31.1.3 WIRE:

Wire shall be as per specifications in SECTION 19: STOCK FENCES. (2,00mm diameter lightly galvanised zinc-coated mild steel barbed wire double-strand uni-directional twist wire, each strand 2mm in diameter, for use at any height above ground. Barbs shall be manufactured from 1,8mm - 2,0mm lightly galvanized zinc-coated mild steel wire and shall be spaced at not more than 150 mm)

31.1.4 GALVANIZED WIRE WELDED MESH:

Wire netting shall be Galvanized Wire Welded Mesh. (Lightly galvanized mild-steel wire with a minimum diameter of 1,8 mm, and the mesh size shall be 100 mm x 50 mm x 1200 mm)

Four strands of barbed wire shall be stringed at equal spacing between the top and bottom of the corner posts, to support the welded mesh. All fencing wire shall be tied to the sides of standards and posts to prevent the wires from being displaced or becoming loose.

Wire welded mesh shall be stretched against the fence and properly tied to the fencing wire. The weld mesh shall be secured by soft tying wire at 1,2 m distances along the top, centre and bottom wires and at all standards and corner posts.

31.1.5 GATES:

Gates shall be manufactured to the dimensions and details as per specifications in SECTION 19: STOCK FENCES. Gates shall be manufactured of mild steel tubing having continuously welded seams.

The gate shall be a pedestrian gate 1200mm x 1200mm as shown on the drawings.

Gates shall be complete in every respect, including hinges, washers, bolts and locking chains attached to the gate.

Gates shall be painted with 2 x coats high quality Rust Preventative Paint and finish off with 2 x coats Silver Shine Aluminum paint.

31.6 STEEL STORAGE SHED

The Steel Storage Shed shall be installed as per drawing or as indicated by the engineer.

All materials, construction and works done shall comply with the specifications as set out in Section 34: STEEL SHED.

Payment for Stock Water System will be as set out in the relevant Measurement and Payment Clause for the Steel Shed Section.

31.7 STOCK WATER SYSTEM

The stock water system shall be installed as per drawing or as indicated by the engineer.

All materials, construction and works done shall comply with the specifications as set out in Section 21: STOCK WATER SYSTEM.

Payment for Stock Water System will be as set out in the relevant Measurement and Payment Clause for the Stock Water System Section.

31.8 PERIMETER STOCK FENCE AROUND DIP TANK AND FACILITIES

The perimeter stock fence shall be installed as per drawing or as indicated by the engineer.

All materials, construction and work done shall comply to the specifications of Section 19: STOCK FENCING

Payment for Perimeter Stock Fence will be as set out in the relevant Measurement and Payment Clause for the Stock Fence Section.

PC 31 MEASUREMENT AND PAYMENT

Item	Unit
PC 31.1 Vertical IPE posts for crush (IPE _{aa} 100 x 55 x 2400mm sections with base plates of 150 x 150 x 4mm)	Number (No)

The unit of measurement for erecting Vertical IPE Posts shall be the number of posts erected.

The tendered rate shall be in full compensation for supply, delivery of all materials and components required to construct the posts, all labour, tools and plant for the complete erection thereof as specified.

Item	Unit
PC 31.2 Horizontal Lip Channel (CFL Channel of 70 x 50 x 20mm X 6m length)	Number (No)

The unit of measurement for erecting horizontal lip channel members shall be the number of members erected.

The tendered rate shall be in full compensation for supply, delivery of all materials and components required to construct the lip channel members, all labour, tools and plant for the complete erection thereof as specified.

Item	Unit
PC 31.3 Neck Clamp.	(no)

The unit of measurement for the neck clamp shall be in number (No) of the components as specified in the Bill of Quantities.

The tendered rate shall be in full compensation for supply, delivery of neck clamp and labour to assemble and fit. Including all welding materials, cutting materials and fastening materials.

Item	Unit
PC 31.4 Spray Dip.	Number (no)

The unit of measurement for the spray dip shall be in number (No) of the components as specified in the Bill of Quantities.

The tendered rate shall be in full compensation for supply, delivery of neck clamp and labour to assemble and fit. Including all welding materials, cutting materials and fastening materials.

Item	Unit
PC 31.5 Grouted Stone Pitching	square metre (m ²)

The unit of measurement for the laying of the grouted stone pitching shall be the square metre area of stone pitching.

The tendered rate shall be in full compensation for supply, delivery of all materials, labour and plant for the complete laying of the stone pitching as per the specifications.

Item	Unit
PC 31.6 Extra Over for Transport on import of stone	(R/km)

Extra over for transport of stone for stone pitching beyond 50km. The rate will be rand/km.

Item	Unit
PC 31.7 Water supply to dip tank	Sum

The unit of measurement for the supply of water to the dip tank shall be the Sum.

The tendered rates shall be in full compensation for the supply, delivery and installation of the water supply system.

32 SECTION 32: CATTLE SPRAY DIPPING FACILITY (TIMBER)

32.1 SCOPE

This specification covers the supply, delivery and construction of cattle plunge dip tank, including the animal handling facility, crush with neck clamp, evaporation pond with security fence and perimeter fence.

32.2 EARTH WORKS

All Earth Works for Site Clearance, General Earth Works and Earth Works for pipelines shall comply with the specifications as set out in Section 2: Earth Works and also to SANS 2001 – Construction Works Part BS1: Site clearance; SANS 2001 – Construction Works Part BE1: Earth Works (general) and SANS 2001-DP1 Construction Works. Part DP1: Earth Works for buried pipelines and prefabricated culverts.

Payment for Earth Works will be as set out in the relevant Measurement and Payment Clause for this section.

32.2.1 SAFETY

32.2.1.1 BARRICADING AND LIGHTING

In terms of the applicable regulation of the Machinery and Occupational Safety Act, 1983 (Act 6 of 1983), every excavation that is accessible to the public or that is adjacent to a public road or thoroughfare or by which the safety of persons may be endangered, shall be adequately protected by a barrier or fence of height at least 1 000 mm and as close to the excavation as practicable.

32.2.2 Storm Water and Groundwater.

The Contractor shall properly deal with and dispose of water to ensure that the works are kept sufficiently dry for their proper execution. His responsibility will be held to include the provision of adequate protection against flooding and damage by storm water, flow from springs, and seepage, and to include provision for the repair, at his expense, of any damage to the works that may arise as a result of the inadequacy of the protection provided by him. Except where the use of tremies has been approved, foundation excavations for structures shall be kept free from water at all times until they have been inspected and approved and concrete footings have been cast.

32.2.3 Excavated Material Not to Endanger or Interfere.

All excavated material shall be so deposited as not to interfere with or endanger the works (for example, by causing the sides of an excavation to collapse), other property or traffic. The Engineer may order the Contractor to remove any material that the Engineer considers liable to endanger or to interfere with the works, private property, traffic or pedestrians, and to place such material at some other approved location. If the necessity for such removal is, in the opinion of the Engineer, a result of some fault on the part of the Contractor, the cost of removal shall be borne by the Contractor, but otherwise it will be borne by the Employer. All material that is unsuitable or not required for backfilling shall be removed from the site and spread, as ordered, on areas designated by the Engineer.

32.2.4 PROTECTING LIVESTOCK

From the time of the site being handed over to the Contractor up to the date of the completion certificate being issued to the contractor, he shall take all measures necessary for preventing

the ingress of vermin, and of protecting and controlling livestock, etc. on the sections of the properties affected by his operations. He shall provide gates at the positions in existing fences cut by him for gaining access and shall ensure that all gates are kept closed except when they are opened for admitting his traffic. No fences shall be cut without the approval of the engineer, and consultation with the owner of the fence.

Where alternative arrangements cannot be made, the engineer may direct the contractor to erect temporary fencing where necessary to protect livestock that may be lost or are exposed to vermin through his operations. Such fencing shall be of an adequate standard and shall be erected ahead of construction operations. The fencing shall be maintained in a good order during construction operations and, on completion of the work, it shall be removed from the site and all surfaces shall be restored. The engineer may order that any permanent fencing which is required erected up ahead of construction operations, where practicable, in lieu of erecting temporary fencing.

Payment for the protection of livestock, excluding the erection of temporary fences, shall be included in the amounts tendered for the contractor's establishment on the site.

32.3 **CONCRETE WORKS**

All Concrete, Formwork and Reinforcement shall comply to the specifications of Section 3: CONCRETE, FORMWORK AND REINFORCEMENT

Structural Works

Applicable standard: SANS 2001 – Construction Works Part CC1: Concrete Works (structural).

Minor Works

Applicable standard: SANS 2001 – Construction Works Part CC2: Concrete Works (minor works).

Foundations

Applicable standard: SANS 2001 – Construction Works Part CM2: Strip footings, Pad footings and Slab-on-the-ground Foundations for Masonry Walling

Payment for Concrete will be as set out in the relevant Measurement and Payment Clause for this section.

32.3.1 **COMPACTION.**

The concrete shall be fully compacted by approved means during and immediately after placing. It shall be thoroughly worked against the formwork and around reinforcement and other embedded items without displacing them.

The concrete shall be free from honeycombing and planes of weakness. Successive layers of the same lift shall be thoroughly worked together. To achieve this, the compaction tool shall penetrate through the new layer to the lower layer which shall still be sufficiently plastic to permit interknitting.

Compaction shall be carried out by mechanical vibration or (if approved) by spading, prodding, or forking. Over vibration resulting in segregation, surface laitance, or leakage, or any combination of these, shall not be permitted.

32.3.2 CURING AND PROTECTION.

After formwork has been removed and as soon as it is practicable in the opinion of the Engineer, all concrete shall be protected from contamination and loss of moisture by one or more of the following methods:

- a) Ponding the exposed surfaces by means of water except under cold weather conditions (concrete surfaces shall not be wet intermittently by spraying or otherwise).
- b) Covering the concrete with sand or mats made of moisture retaining material, and keeping the covering continuously wet
- c) The use of an approved curing compound applied in accordance with the manufacturer's instructions. The curing period shall be at least 5days for the concrete made with Portland cement, at least 2days for concrete made with rapid – hardening Portland cement, and at least 7days if Portland blast furnace cement is used. When atmospheric temperature is below 5°C, these minimum curing periods shall be extended by 72hours, 36hours, and 72hours respectively.

32.3.3 CONCRETE SURFACES.

Exposed surfaces of concrete not finished against forms (such as horizontal or slightly sloping surfaces) shall be brought up to a plane, uniform surface with suitable screed boards.

Where a wood float or steel float finish or a screed topping or a granolithic finish is required in terms of the project specification, the concrete shall, unless otherwise stated in the project specification, be finished to the applicable tolerances specified.

Finished concrete shall have a neat, smooth, even and uniform finish free from any honeycombing. If the finish of any formed or floated concrete surface is unsatisfactory and does not conform to that specified, the Contractor will be required, at his own expense, to rub down such surface while it is still green, or, alternatively, to grind it down with carborundum or other suitable material when it has hardened, or to take other approved remedial measures to give the specified finish.

32.3.4 WATER TIGHT CONCRETE.

The spray dip reservoir and main race floor shall be water tight. Special care shall be taken by the Contractor to ensure water tightness, particularly at the construction joints. Should any such section of the spray dip reservoir and main race floor, show any sign of water leakage or penetration after being taken into use, it shall be deemed defective.

32.3.5 DEFECTS.

The concrete shall be homogenous and free from honeycombing, interstices and planes of weakness. If, after the removal of the forms, the concrete shows any defect, the Contractor shall immediately report such defect to the Engineer, and shall not carry out any patching or remedial work until authorized to do so by the Engineer.

After thorough inspection and investigation of the quality and strength of the defective work and after due consideration of the possible consequences of such defect, the Engineer will either specify the extent and method of repair, or order the demolition and reconstruction of the whole of the defective work to the extent which he considers necessary.

The cost of all such investigation, repair and remedial work and of any demolition and reconstruction of defective work shall be borne by the Contractor and all repair, remedial and reconstruction work shall be executed to the satisfaction of the Engineer.

32.3.6 GROUTED STONE PITCHING

The holding pen area and the race must be cleaned to a slope indicated on the plan. After the clearance of all the organic material, rocks of a high 100 mm – 150 mm must be placed for the whole floor of the holding pen area and the exit of the race after the neck clamp. After the rocks are placed you compile a mortar mixture of 1:150 and placed it on top and in between the rocks that is placed. The mortar mixture must be smoothed on top of the placed rock.

32.4 HANDLING FACILITY (TIMBER COMPONENTS)

32.4.1 POSTS AND RAILS

Posts and Rails shall be Eucalyptus or Pinepoles wooden poles and of quality suitable for fencing and to the size indicated on the drawings.

All treated timber poles shall be treated to comply with SABS 457. Timber posts shall be treated with a preservative in accordance with the requirements of SABS 1288 (Preservative treated timber) or SABS 05 (Creosote treated timber).

Posts and Rails shall be treated and bearing the SANS mark.

Vertical Posts shall be 125/150mm diameter x 2.4m length.

Horizontal Members/Rails shall be 100/125mm diameter x 3m length.

At the bottom of each post, 150mm from the bottom of the post, a 10mm hole will be drilled through the post. Thereafter a 10mm reinforcing bar of 250mm will be fitted in the hole before planting the post.

32.4.2 FABRICATION

CUTTING

Cutting may be done by sawing. Edges shall be free from any defects or distortions that may adversely affect the strength or serviceability of the member. All exposed burrs and similar defects shall be ground off and smoothed. The edges shall be sprayed or hand brushed with chemical after cutting in accordance with SANS 100005:2006: 8.1.1 to prevent the timber be exposed to insects or termites or fungal attack as specified by Hazard class H0-it⁰.

The Contractor shall ensure that all poles are fully preserved and comply with the requirement of the relevant national standard of SANS 10005:2006, SANS538 (creosoted with high temperature and be treated under moderate pressure for all resistant poles like eucalyptus) SANS 754 and SANS 753.

ASSEMBLY

GENERAL

The component parts shall be so assembled that: -

- the whole and all parts of the finished structure are within the tolerances specified;
- no cross-pole is cut, or otherwise damaged or forced to crack at the edges;

AVOIDANCE OF EXCESSIVE STRESSES DURING CONSTRUCTION

Drilling of vertical poles, cross-poles or composite units shall not be subjected to excessive stresses during the assembly, fabrication or erection process.

DRILLING

Drilling shall be carried out by hand as shown on plan or in accordance to the relevant recommendations.

TOLERANCE

- Spacing for vertical sections ± 20 mm from position indicated on project drawings.
- Spacing for horizontal sections ± 10 mm from position indicated on project drawings.

32.4.3 SORTING GATE

The Sorting Gate shall be a special manufactured structure delivered to site ready for installation.

Gates shall be painted with 2 layers of SABS approved an anti-corrosion paint and 2 layers of SABS approved grade 1 aluminium paint.

32.4.4 AUCTION GATES

Auction Gates shall be heavy duty auction type gates manufactured and installed to the dimensions and details shown on the drawings for stock handling purposes and at positions as indicated.

The frame shall be of tubing of bore 42mm and wall thickness of 3,0mm in the case of main frame members, and inside bracing members of gate shall be flat bar of 25mm and thicknes of 5mm.

Auction Gates shall be complete in every respect, including hinges, washers, bolts and locking chains attached to the gate.

Gates shall be painted with 2 layers of SABS 312 Red Lead Base Primers for Structural Steel and 1 layer of SABS approved grade 1 Silver Shine Aluminum paint.

32.4.5 NECK CLAMP

The neck clamp must be manufactured of grade 300W steel and must be sufficiently robust for mature beef cattle handling, "Taltec or Similar".

The steel work of the neck clamp must be painted 2 layers of SABS 312 Red Lead Base Primers for Structural Steel and 1 layer of SABS approved grade 1 Silver Shine Aluminum paint.

The neck clamp must be supplied as a pre-assembled unit ready for site installation.



The neck clamp mechanism must be able to operate in the following manner:

- Neck lugs to restrict movement of animal
- Immediate walk through when animal is released
- Automatic lock mechanism which prevents the opening of the yoke due to animal movement
- Manually operated opening lever.
- Full 700mm opening for large animals.
- Variable settings of closure to prevent serious injury to animals.

32.4.6 SPRAY DIP

The spray dip must be manufactured of grade 300W steel and must be sufficiently robust for mature beef cattle handling, "Taltec or Similar".

The steel work of the spray dip must be painted 2 layers of SABS 312 Red Lead Base Primers for Structural Steel and 1 layer of SABS approved grade 1 Silver Shine Aluminum paint

The spray dip must be supplied as a pre-assembled unit ready for site installation complete with Arch frames, Petrol pump (Honda WL30XH or similar) 3" with 80mm quick coupling fittings for hoses, 1300 litre water tank, chute with return flow screen (sieve), 36 nozzles (jets), 1 x 80mm suction pipe with foot valve, 1 x 80mm delivery pipe and IBR sheets/cladding for spray dip.



32.5 MATERIALS AND DIMENTIONS FOR SPRAY RESERVIOIR TANK AND PUMP TERRAIN

The fence will cover an area of 3 x 6m where the spray reservoir and pump will be installed.

32.5.1 CORNER- AND GATE POSTS AND BRACES:

Corner-, Straining-, Anchor-, Gate Posts and Braces shall be as per SECTION 19: STOCK FENCES.

32.5.2 STANDARDS:

Standards shall be shall be as per SECTION 19: STOCK FENCES.

32.5.3 WIRE:

Wire shall be as per specifications in SECTION 19: STOCK FENCES. (2,00mm diameter lightly galvanised zinc-coated mild steel barbed wire double-strand uni-directional twist wire, each strand 2mm in diameter, for use at any height above ground. Barbs shall be

manufactured from 1,8mm - 2,0mm lightly galvanized zinc-coated mild steel wire and shall be spaced at not more than 150 mm)

32.5.4 GALVANIZED WIRE WELDED MESH:

Wire netting shall be Galvanized Wire Welded Mesh. (Lightly galvanized mild-steel wire with a minimum diameter of 1,8 mm, and the mesh size shall be 100 mm x 50 mm x 1200 mm)

Four strands of barbed wire shall be stringed at equal spacing between the top and bottom of the corner posts, to support the welded mesh. All fencing wire shall be tied to the sides of standards and posts to prevent the wires from being displaced or becoming loose.

Wire welded mesh shall be stretched against the fence and properly tied to the fencing wire. The weld mesh shall be secured by soft tying wire at 1,2 m distances along the top, centre and bottom wires and at all standards and corner posts.

32.5.5 GATES:

Gates shall be manufactured to the dimensions and details as per specifications in SECTION 19: STOCK FENCES. Gates shall be manufactured of mild steel tubing having continuously welded seams.

The gate shall be a pedestrian gate 1200mm x 1200mm as shown on the drawings.

Gates shall be complete in every respect, including hinges, washers, bolts and locking chains attached to the gate.

Gates shall be painted with 2 x coats high quality Rust Preventative Paint and finish off with 2 x coats Silver Shine Aluminum paint.

32.6 STEEL STORAGE SHED

The Steel Storage Shed shall be installed as per drawing or as indicated by the engineer.

All materials, construction and works done shall comply with the specifications as set out in Section 34: STEEL SHED.

Payment for Stock Water System will be as set out in the relevant Measurement and Payment Clause for the Steel Shed Section

32.7 STOCK WATER SYSTEM

The stock water system shall be installed as per drawing or as indicated by the engineer.

All materials, construction and works done shall comply with the specifications as set out in Section 21: STOCK WATER SYSTEM.

Payment for Stock Water System will be as set out in the relevant Measurement and Payment Clause for the Stock Water System Section.

32.8 PERIMETER STOCK FENCE AROUND DIP TANK AND FACILITIES

The perimeter stock fence shall be installed as per drawing or as indicated by the engineer.

All materials, construction and work done shall comply to the specifications of Section 19: STOCK FENCING

Payment for Perimeter Stock Fence will be as set out in the relevant Measurement and Payment Clause for the Stock Fence Section.

PC 32 MEASUREMENT AND PAYMENT

Item	Unit
PC 32.1 Vertical Posts (125/150 x 2.4m Length)	Number (No)

The unit of measurement for erecting Vertical Timber Posts shall be the number of posts erected.

The tendered rate shall be in full compensation for supply, delivery of all materials and components required to construct the posts, all labour, tools and plant for the complete erection thereof as specified.

Item	Unit
PC 32.2 Horizontal Members/Rails (100/125 x 3m length)	Number (No)

The unit of measurement for erecting Horizontal Timber Members/Rails shall be the number of members/rails erected.

The tendered rate shall be in full compensation for supply, delivery of all materials and components required to construct the posts, all labour, tools and plant for the complete erection thereof as specified.

Item	Unit
PC 32.3 10 mm Rebars (350mm long)	Number (No)

The unit of measurement for fixing the 10 mm rebars through the bottom of vertical poles shall be the number of rebars.

The tendered rate shall be in full compensation for supply, delivery of all materials and components required to site, all labour, tools and plant for the cutting, drilling of holes and fixing of rebars to ensure the complete erection thereof as specified.

Item	Unit
PC 32.4 M12 threaded bar with flat washers and hexagonal nuts	Number (No)

The unit of measurement for fixing the M 12 threaded bar with washers and lock nuts shall be the number as per bill.

The tendered rate shall be in full compensation for supply, delivery of all materials and components required to site, all labour, tools and plant for the cutting, drilling of holes and fixing of M 12 threaded bar with washers and lock nuts to ensure the complete erection thereof as specified.

Item	Unit
PC 32.5 Neck Clamp	Number (no)

The unit of measurement for the neck clamp shall be in number (No) of the components as specified in the Bill of Quantities.

The tendered rate shall be in full compensation for supply, delivery of neck clamp and labour to assemble and fit. Including all welding materials, cutting materials and fastening materials.

Item	Unit
PC 32.6 Spray Dip	Number (no)

The unit of measurement for the spray dip shall be in number (No) of the components as specified in the Bill of Quantities.

The tendered rate shall be in full compensation for supply, delivery of neck clamp and labour to assemble and fit. Including all welding materials, cutting materials and fastening materials.

Item	Unit
PC 32.7 Grouted Stone Pitching	square metre (m ²)

The unit of measurement for the laying of the grouted stone pitching shall be the square metre area of stone pitching.

The tendered rate shall be in full compensation for supply, delivery of all materials, labour and plant for the complete laying of the stone pitching as per the specifications.

Item	Unit
PC 32.8 Extra Over for Transport on import of stone	(R/km)

Extra over for transport of stone for stone pitching beyond 50km. The rate will be rand/km.

Item	Unit
PC 32.9 Auction Gate (3.0m x 1.5m high)	Number (No)

The unit of measurement for the gate complete shall be the number (No) of gates erected as per the specifications and drawings.

The tendered rates shall be in full compensation for the supply, delivery of all materials and components required to the site all labour, tools and plant to install the gates as indicated on the drawings.

Item	Unit
PC 32.10 Water supply to dip tank	Sum

The unit of measurement for the supply of water supply system to the dip tank shall be the Sum.

The tendered rates shall be in full compensation for the supply, delivery and installation of the water supply system.

33 SECTION 33: STANDARD MULTI-PURPOSE SHED

33.1 SCOPE

This section covers the design, drawings, design certificate, supply of all material and the construction of a steel portal frame multipurpose shed for agricultural purposes as indicated on the drawings or as directed by the Engineer.

The contract period is four months, during which CPA is applicable.

33.2 SUPPORTING SPECIFICATIONS

The specification shall be read in conjunction with the following latest issues of standards as published by the South African Bureau of Standards:

SANS 1200 H: Structural Steelwork (1990)
SANS 1200 HB: Cladding and Sheeting (1985)
SANS 1200 HC: Corrosion Protection of Structural Steelwork (1988)
SANS 1200 LE: Storm-water Drainage (1982)
SANS 684: Structural Steel Paint
SANS 135: ISO Metric Black Bolts, Screws & Nuts
CKS 264: Flat Mild Steel Washers

33.3 MATERIALS

33.3.1 APPROVAL OF MATERIALS:

The supplier/contractor shall provide the DRDAR with a certificate from an accredited Testing Service Provider that the material supplied complies with the required SANS codes as prescribed.

The Contractor / Tenderer shall supply in good time to the Employer's Agent, for his approval, samples of the following:

- materials for use in the concrete,
- materials to be used for steel structure,
- materials for use in cladding & sheeting,
- materials for use in corrosion protection.

33.3.2 LOCAL CONTENT:

This bid documents carries a minimum threshold for local content of 100% for all items that are manufactured with:

1. Fabricated structural steel
2. Structural Steel Pipe
3. Steel Fasteners
4. Steel Frames
5. Roofing and Cladding

33.4 EARTH WORKS

All Earth Works for Site Clearance, General Earth Works and Earth Works for pipelines shall comply with the specifications as set out in SECTION 2: EARTH WORKS, and also to SANS 2001 – Construction Works Part BS1: Site clearance; SANS 2001 – Construction Works Part BE1: Earth Works (general) and SANS 2001-DP1 Construction Works. Part DP1: Earth Works for buried pipelines and prefabricated culverts.

Payment for Earth Works will be as set out in the relevant Measurement and Payment Clause for this section.

33.4.1 SAFETY:

33.4.1.1 Barricading and Lighting

In terms of the applicable regulation of the Machinery and Occupational Safety Act, 1983 (Act 6 of 1983), every excavation that is accessible to the public or that is adjacent to a public road or thoroughfare or by which the safety of persons may be endangered, shall be adequately protected by a barrier or fence of height at least 1 000 mm and as close to the excavation as practicable.

33.4.1.2 Storm Water and Groundwater.

The Contractor shall properly deal with and dispose of water to ensure that the works are kept sufficiently dry for their proper execution. His responsibility will be held to include the provision of adequate protection against flooding and damage by storm water, flow from springs, and seepage, and to include provision for the repair, at his expense, of any damage to the works that may arise as a result of the inadequacy of the protection provided by him. Except where the use of tremies has been approved, foundation excavations for structures shall be kept free from water at all times until they have been inspected and approved and concrete footings have been cast.

33.4.1.3 Excavated Material Not to Endanger or Interfere.

All excavated material shall be so deposited as not to interfere with or endanger the works (for example, by causing the sides of an excavation to collapse), other property or traffic. The Engineer may order the Contractor to remove any material that the Engineer considers liable to endanger or to interfere with the works, private property, traffic or pedestrians, and to place such material at some other approved location. If the necessity for such removal is, in the opinion of the Engineer, a result of some fault on the part of the Contractor, the cost of removal shall be borne by the Contractor, but otherwise it will be borne by the Employer. All material that is unsuitable or not required for backfilling shall be removed from the site and spread, as ordered, on areas designated by the Engineer.

33.4.1.4 PROTECTING LIVESTOCK

From the time of the site being handed over to the Contractor up to the date of the completion certificate being issued to the contractor, he shall take all measures necessary for preventing the ingress of vermin, and of protecting and controlling livestock, etc. on the sections of the properties affected by his operations. He shall provide gates at the positions in existing fences cut by him for gaining access and shall ensure that all gates are kept closed except when they are opened for admitting his traffic. No fences shall be cut without the approval of the engineer, and consultation with the owner of the fence.

Where alternative arrangements cannot be made, the engineer may direct the contractor to erect temporary fencing where necessary to protect livestock that may be lost or are exposed to vermin through his operations. Such fencing shall be of an adequate standard and shall be erected ahead of construction operations. The fencing shall be maintained in a good order during construction operations and, on completion of the work, it shall be removed from the site and all surfaces shall be restored. The engineer may order that any permanent fencing which is required erected up ahead of construction operations, where practicable, in lieu of erecting temporary fencing.

Payment for the protection of livestock, excluding the erection of temporary fences, shall be included in the amounts tendered for the contractor's establishment on the site.

33.4.2 COMPACTED FILLING MATERIAL SUPPLIED BY THE CONTRACTOR

33.4.2.1 COMPACTION MATERIAL UNDER FLOOR

Filling under solid floor will be executed with imported G5 material dry earth, free from clay and spread evenly in layers not more than 200mm thick, well compacted.

The subgrade shall be compacted to 95% MOD ASSHTO density. A minimum of six positions shall be pointed out by the Engineer for density testing. The first passed test shall be paid in accordance to the bill of quantities. Should the test fail, the contractor shall be liable for the re-compaction and the subsequent tests of the re-compacted materials until it meet the required compaction strength.

When in the opinion of the Engineer, the density of the under surface material is not suitable, the surface shall be scarified to a depth of 150mm with a mechanical ripper or other approved equipment, watered and re-compacted to 90% MOD ASSHTO density.

33.4.1.5 GRAVEL DRESSING OF CONSOLIDATED 75MM THICKNESS

Gravel cover on terrain will be executed with imported G5 material dry earth, free from clay and spread evenly in layers, well compacted to a minimum thickness of 75mm.

Measurement and payment will be according to the relevant section.

33.5 CONCRETE WORKS

All Concrete, Formwork and Reinforcement shall comply to the specifications of SECTION 3: CONCRETE, FORMWORK AND REINFORCEMENT, and the relevant drawings and bill of quantities.

33.5.1 FORMWORK:

All formwork will be executed according to the relevant specifications of SECTION 3. Formwork shall be approved by the Engineer, prior to any pouring of concrete will be allowed.

33.5.2 REINFORCEMENT:

High tensile steel mesh, Ref 395 will be placed in one layers in the floor slab, with 50mm cover from the bottom, as indicated in the relevant drawings.

33.5.3 READY MIX CONCRETE:

All concrete elements shall be executed with ready mix concrete, unless otherwise instructed by the Engineer.

The contractor shall take care to order ready mix concrete to the correct specifications for the specific element, and manageable quantities, in order to pour, place and finish while the concrete is workable.

33.5.4 CURING AND PROTECTION:

After formwork has been removed and as soon as it is practicable in the opinion of the Engineer, all concrete shall be protected from contamination and loss of moisture by one or more of the following methods:

- Ponding the exposed surfaces by means of water except under cold weather conditions (concrete surfaces shall not be wet intermittently by spraying or otherwise).
- Covering the concrete with sand or mats made of moisture retaining material, and keeping the covering continuously wet
- The use of an approved curing compound applied in accordance with the manufacturer's instructions. The curing period shall be at least 5days for the concrete made with Portland cement, at least 2days for concrete made with rapid – hardening Portland cement, and at least 7days if Portland blast furnace cement is used. When atmospheric temperature is below 5°C, these minimum curing periods shall be extended by 72hours, 36hours, and 72hours respectively.

33.5.5 DEFECTS:

The concrete shall be homogenous and free from honeycombing, interstices and planes of weakness. If, after the removal of the forms, the concrete shows any defect, the Contractor shall immediately report such defect to the Engineer, and shall not carry out any patching or remedial work until authorized to do so by the Engineer.

After thorough inspection and investigation of the quality and strength of the defective work and after due consideration of the possible consequences of such defect, the Engineer will either specify the extent and method of repair, or order the demolition and reconstruction of the whole of the defective work to the extent which he considers necessary.

The cost of all such investigation, repair and remedial work and of any demolition and reconstruction of defective work shall be borne by the Contractor and all repair, remedial and reconstruction work shall be executed to the satisfaction of the Engineer.

Measurement and payment will be according to the relevant section.

33.6 MASONRY WORKS

All masonry work shall comply to the specification of SECTION 4: MASONRY, and the relevant drawings.

33.6.1 BRICK WORK

Foundation walls for the structure shall be done with 140x190x390mm concrete blocks. Masonry walls will be done with 140x190x390mm concrete blocks up to 900mm above floor level or up to the first side-purlin. Brickwork for the tank stands and ramps will be of standard cement bricks, as indicated on the relevant drawings.

33.6.2 BRICK REINFORCING

Unless otherwise described, brick work reinforcement is to be of approved SA manufactured welded high-tensile steel wire reinforcing fabric of the width stated, cut to length and lapped full width at corners and passing. Rate shall be included in the rate of brick and block work, built into walls at every layer or as specified on the drawing.

Measurement and payment will be according to the relevant section.

33.7 STEEL STRUCTURE

All structural steelwork, excluding dimensions, will be according to specifications as per SECTION 6: STRUCTURAL STEELWORK, SECTION 7: METALWORK AND SECTION 10: STEEL AND POLYCARBONATE ROOF AND SIDE COVERINGS.

33.7.1 STRUCTURE FRAME WORK

- The Contractor shall indicate in his tender offer who his selected sub-contractor/supplier of the Steel Portal Frame Structure will be. This sub-contractor/supplier must be approved by the Employer's Agent before an order is created.
- The structure will be 12m wide x 18m long x minimum 3.6m high at the lowest point. The structure will consist of a steel frame structure (IPE Profiles), concrete bases (Including geotechnical investigations, design of concrete basis and excavations), constructed, assembled, and erected according to the instructions of the design engineer and manufacturer.
- The structure will be designed to withstand all applicable wind-, snow-, hail-, or any other loads which might occur in the area.

- All roof purlins, and cladding supports (lip channels) will not exceed a maximum spacing of 1,2m.
- The contractor shall provide the Engineer with an approved geotechnical investigation report with recommendation for the treatment of the subgrade, should it be required, an approved structural design certificate, drawings and specifications, as provided by the design engineer and manufacturer. The design of the structure and footings must be based on the findings and recommendations of the geotechnical report.
- The contractor and design engineer takes full responsibility and liability for the structural integrity, and construction quality.
- The structure must be manufactured in a workshop, according to all applicable specifications and standards. All sections may be transported and assembled on site. No welding may be done on site; only touch-up work to ensure an acceptable product.
- Painting of the portal frame: One (1) coat of grey etch primer and two (2) coats of QD enamel to the columns, rafters, and bracings. Painting will be done in a paint shop and only touch-ups are allowed to be done on site.
- A Certificate of Compliance will be issued by the Design Engineer to the DRDAR after completion of the structure.

33.7.2 ROOF STRUCTURE

33.7.2.1 Roof Design and Erection

Will form part of the design as supplied under clause 33.7.1.

150x100mm galvanized steel gutters with 76mm downpipes must be installed on each side to discharge into water tanks. Bends and fittings must be compatible with gutters.

33.7.2.2 Roof Angle

The roof must be a pitched roof with an angle of not less than 15°.

33.7.2.3 Roof/Roof Cover

The roof cover must be galvanized iron, IBR sheet type of a thickness of 0.5mm, Z275 galvanized coating, in one continuous sheet, as per SECTION 10.

8 x IBR-shaped white translucent sheets must be fitted, four on each side, evenly spaced. Full-length polycarbonate sheets (MODEK or similar), 1.2mm thick, with an effective span of 686mm, or to match the specifications by the design engineer.

Polycarbonate roof sheets shall be of a high quality with a co-extruded layer of UV stabilised polymer on both sides to create a weather resistant surface UV2. The roof sheets shall comply to standards UL94 (Class V-3), BS476 – Part 7 (Class 1Y), ASTM D1929 (Pass minimum of 450 °C), comply with ISO 3795.

The ridge cover must consist of 450mm standard flat galvanized ridge cover (Z150 galvanized coating). Spaces between ridge cover and sheeting must be left open for ventilation.

33.7.3 DOORS

- Two (2) x 2m wide x 3m high sliding doors openings on both gable sides of the structure.
- Two (2) x 1.5m wide x 2.5m high sliding door opening on one side of the structure.

As indicated on Plan shed drawing.

All doors must be fitted with locking mechanisms and locks (Including 2 sets of keys).

NB: The doors must form part of the engineer's design, and approved by the Employer's Agent. All opening must be closed properly.

33.7.4 CLADDING

The complete structure and all doors must be cladded with 0.5mm IBR (Z275 galvanized coating).

12 x IBR-shaped white translucent sheets (1.2m long) must be fitted, six on each side of the building as indicated on the drawings, to form three “windows” on each side. Polycarbonate sheets (MODEK or similar), 1.2mm thick, with an effective span of 2 x 686mm, or to match the specifications by the design engineer.

Polycarbonate sheets shall be of a high quality with a co-extruded layer of UV stabilised polymer on both sides to create a weather resistant surface UV2. The sheets shall comply to standards UL94 (Class V-3), BS476 – Part 7 (Class 1Y), ASTM D1929 (Pass minimum of 450 °C), comply with ISO 3795.

There must be a minimum overhang of 500mm over the block wal. Care must be taken to ensure that all openings between the wall and the bottom structural members (lip channels) and restricted to the minimum.

PC 33.8 MEASUREMENT AND PAYMENT

Item **Unit**

PC 33.8.1 Professional fees for the Structural Engineer Sum

The unit of measurement shall be the Sum Total of the professional fees.

The tendered rates for the professional fees shall be the full compensation of all the professional services required for the detail survey of the terrain, an approved geotechnical investigation report with recommendation, the treatment of the subgrade, the design of the structure including the design certificate and drawings, concrete footings, detail design of steel structure as per the drawings of the required structure and full construction supervision of the manufacturing and erection of the steel structure. The rates shall include full compensation for all professional fees, traveling time, disbursement costs and the supply of detailed complete set of design and shop drawings and copies thereof for approval, construction supervision and the issue of a certificate of compliance that the structure has been erected to the set specifications.

PC 33.8.2 Structure Steel-works (complete) Sum

The unit of measurement shall be in lump sum, for the complete steel structure. The tendered rate shall include manufacturing of the structure, transport of structure to site and off-loading, all materials (IPE sections, IPE trusses, C purlins, braces, haunches, base plates, anchor bolts & nuts etc., erection of all steelworks (structure to be bolted), excavations, foundation blocks, bracing, sheeting, cladding and fasteners, doors, labour, inspection and certification fees as specified.

33.8.3 Alluminium Gutters & Downpipes.....Sum

The unit of measurement shall include 150mmx100mm Aluminium Gutters with 100mm Alluminium Downpipes installed on both sides of the structure to deposit into the water tanks. The tendered rate shall include the supply, delivery and installation of the gutters and downpipes (including all brackets, etc.) to the manufacturer’s specifications.

33.8 PIT TOILET

The Construction of the pit toilet will be according to the specifications in SECTION 27: PIT TOILET.

Measurement and payment will be according to the relevant section.

33.9 SHEARING EQUIPMENT

All shearing equipment will be according to specifications as per SECTION 26: SHEARING EQUIPMENT.

Measurement and payment will be according to the relevant section.

33.10 PORTABLE KRAALS & FOOTBATH

All portable kraals and the footbath will be according to specifications as per SECTION 25: SMALL STOCK HANDLING FACILITIES.

Measurement and payment will be according to the relevant section.

33.11 PERIMETER FENCE (SF)

The perimeter fence will be according to specifications as per SECTION 19: STOCK FENCES. The perimeter fence will be constructed per specification of a 1.2m vermin proof fence, as indicated on the drawings. Heavy duty farm gates will be installed.

Measurement and payment will be according to the relevant section.

33.12 SHEEP PLUNGE DIP TANK

The sheep plunge dip tank will be according to specifications as per SECTION 28: SHEEP PLUNGE DIP TANK AND EVAPURATION POND.

Measurement and payment will be according to the relevant section.

34 SECTION 34: DIP TANK STORAGE SHED

34.1 SCOPE

This section covers the design, drawings, supply of all material and the construction of a Steel Storage Shed for office purposes during dipping processes as indicated on the drawings or as directed by the Engineer.

The size of the steel storage shed shall be 2,4m x 2,4m x 2,165m on the lowest point.

34.2 EARTH WORKS

All Earth Works for Site Clearance, General Earth Works and Earth Works for pipelines shall comply with the specifications as set out in Section 2 Earth Works and also to SANS 2001 – Construction Works Part BS1: Site clearance; SANS 2001 – Construction Works Part BE1: Earth Works (general) and SANS 2001-DP1 Construction Works. Part DP1: Earth Works for buried pipelines and prefabricated culverts.

Payment for Earth Works will be as set out in the relevant Measurement and Payment Clause for the Earth Works Section.

34.3 CONCRETE WORKS

All Concrete, Formwork and Reinforcement shall comply to the specifications of Section 3: CONCRETE, FORMWORK AND REINFORCEMENT

Structural Works

Applicable standard: SANS 2001 – Construction Works Part CC1: Concrete Works (structural).

Minor Works

Applicable standard: SANS 2001 – Construction Works Part CC2: Concrete Works (minor works).

Foundations

Applicable standard: SANS 2001 – Construction Works Part CM2: Strip footings, Pad footings and Slab-on-the-ground Foundations for Masonry Walling

Payment for Concrete will be as set out in the relevant Measurement and Payment Clause for the Concrete Works Section.

34.3.1 COMPACTION.

The concrete shall be fully compacted by approved means during and immediately after placing. It shall be thoroughly worked against the formwork and around reinforcement and other embedded items without displacing them.

The concrete shall be free from honeycombing and planes of weakness. Successive layers of the same lift shall be thoroughly worked together. To achieve this, the compaction tool shall penetrate through the new layer to the lower layer which shall still be sufficiently plastic to permit interknitting.

Compaction shall be carried out by mechanical vibration or (if approved) by spading, prodding, or forking. Over vibration resulting in segregation, surface laitance, or leakage, or any combination of these, shall not be permitted.

34.3.2 CURING AND PROTECTION.

After formwork has been removed and as soon as it is practicable in the opinion of the Engineer, all concrete shall be protected from contamination and loss of moisture by one or more of the following methods:

- a) Ponding the exposed surfaces by means of water except under cold weather conditions (concrete surfaces shall not be wet intermittently by spraying or otherwise).
- b) Covering the concrete with sand or mats made of moisture retaining material, and keeping the covering continuously wet.
- c) The use of an approved curing compound applied in accordance with the manufacturer's instructions. The curing period shall be at least 5days for the concrete made with Portland cement, at least 2days for concrete made with rapid – hardening Portland cement, and at least 7days if Portland blast furnace cement is used. When atmospheric temperature is below 5°C, these minimum curing periods shall be extended by 72hours, 36hours, and 72hours respectively.

34.3.3 CONCRETE SURFACES.

Exposed surfaces of concrete not finished against forms (such as horizontal or slightly sloping surfaces) shall be brought up to a plane, uniform surface with suitable screed boards.

Where a wood float or steel float finish or a screed topping or a granolithic finish is required in terms of the project specification, the concrete shall, unless otherwise stated in the project specification, be finished to the applicable tolerances specified.

Finished concrete shall have a neat, smooth, even and uniform finish free from any honeycombing. If the finish of any formed or floated concrete surface is unsatisfactory and does not conform to that specified, the Contractor will be required, at his own expense, to rub down such surface while it is still green, or, alternatively, to grind it down with carborundum or other suitable material when it has hardened, or to take other approved remedial measures to give the specified finish.

34.3.4 DEFECTS.

The concrete shall be homogenous and free from honeycombing, interstices and planes of weakness. If, after the removal of the forms, the concrete shows any defect, the Contractor shall immediately report such defect to the Engineer, and shall not carry out any patching or remedial work until authorized to do so by the Engineer.

After thorough inspection and investigation of the quality and strength of the defective work and after due consideration of the possible consequences of such defect, the Engineer will either specify the extent and method of repair, or order the demolition and reconstruction of the whole of the defective work to the extent which he considers necessary.

The cost of all such investigation, repair and remedial work and of any demolition and reconstruction of defective work shall be borne by the Contractor and all repair, remedial and reconstruction work shall be executed to the satisfaction of the Engineer.

34.4 STEEL SHED STEEL COMPONENTS

34.4.1 GENERAL

All steelwork shall comply with the requirements of the specifications as set out in Section 6: STRUCTURAL STEELWORK as well as that of SANS 2001- Part CS1: Specification for Construction Works – Structural steelwork.

All steelwork with the exception of steel reinforcement for the concrete works must be of grade 300W steel. All steel shall be painted with 2 layers of SABS approved an anti-corrosion paint and 1 layer of SABS approved grade 1 aluminum paint.

Payment for Steel Shed will be as set out in the relevant Measurement and Payment Clause for the Structural Steel Work Section.

34.4.2 STEEL FOR STEEL SHED AND TABLE

The frame of the shed and door shall be 50 x 50 x 2mm Square Tubing and 40 x 40 x 5mm HR Angle iron centre supports. All corner tubings shall be fitted with 150 x 150 x 5mm base plates.

The door shall be purpose made as per drawing and material for the frame shall be 50 x 50 x 3mm Square Tubing with 40 x 40 x 5mm HR Angle Iron centre support. The door shall be fitted with a 40 x 40 x 5mm angle iron portion to be locked with a pad lock.

The cladding cover and roof for the shed and door shall be corrugated / IBR type Chromadek sheeting of 0.5mm thickness. The cladding and roof shall be fastened by means of 6mm hook bolts or 4,5mm pop rivits.

A fixed steel table shall be fitted in the steel shed. The frame of the table shall be 50 x 50 x 3mm Square Tubing which shall be fixed onto the floor by means of rawl bolts. The table shall be fitted at the back against the steel frame of the steel shed and standing on 50 x 50 x 3mm square tubing legs. The cover for the table shall be flat sheet Chromadek of 0.5mm thickness rivied on the frame for the table.

34.4.3 CONCRETE FLOOR AND APRONS FOR STEEL SHED

The floor of the Steel Shed shall be a concrete floor of 20 MPa x 75mm thicknes and the finishing shall be by Steel float top of concrete to be level on 250micron damp proof sheet.

The aprons of the Steel Shed shall be a concrete apron of 20 MPa x 50mm thicknes and the finishing shall be by Wooden float top of concrete to be at a slope away from the steel shed.

PC 34 MEASUREMENT AND PAYMENT

Item	Unit
PC 34.1 Steel Shed Frame and Door Frame (Suquare Tubing 50 x 50 x 3mm) ...	metre
.....	(m)

The unit of measurement for Steel Shed Frame shall be the metres of square tubing used for manufacturing the steel shed and table.

The tendered rate shall be in full compensation for supply, delivery of all materials and components required to manufacture/construct the steel shed, all labour, tools and plant for the complete erection thereof as specified.

Item **Unit**

PC 34.2 Horizontal Centre Supports (Angle Iron of 40 x 40 x 5mm) metre (m)

The unit of measurement for Horizontal Centre support members shall be the metres of angle iron material used for manufacturing the steel shed structure and table.

The tendered rate shall be in full compensation for supply, delivery of all materials and components required to construct the lip channel members, all labour, tools and plant for the complete erection thereof as specified.

Item **Unit**

PC 34.3 Chromadek Corrigated/IBR sheeting to cover roof and sides of steel shed
..... Square metre (m²)

The unit of measurement for Cromadek cladding and roof sheeting shall be the square metres (m²).

The tendered rate shall be in full compensation for supply, delivery of all materials and components required to cover the steel shed, all labour, tools and plant for the complete erection thereof as specified.

Item **Unit**

PC 34.4 Flat Chromadek sheeting to cover table of steel shed Square metre (m²)

The unit of measurement for Flat Cromadek sheeting shall be the square metres (m²).

The tendered rate shall be in full compensation for supply, delivery of all materials and components required to install the flat sheet on the table, all labour, tools and plant for the complete erection thereof as specified.

35 SECTION 35: SITING, DRILLING AND TESTING OF BOREHOLES FOR STOCK WATER PUPOSES.

35.1 PROFESSIONAL SERVICES

35.1.1 GENERAL

The Purpose of the Service is to appoint a professional Geohydrologist to manage the siting, drilling and testing of a borehole/s for the purposes of providing water for the consumption of livestock, in the Eastern Cape.

Preliminary desktops studies to assess the potential of groundwater development using Department of Water and Sanitation's archived material are used as preliminary guide. Existing boreholes drilled in the 1980's had yields ranging between of 0.2l/sec - 4.8l/sec at total depths of 50m-80m. The probability of drilling successful boreholes yielding in excess of 0.25 litres per second suitable for stock watering is very high. Stock water requirements should be based on the most accurate stock units figures and per animal peak water demands that can be supplied from each borehole.

35.1.2 PURPOSE OF THIS TERMS OF REFERENCE

The purpose of this Terms of Reference is to outline the services required from a Professional Service Provider (PSP) through providing a hydrogeological service in boreholes siting, drilling and testing for stock water purposes. The Professional Service Provider (PSP) therefore must adhere and work to meet the requirements of the Department of Rural Development and Agrarian Reform and in compliance with standards SABS 10299 (2003): Development, maintenance and management of groundwater resources.

PSP's project leader or project management staff member(s) must be registered as a professional Geo-hydrologist, Technologists and/or Technicians with the South African Council for Natural Scientific Professions (SACNSP) and members of the Ground Water Division specialist group of Geological Society of South Africa (GSSA). Certified copies of membership of SACNSP and GSSA must be provided and date of certification not older than three (3) months

35.1.3 OBJECTIVES OF THE DRILLING AND TESTING OF BOREHOLES

The objective is to scientifically identify geophysical sites, drill and test boreholes for livestock drinking.

35.1.4 SCOPE OF THE PROJECT

Tasks to be undertaken to cover the scope that will fulfill the objectives highlighted in this section are as follows:

- a) A professional geo-hydrologist's desk study scientific search for and locate drilling targets which are assessed to have the greatest chance for success. Groundwater potential commentary from DWS professional geohydrologist (attached) will augment the desktop study,
- b) A professional geo-hydrologist's siting of two borehole drilling targets per site which offer the best possibility of successful boreholes, based on the information arising from the

desk study investigation and groundwater potential commentary (a). Every effort must be made to identify a target that offers the greatest chance of success in terms of borehole yield,

- c) Drilling of boreholes strictly supervised by a professional Geohydrologist and based on his/her onsite specific instructions/specifications and with adherence to OH & S regulations, at each borehole to an average depth of 100m and submit report on blow yielding tests.
- d) Perform a Constant Discharge and Recovery Tests and water chemical analysis on the successful borehole with calculations based on 12 hours test duration and Geohydrologist's recommendation for the appropriate size of pump and depth of pump installation,
- e) Provide information to beneficiaries of each successful borehole register with Department of Water and Sanitation (DWS) and obtain authorization for use of the borehole as a schedule one Domestic and stock water, and
- f) Technical/Close Out Report .

35.1.5 DELIVERABLES

Reports with technical information, conclusions and recommendations will be prepared aligned with each objective and presented to Project Managers in the Districts (Chief Engineers); these are requisite for measurement of progress of works and payments.

35.1.6 WORKING RELATIONSHIP WITH CLIENT

35.1.6.1 CLIENT – PROFESSIONAL SERVICE PROVIDER (PSP) RELATIONSHIP

The Chief Engineer of the Department of Rural Development and Agrarian Reform in the District and the Professional Service Provider (PSP) (certified Geo-hydrological professional) shall ensure that work undertaken complies with the Scope of Work described in the Terms of Reference

35.1.6.2 PROJECT MANAGEMENT, EVALUATION AND STEERING

Supervision of the project and the management of all administrative aspects, contractual management and deliverables will be conducted by the Engineering Services of the Department of Rural Development and Agrarian Reform in the respective districts. The main personnel involved include The District Chief Engineer, the Control Engineering Technician) and he Deputy Directors Coordination, who will be responsible for community engagements.

35.1.7 ORGANIZATIONAL AND PROJECT MATTERS

35.1.7.1 CLIENT

The Department of Rural Development and Agrarian Reform in the Districts will be the Client for the project and the Chief Engineers will be responsible for the supervision and control (management as well as administration of the project), supported by the Deputy Directors Coordination.

35.1.7.2 CONTRACTOR

The Principal contractor and/or sub-contractors for the geo-hydrological studies, siting, drilling, test pumping work, pump installation and all deliverables of the project must be undertaken under the supervision and approval of a professional registered with South African Council for Natural Scientific Professions (SACNSP) and be member(s) of the Ground Water Division specialist group of the Geological Society of South Africa (GSSA).

The PSP should provide a brief overview of the company, with particular emphasis on the HDI ownership status, past experience providing details of work of a similar nature undertaken relating to the ToR within the last ten years. Specific details must be given to indicate the extent to which these previous work. The responsibility of the proposed leader and other key team members (Task Leaders and Specialists) for these previous assignments (with contactable referees) must be specified as well as the contract amount and duration of the contract for each past works.

The Professional Service Provider (PSP)s are expected to appoint drilling and testing contractors as domestic subcontractors, manage and oversee all the activities of such domestic subcontractor.

An organogram must be provided indicating key positions such as Task Leader and supporting Specialists. The organogram shall also indicate the levels at which there will be interaction with the client and/or other interested bodies. Persons proposed for these positions must be identified and supported by CV's of one page each to be included in an Appendix.

Professional Service Provider (PSP)s are expected to propose a programme of work, in a logic diagram form, illustrating their understanding of the best way to organize the works. This representation should show phases of assignment, tasks within phases and, where necessary, sub-tasks. The critical path and links to other parallel activities are important and should be shown. A work programme must be presented in a Gantt chart illustrating the dates at which critical milestones can be reached.

35.1.7.3 PROFESSIONAL SERVICE PROVIDER (PSP)'S CAPABILITY AND AVAILABILITY

Brief capability statements must be given for each designated team member, emphasizing recent experience relevant to the task envisaged. The availability of each designated team member for the expected duration of the assignment must be indicated by reference to limitations that may be placed by other known commitments. The location of named personnel and budgeted man-hours must be indicated. The information must also be given on the support staff envisaged for the assignment, supported by brief CV's, also included in an Appendix

Brief statements of the capacity and availability of machinery, equipment, transport and necessary logistics the PSP's Principal Contractor and/or Sub-Contractors require for the various activities must be included in an Appendix

35.1.8 General Conditions of Contract

The General Conditions of Contract as stipulated in the Term Tenders of the Eastern Cape and standards of work as stipulated in the MINIMUM STANDARDS AND GUIDELINES FOR GROUNDWATER RESOURCE DEVELOPMENT FOR THE COMMUNITY WATER SUPPLY AND SANITATION PROGRAMME of the DWS are applicable and agreed upon. Strict adherence to the Conditions are required and will be enforced by the Client.

The contract shall be governed by the "Government Procurement General Conditions of Contract (July 2010)". These General Conditions are available for inspection at the offices of the Departmental District Office at KOMANI OFFICE at Deputy Director Supply Chain Management (SCM).

35.1.9 FINANCIAL PROPOSAL

The total estimated cost of the works should be based on the proposed work programme and manpower schedule. The Financial Proposal shall be prices according to the "PRICING SCHEDULE" provided in the bid document.

Provision must be made for VAT at 15% on the total estimated cost, not by task. A cash flow projection, estimated on a monthly basis assuming that payment will be made in the month after the work has been done, must be provided for the full programme period. VAT provision must be included in the cash flow projection.

Payment for work done on this contract will be made against monthly invoices reflecting completed tasks per objective and disbursements with documentation.

35.1.10 ENVISAGED PROGRAMME

The PSP shall provide a preliminary worksprogram, outlining all detailed activities and duration, as part of the bid proposal.

35.1.11 INVOICING

Professional Service Provider must be registered on the Provincial Treasury Database and, the BAS and LOGIS Systems of Department of Rural Development and Agrarian Reform. Invoices must be submitted to the Chief Engineer at the District of the Department of Rural Development and Agrarian Reform in good time.

Invoicing shall be accompanied by Progress report on project deliverables completed according to the specifications and authenticated by the project's Geo-hydrologist. The report must contain sufficient information and detailed activities to allow the Client to comprehensively assess the work done. The percentage of total expenditure should also be indicated. Invoices must be submitted each month if any claims arise during that month.

35.2 GENERAL CONDITIONS

35.2.1 SCOPE

This section covers the specifications for civil works and National Safety and Environmental requirements for siting, drilling, test-pumping and equipping boreholes for stock water related specifically to Section B to D of the Pricing details, in the Terms of Reference.

35.2.2 USE OF LOCALLY MANUFACTURED MATERIALS AND PRODUCTS:

Materials and products manufactured in South Africa shall be used as far as possible in carrying out the work to which this specification refers, unless an imported product is prescribed specifically, or when no suitable locally manufactured product for the specific use is available.

35.2.3 APPLICATION OF CLAUSES:

All clauses in this specification which describe the materials and methods to be used in carrying out the work specified in the specification of work to be done, or indicated on the drawings, or included in the bills of quantities, or in any detail drawings, or instructions issued by the Engineer to the Contractor during the progress of the work, shall be considered as applying to the performance of the contract.

35.2.4 SAMPLES:

The Contractor shall furnish without delay, such samples and/or certificates as called for or may be called for by the Engineer. Materials and/or workmanship not corresponding with approved samples may be rejected.

35.2.5 WATER:

Clean, fresh water free from vegetable or organic matter, earth, clay, acid or alkaline substances either in suspension or in solution, other than those used for purification thereof by the responsible authority, shall be used through-out. Where there is any reason to suspect the presence of impurities, the Engineer may require the Contractor to obtain a chemical analysis of the water by a competent analyst at his own cost. Should the water prove unsuitable for use the Contractor must procure water of an approved source.

35.2.6 UNITS OF MEASUREMENTS:

Units of measurements have been standardised in accordance with "Système International d'Unites" (SI).

35.2.7 PROFESSIONAL SERVICES

The work consists of scientifically identify geophysical sites, drill and test boreholes for delivering water for livestock drinking purposes

The work includes drilling boreholes, installation of casings and screens; provision of gravel packing; development of the boreholes; test pumping; obtaining rock and water samples; water quality analysis; platform casting and pump installation; as specified hereinafter and as directed by the Geohydrologist.

35.2.8 DRILLING SITES

The Contractor shall drill the borehole(s) at the exact location(s) designated by the Geohydrologist. Tracks required for access of drilling plant, gear, camp and accessories to the borehole site shall be made by the Contractor, and should as little as necessary interfere with existing fences and cultivated land.

35.2.9 ENVIRONMENTAL PROTECTION OF THE SITES

Care must be taken in the handling and storage of all drilling fluids, oils, greases and fuel on site, to avoid any environmental degradation. The Contractor shall dispose of any toxic materials, drilling fluids and other additives, cuttings and discharged water in a manner approved by the Geohydrologist so as not to create damage to public and private property, and shall adhere to the set of "Environmental Guidelines for Drilling and Test pumping Operations" available at Department of Water and Sanitation. The Contractor's adherence to these guidelines will be closely monitored by the Geohydrologist, and any infringement by the Contractor may render unacceptable the particular portion of the Works to which it applies. The Contractor shall ensure that all its personnel are aware of these Environmental Guidelines and the consequences of not adhering to them.

35.2.10 WORKMANSHIP

The Drilling & Testing Contractor is expected to carry out all works as instructed by the Geohydrologist in a thorough and workman-like manner, and up to today's professional standards. The Contractor shall carry out operations with due efficiency and dispatch in accordance with the terms of the contract and to the satisfaction of the Geohydrologist. For this purpose, the Drilling and Testing Contractor shall use suitable equipment, and supply efficient and experienced staff.

35.2.11 EQUIPMENT AND MATERIALS

All necessary machinery, equipment and materials to carry out the drilling, test pumping, headwork construction, etc. as specified are to be mobilized for the Works. Test pumping equipment should be independent from the drilling rig(s). Prior to mobilization the Geohydrologist will verify the specifications

and state of repair of all major items of plant and transport, and shall have the right to order the removal and/or replacement of any items which in his opinion is insufficient or in unsatisfactory condition. Acceptance by the Geohydrologist of the Contractor's proposed plant and transport does not, however, relieve the Contractor of his obligations under this Contract, in case such plant and transport accepted by the Geohydrologist or Project Engineer fails to successfully complete the required Works. All machinery, equipment and materials to carry out the said Works shall be handled, transported and stored in accordance with the manufacturers' recommendations to minimize deterioration

35.2.12 SUPERVISION OF THE WORKS.

The execution of the Works is to be supervised by the professional Geohydrologist sub-contracted and for the approval of Employer's appointed Project Manager.

35.3 DRILLING AND TESTING OF BOREHOLE/S

35.3.1 PROJECT SPECIFICATIONS: BOREHOLE INSTALLATION

35.3.1.1 NATURE OF CONTRACT

- a) The Specifications are for the drilling and testing of boreholes.
For this the Consultant and Sub-Contractor shall provide all labour, transport, plant, tools, equipment and materials and appurtenances, and shall perform all Works necessary to satisfactorily locate sites for drilling, construct and complete successfully drilled boreholes including lowering of borehole assembly with casing and screen and end cap, gravel pack at appropriate intervals and back fill, close near surface water table aquifer, cleaning and development of said boreholes, pump test for 12 hours, water quality testing both chemical and biological in accordance with this specification and to any further details as may be ordered by the Client.
- b) The Contractor shall employ only competent workmen for the execution of the Works, and all such Works shall be performed under direct supervision of an expert borehole driller/site supervisor.

35.3.1.2 GENERAL

Wherever reference is made in the Contract to specific standards and codes to be met by the goods and materials to be furnished, and work performed or tested, the provisions of the latest current edition or revision of the relevant standards and codes in effect shall apply, unless otherwise expressly stated in the Contract.

This contract comprises the hydrogeological survey, drilling, construction, development; test pumping, water quality analysis, erection of a gantry and borehole equipping. The drill sites are indicated.

35.3.1.3 REGULATIONS AND STANDARDS

The borehole shall be drilled at the site to be identified by the Geohydrologist. Each borehole shall be drilled to a depth specified in the hydrogeological survey report. It shall be drilled through all strata encountered. The contractor will acquire the relevant permits and Government authorizations on behalf of the employer.

35.3.1.4 MOBILIZATION, DEMOBILIZATION AND RESTITUTION

The Contractor shall mobilize to the site in accordance with the agreed Work Programme. The sum for mobilization/demobilization shall include transportation of machinery, erection, dismantling and preparation of temporary camps as the Contractor deems necessary, provision of drilling and development fluids (Bentonite, foam, and water), water for camping, personnel sanitary facilities.

The contractor shall minimize disturbance to neighbouring plots. This shall particularly include ensuring that bailed fines and pumped test water are discharged in a manner that does not create a nuisance either to the public or private property.

Site re-instatement under the conditions of contract shall include the removal of all hydrocarbons spilled, leaked or otherwise released and associated packaging and cotton waste. Site re-instatement is deemed an integral part of mobilization. This activity shall be costed taking into account the items above and expressed as a lump sum.

35.3.1.5 CONTRACTOR'S DRILLING EQUIPMENT

- a) The Contractor shall specify in the Schedule of Drilling Equipment, borehole development and other accessory equipment, its type and capacity that is to be used to undertake this work. Its capacity shall be sufficient to cope with the Works as stated in the Contract. It shall at all times be kept in full working order and good repair. For depths down to 150m, drilling rigs with compressor strength in excess of 21 bars will be required.
- b) If the Client considers that the drilling equipment or any accessories in use on the site of the Works is in any way unsuitable, inefficient or inadequate in capacity, the Client shall have the right to call upon the Contractor to put such equipment in good order within seven days or alternatively to remove such plant and replace it with additional plant or equipment which the Client considers necessary to meet the requirements of the Contract. In the event that this requirement of the Contract is not satisfied, the Client reserves the right to terminate the Contract immediately.
- c) No extra payment shall be made for the Contractor's change of drilling equipment, labour or other equipment required to complete the Works specified, nor for any incidentals thereto, the cost being deemed to be included in the schedule of rates.

35.3.1.6 SITE SELECTION

- a) The Contractor upon arrival in a District will meet the Employer's agent's representative from the Department of Rural Development and Agrarian Reform and inform about the drilling plans. The designated representative in consultation with communities will refer to the geographical coordinates of possible site relative to stockwater system. The Contractor shall receive from client the list of locations (Annex). Contractor upon visiting these locations will determine the road conditions for accessibility of the drilling rig and other heavy equipment. Any changes or alternative sites will be in consultation with Client and designated representatives.
- b) Within each of the selected location, the driller in consultations with designated representative or Project Engineer/Geohydrologist will select 2 sites for exploratory drilling. The Contractor will be responsible for getting sites checked by proper Geophysical/ Geological and confirm the technical feasibility of drilling a successful borehole(s) for pump installation.
- c) Sites selected will consider the rainy season and accessibility to heavy drilling rigs and support vehicles'. If the Contractor considers improvements are required for any reason to enable him carry out the Works, he shall make the improvements at his own expense. In the event that

improvement is not feasible, and access is still not possible, then the contractor should notify in writing to the client and seek permission to replace the location.

- d) At least two borehole sites shall be identified at each location, which shall constitute one single siting payable under this contract. In case the Contractor fails to drill a successful borehole move to a new site on instruction of the Geohydrologist and Employer, only.

35.3.2 BOREHOLE DRILLING

35.3.2.1 DRILLING

Unless otherwise approved by the Project Engineer in concurrence with the professional Geohydrologist, drilling shall be by the air hammer method, by flush rotary drilling or by the percussion method. Drilling shall continue through all strata encountered. Drilling fluids and additives used must be approved by the Project Engineer prior to use.

- a) The Contractor shall provide the appropriate tools and equipment and maintain them in good condition capable of operating to the manufacturer's rating to ensure a smooth, straight hole.
- b) Drilling shall continue to the stipulated maximum total depth of 120m with a minimum internal diameter casing of 165 mm to provide for a finished borehole. The Employer on the recommendation of the Geohydrologist, may approve in writing, drill work deeper than 120m.
- c) The Employer upon recommendation from the Geohydrologist, reserves the right to stop drilling operation if he considers that further drilling is unlikely to be advantageous. In this event payment shall only be made for the amount of work actually executed.
- d) All materials used in the borehole construction other than temporary works shall comply with the relevant standard specifications. A tolerance in dimensions will be permitted provided that the material quality is not inferior to specification and work is no way impaired.

35.3.2.2 DRILLING METHODS

Basic methods of drilling are indicated below as a basic guide, mostly to maintain a few key dimensional specifications.

- a) The preferred method of drilling in consolidated compact formations is rotary percussion with air and/or foam flush. However, the Contractor may use any rotary drilling technique that they feel applicable to achieve the depth and diameter required, provided that the techniques used are those specified in their proposal and is approved by a professional Geohydrologist.
- b) In unconsolidated loose, unstable, collapsing formations, rotary with appropriate drilling stabilizer will be used. In such a case the drilling diameters will be telescopic starting with diameter large enough to lower temporary casing in upper collapsing formations and continue drilling with a final minimum diameter of 165 mm bit. If other chemical fluids or solids are used to arrest collapsing of formations, the Contractor has to use proper borehole development and cleaning methods to ensure the use of borehole water is safe for stock watering purposes. The Contractor will use such fluids or solids with the agreement of the Client. In no case will the use of Bentonite mud be allowed. Boreholes will be constructed with steel casing, screen and sand trap. The Contractor will use appropriate lengths of slotted screen in the aquifer intervals on instruction of the Geohydrologist. All cost of using proper drilling fluids and solids is included in the rate per meter quoted. No additional payments will be made by client.

35.3.2.3 BOREHOLE DEPTH

The Contractor shall drill to the total appropriate depth depending on the geological formation and to a diameter that shall allow minimum borehole nominal diameter bore of 165mm casing diameter at the completion of the borehole. (including casing installation) Boreholes shall be drilled to such depths as to penetrate below the shallow water table aquifers and tap the first potential deeper aquifer or aquifers in confined/semi-confined conditions. The minimum discharge of *0.25 litres per second* to sustain continuous pump testing for 12hours to ensure reliable operations of pumping equipment fitted directly on them is acceptable. In any case the maximum drilled depth should be 120 metres, on average 100 metres depth. If the discharge is less than 0.25 litres/sec., a decision to abandon the borehole or continue to drill deeper will be at the discretion of the professional Geohydrologist on written approval of the Employer.

35.3.2.4 BOREHOLE DIAMETER

- a) Boreholes will be drilled with telescopic diameters.
- b) Borehole will be drilled with 165 mm bit. The reaming diameter will be based on the type of temporary casing the contractor will use and not less than 215 mm to install steel casing of 176mm outside diameter for the total depth of the borehole.
- c) The contractor must take into account the depths they have to drill and lower temporary casing to complete the drilling. This cost must be built in the quoted unit cost for drilling.
- d) The client will not be responsible for any loss of temporary casing which the contractor is unable to recover or lost due to snapping or breaking from the completed boreholes.

35.3.2.5 SAMPLE COLLECTION, STORAGE AND RECORD KEEPING

- a) Samples of the drill cuttings returned to the surface shall be collected at one (1) metre intervals. The Contractor shall make all samples available for inspection as per DWS requirements.
- b) The Contractor shall maintain a log of the penetration rate on a metre by metre basis, in minutes per drilled. A stop watch shall be used for this purpose so that only the net drilling time is recorded, excluding any time taken in drilling disruptions.
- c) The depth of any void, or of particular rapid penetration, or significant changes in rig noise shall also be noted.
- d) Water level shall be measured and recorded at the start and end of every shift, after significant breaks in activity (such as meal breaks), and during periods of plant downtime (as appropriate). The water levels shall be measured using a sounding and/or lighting dipper approved for use by the Geohydrologist.
- e) Representative samples of the strata intersected shall be collected every one meter or less depending on the change of geological formation. For collection, the Contractor shall cease drilling, circulate all cuttings to the surface, resume drilling and collect the cuttings then brought to the surface. The Contractor shall take every possible precaution to guard against sample contamination due to poor circulation, borehole erosion, or caving. Cutting samples shall be bagged, labelled with borehole depth at time of collection, and stored in a position where they will

not be contaminated by site conditions or drilling operations. The Contractor shall supply strong, transparent sample bags and indelible labels as required. The driller in-charge will also record the drill time logs/penetration rate of each rod or at every three-meter interval.

35.3.3 SUPPLY AND INSTALLATION OF CASINGS AND SCREENS

35.3.3.1 CASING AND SCREEN SPECIFICATIONS

- a) Casing shall be new, 215mm internal diameter and 176mm outer diameter, black pipe class B, with a minimum wall thickness of 4.0 mm in 6 meter lengths, respectively.
- b) Mill slotted screens shall be constructed from new 176mm external diameter black pipe class B with a minimum wall thickness of 4.0mm. Slots shall not exceed 1.0mm in width, and should constitute not less than 6.0% open space area.
- c) Alternative PVC casing may be approved by the Employer, in consultation with the Geohydrologist.

35.3.3.2 CASINGS AND SCREEN INSTALLATION

Installation and diameter of any temporary casing required for the successful construction of the boreholes will be at the discretion of the Contractor provided that the completed borehole meets the specifications and design required under this Contract and is approved by the Geohydrologist. The cost for supply, installation and removal of temporary casing shall be entirely for the Contractor. The Contractor cannot claim any casing left in the borehole that is not retrievable, from the Employer

- (a) Before installations of the casings and screens, the Contractor shall ensure that the hole is clear to the total depth and shall flush out any backfilled materials present. The Geo-hydrologist shall provide the design of the casings and screens string prior to installation by the Contractor.
- (b) Casing jointing shall be by either flush square-section threading or tree pass electric arc welding. Screens may be welded to casing, or screw-jointed by means of flush square-section threads. Externally socket joints may be welded to the casing, or screw-jointed by means of flush square-section threads. Externally socketed joints will not be accepted. Where screwed joints are deemed by the Project Engineer to be below standard, joint shoulders shall be spot welded at 900mm interval around the casing circumference at no extra cost. If screens and casing are to be welded, the appropriate welding electrode must be used.
- (c) During welding, casing and screen lengths must be held absolutely vertical in order to ensure a plumb installation. All joints to be welded must be bevelled at the butt end. Three continuous weld passes must be made to ensure a sound joint and the oxide coating be removed before the second and third passes.
- (d) Burn-through and subsequent deposition of metal on the inside of the casings and screens must be avoided. The base of the casing shall be sealed, unless otherwise directed by the Geohydrologist, with a circular plate of black pipe class B of thickness not less than 4.0mm fixed with a continuous weld to the casing strip. The appropriate welding electrode shall be used. The top of the casing will be made, with oxide coating removed prior to the second and third passes. The top of the casing will be straight shall terminate not less than 600mm above the highest recorded level of ground at the site.
- (e) The contractor shall be responsible for the provision of temporary casing as necessary, including the insertion and removal. Where the Project Engineer deems it necessary as recommended by the Geohydrologist, to have temporary casings left in the borehole as a measure of securing the borehole, this will be indicated in the item for other works in the bill of quantity.

- (f) The boreholes will be fully cased to stable solid formation (Estimated at 40m). The threads both male and female are properly cleaned with a clean brush and cloth before they are joined. If the pipes used are with bell and socket, these are cleaned using fluids and cemented with recommended solvent cement by the manufacturers of the casing pipes and screen. Wait for recommended time for the joint to set firmly before lowering into the borehole.
- (g) The Contractor will take all necessary precautions during the transportation and storage of casing pipes from their warehouse to drilling sites to prevent distortions, ending or deformation of the pipe that could result in eccentricity along the length of the pipe.

35.3.3.3 GRAVEL PACKING AND GROUTING (FORMATION STABILIZER)

- a) The annular space between the casing and borehole wall is filled with filter packing materials in the screen intervals and back filling materials. The gravel packing mixture to be used depends on the sieve analysis results and the slot size of the screen. The contractor will do the sieve analysis and then determine the gravel pack materials and approved by Geohydrologist. Gravel packing material will be stored in a way so as to avoid contamination or rain washing finer materials. Iron and Calcareous grains will not be included in the gravel pack materials.
- b) Gravel packing is carried out as continuous feed operations done usually by two people filling uniformly around the circumference of the pipe. It is advisable to add some water with a pipe so that the gravel flows down. If the gravel gets inside the temporary casing, the casing is slowly pulled out and gentle well development is done to allow gravel to settle properly to a height of 3 meters above the top of the screen interval or the targeted water bearing formation. More gravel is added with development if the gravel settles down.
- c) Backfilling and grouting is done when the *Minimum acceptable yield of 0.25 litres/ second* is confirmed by development. The borehole cuttings or clayey soils are back filled up to 6 meters below the ground surface.
- d) The grouting is done with a concrete mix in the ratio of 1:2:3 of cement sand and gravel respectively. The gravel size should be not more than 6mm. Casing above ground level must be at least 60cm to facilitate installation of the pump.

35.3.3.4 BOREHOLE DEVELOPMENT

A) METHOD

On completion of drilling, the Contractor will choose a suitable and appropriate borehole development method and approved by Geohydrologist. The borehole shall be developed for a period of at least two hours in order to obtain a maximum yield of water that is free of suspended matter. Developing shall be carried out by airlift pumping and surging, jetting and block surging, or other techniques the contractor feels is more appropriate and efficient to suit the casing, hydro-geological and drilling conditions prevailing in that borehole. All boreholes shall be presented for testing free of any bridging or obstruction to the total depth.

B) BOREHOLE CLEANING

- a) The contractor shall clean the borehole to its "completed depth" using any of the methods listed below or as otherwise authorized by the Geohydrologist: -
 - By bailer with percussion drilling rig

- By means of airlift, which may use a light or stable foam to assist in the removal of materials from the borehole.
 - By means of educator airlift, with or without light or stable foam.
- b) Bailers and other down hole plant shall adopt diameter limits of half a normal size or smaller (12.5mm) than the smallest casing or screen diameter.
- c) Water levels shall be measured and recorded at the start and end of every shift, at significant breaks in activity (such as meal breaks), and during periods of plant downtime (as appropriate). Water levels be measured using a sounding and /or lighting dipper previously approved by the Geohydrologist.
- d) The borehole shall be deemed clean when measured drilled depth has been reached and when insignificant or no materials is removed from the base of the borehole. Cleaning costs shall be expressed as a rate per hour.

C) PHYSICAL DEVELOPMENT

- a) Physical development may adopt any of the commonly used methods, including but not necessarily restricted to the following: -
- Surging;
 - Bailing;
 - High Velocity Water Jetting;
 - Airlift raw hiding;
 - Airlift raw hiding with educator pipe.
- b) Development shall be considered complete when the water discharged is clear and contains no more than an estimated 5 parts per million of suspended solids and the borehole has been restored to the cleaned total depth or as otherwise directed by the Geohydrologist.
- c) The Contractor shall describe the method he proposed to adopt and the plant required for physical development in his method statement. Over pumping shall not be considered a development method. The rate submitted by the Contractor for physical development is deemed to include installation and removal of necessary plant. The quantities given in the bills of quantities only apply to actual development time. Costs for physical development shall be expressed as an Hour Rate.

35.3.3.5 BOREHOLE HEADWORKS

a) SANITARY SEAL CASING

A sanitary seal shall be constructed at the wellhead. This shall be comprising of the following elements:

- A 3.2 metre length of internal diameter 205 mm (8inch) plain black pipe class B sanitary steel casing installed around the permanent casing string.
- A grout seal between the 254mm sanitary seal casing and the 165 mm permanent casing string.
- A 1.0x1.0x1.0 meter reinforced concrete block (Y8/1:2:4) cast around the Sanitary seal casings or alternative.
- A lockable steel cap.

b) GROUT SEAL

A sanitary ground seal shall be installed between the 165 mm and 205 mm casings and grouted into place. Grout shall be a cement slurry, or cement and fine sand and shall have a density of at least 1175kg/lt. This shall be introduced into the annular space from the top of the inert backfill to the ground level, using a method that must be approved by the Geohydrologist.

c) CONCRETE PLINTH

The ground surface at the wellhead shall be excavated to a depth of one (1) meter, and be one metre square, to allow Concrete Plinth to be cast. The 1.0x1.0x1.0m pit will be filled with concrete, to be finished flush with the ground surface. Concrete shall be 1:2:4 OPC: sand: 12.5mm ballast. This must be cast with two 0.8 metre lengths of 12mm reinforcing steel bar welded to the 205 mm (8 inch) casing, 0.7 meter below ground level.

d) TEMPORARY CAP

The top of the borehole shall be sealed with a cap that shall comprise a round plate of mild steel, of thickness not less than 3.0mm. This will be continuously welded in single pass to the mild steel borehole casing or should be lockable.

35.3.3.6 VERTICALITY

All boreholes shall be vertical, shall be drilled and cased straight, and all casings/screens shall be set round, plumb and true to line. If required by the Geohydrologist, the Contractor will make a verticality test during and after drilling by approved methods and at their own expense to demonstrate that the departure from the vertical does not exceed 3mm per 1,000mm between ground level and the bottom of the borehole. If this departure is exceeded, the Contractor shall make the necessary corrections to the approval of the Geohydrologist, without additional payment.

If the error cannot be corrected, then drilling shall cease, and a new borehole shall be drilled at a position nearby, indicated by the Geohydrologist. The abandoned borehole shall be backfilled and/or capped by methods approved by the Geohydrologist. No payment will be made for the re-drilling, the sealing/backfilling of the abandoned borehole, or for moving to the new site. Any materials (i.e. casing, screens, gravel pack, cement, etc.) lost in the abandoned borehole will be to the Contractors cost.

35.3.4 WATER SAMPLING AND ANALYSIS

- In the closing hour of the constant discharge test a water sample shall be collected for chemical and bacteriological analysis by a competent laboratory. The water samples shall be collected in containers supplied by the laboratory, in the manner conventionally used by the laboratory.
- The Contractor's unit rate of sampling and analysis will include the cost of analysis and transportation to and from the laboratory for the sampling exercise.

35.3.4.1 BOREHOLE DISINFECTION

After removal of test equipment, the borehole shall be disinfected with Chlorine/Water solution at a concentration of 50 milligrams per litre or greater of free chlorine. In preparing their Tenders, Contractors should allow for one (1) cubic metre of solution per borehole. This item shall be costed as a unit Lump Sum.

35.3.5 PUMPING AND RECOVERY TEST

The Contractor shall perform test pumping to establish the performance and yield of the borehole, and shall provide a suitable, self-contained, mobile test pumping unit, approved by the Supervisor, for this purpose. The method for varying the discharge rate of the pumps will depend on the type of pump used, but the Contractor shall ensure the provision of a suitable means of achieving the range of constant flow rates specified by the Geohydrologist.

A pumping test is required on a routine basis for each borehole. The Contractor will estimate the discharge from the air lifting rates or blow test during borehole development. Based on the estimated discharge, the Contractor will certify the borehole as either "successful" or "lost". For successful boreholes for hand pumps, the Contractor will undertake a four hour step down pump testing of which the first one hour is a three step draw down test. The discharges for the step drawdown test will be fixed by the contractor based on the well development results. High yielding boreholes, with a discharge of more than 1 litre/second may be pump tested for 12 hours or as recommended by the Geohydrologist.

35.3.5.1 AQUIFER TESTING

Borehole testing will be conducted according to SANS 10299 – 4:2003 (Development, maintenance and management of groundwater resources Part 4: Test-pumping of water boreholes). The following elements are required.

- Calibration test;
- Step-drawdown test;
- A constant discharge test;
- A recovery test.

35.3.5.2 CALIBRATION TEST

- A calibration test requires that water be pumped from the borehole at three or more different rates over short (15 minutes), sequential periods of time. The response of the water level to each known pumping rate is measured and recorded. The calibration test provides a means of assessing the yield potential of borehole according to the magnitude of the water level decline associated with each pumping rate. This information is used to select appropriate pumping rates at which to perform a stepped discharge test or a pumping rate at which to perform a constant discharge test.

35.3.5.3 STEP DRAWDOWN TEST

- The step drawdown test will comprise four (4) steps tests of sixty (60) minutes each, with no recovery phase between successive steps. The step draw-down test shall not start until water level has returned to the true static water level, unless otherwise directed by the Geohydrologist.
- Typically, individual step discharges would comprise 50%, 75, 100, and 125% of the anticipated production discharge rate.
- Discharge increments shall be effected as nearly instantaneously as possible and once set shall not be changed except by instruction of the Geohydrologist.
- Discharge variations and measurement shall be effected by means of the globe valve and manometer gauge as follows;

A globe valve of suitable diameter shall control the discharge and on the upstream side of this, not closer than six (6) pipe diameters from the valve, a manometer tapping and gauge will be installed such that it can be clearly seen by any person using the valve. This will be used during the step drawdown tests for the flow control purposes.

35.3.5.4 CONSTANT DISCHARGE TEST

Constant discharge test shall typically last not less than twelve (12) hours, or as otherwise determined by the Geohydrologist. A water Sample will be procured towards the end of the test for subsequent analysis by a competent laboratory.

35.3.5.5 RECOVERY TEST AND REMOVAL OF PLANT

Recovery tests shall not continue for more than twenty-four (24) hours, or as otherwise directed by the Geohydrologist. Only after the completion of recovery data collection may pumping and ancillary plant be removed from the borehole, though above ground components may be dismantled during the recovering phase.

35.3.5.6 INSTALLATION, PLANT AND METHODOLOGY

- a) Pumping plant and dipping tube shall be installed in the borehole to be tested. The Contractor shall investigate and agree with the Geohydrologist/Project Engineer the anticipated discharge and pump intake depth.

The 12 hours pump test is conducted if the borehole is intended for a motorized pump. After conducting the step drawdown tests the borehole should be allowed to recover almost to the original static water level (1 hour) before the constant yield test is undertaken continuously for 4 hours at the chosen/predetermined rate.

- b) The first step could be minimum acceptable discharge of 0.2 litres / sec. The second step will be at an estimated discharge from blow test (during the well development) and the third step will be 50 to 75% more than the estimated discharge from blow test. As a thumb rule the range of the three steps could be 0.5 litre/sec or above depending of development results, 0.75 litres /Sec and 0.2 litres/sec. and each step for 20 minutes (total 1 Hours) the continuous test of 4 hours will be carried out at a discharge at which the dynamic water level will stabilize. *If the discharge is below 0.25 litres/second, the borehole will be regarded as "Lost". If the dynamic water level is deeper than 60m, the decision on the viability of the borehole will be taken by the Employer, in consultation with the Geohydrologist.*
- c) Recovery test will be for one hour or such time when there is at least recovery of 80% of the static water level noted at the start of the pump test. The pump test data and the results of pump test is presented in the standard form attached.
- d) The Contractor shall have on site a 90° V-notch weir, preceded by a tank with baffles, for the measurement of flows. Small flows (less than 0.2 litres/second) can be measured by timing the filling of a vessel of known volume. The Contractor shall also have on site an operating electric dip meter, calibrated in centimeters, and with visual/audible indicator of when the water level is reached.
- e) Readings of flow and water level shall be taken at the intervals defined on the test pumping form. For accurate measurement, an electrical/ sonic water level indicator with graduated tape for taking water level readings should be utilized. Recovery readings shall be taken for a minimum of 1 hour, during which period pumping equipment shall **not** be removed from the borehole.

35.3.5.7 PUMPING PLANT

- i) Pumps used for test pumping may electrical submersible or surface-mounted turbine pumps or reciprocating pumps.
- ii) Any pump used in tests must have a fully functioning non-return valve either in the pump itself or in the rising main immediately above the top of the pump.

- iii) The Contractor must have pumps covering the anticipated discharge range.
- iv) The water pumped from the borehole shall be discharged to waste at a distance and in such a manner that it does not pond or flow back towards the borehole.
- v) The Contractor must provide a generator or other prime mover for powering the pump, as power is not necessarily available at the sites.

35.3.5.8 DISCHARGE MEASUREMENT AND CONTROL

Discharge measurements shall be by an approved accurate method, such as an Orifice Plate, calibrated flow meter or a V-notch weir. If volumetric methods are proposed, the Contractor will ensure the container to be used has been calibrated. When time to fill measurements is made, each discharge measurement shall be calculated from the average of three time measurements. Discharge shall vary by no more than 15% across each step of step drawdown test, and across the constant discharge test.

35.3.5.9 WATER LEVEL MEASUREMENT

Water level measurements shall be by electric sounding and/or lighting dipper, and shall be made in a dipper tube installed alongside the test pump rising main and tied securely to it. The Geohydrologist/Project Engineer will check the dipper for stretch and any other inaccuracies prior to accepting its use. Accuracy measurements must not be less than 1.0 cm. Water level measurements using an airline will not be acceptable on the grounds of poor precision.

35.3.5.10 ADMISSIBLE RATES

Rates of pumping and recovery are deemed to include the cost of plant installation and removal. The rates are deemed inclusive of installation, removal, plant use, testing and data collection.

The pre-test will check all equipment, determine the range of discharge for the step draw-down test and set the globe valves for the first step discharge rate. Pre-test shall not exceed three (3).

35.3.5.11 TIME MEASUREMENT

All times shall be measured by means of a stopwatch. The Contractor shall ensure that spare batteries etc. for all equipment are available prior to commencing tests.

35.3.5.12 WATER QUALITY TESTING

- a) The contractor shall, make sampling and quality analysis of water from every borehole.
- b) The water quality test should be conducted at a competent testing laboratory that is authorized by the client.
- c) Water samples for chemical analysis should be collected at the end of the test pumping process and analyzed at the approved laboratory at the earliest possible time to facilitate timely handing over of the borehole for use by the community. Samples for biological testing will be collected later in suitable batches so as to meet the time limit of 48 hours between collecting and analysis in the laboratory.

35.3.6 CHLORINATION AFTER BOREHOLE COMPLETION

Each successful borehole must be chlorinated following completion drilling operations. The Contractor will decide on the concentration of chlorine based on the volume of water in the borehole.

35.3.7 PROTECTION

During the contract period, when work is not in progress, the boreholes shall be kept capped in such a manner as to prevent the entrance of foreign materials. The Contractor shall remove any foreign matter at his own expense. On completion of each borehole, the Contractor shall supply and fit an approved permanent lock-up cap. Casing shall terminate not less than 0.5 meters above ground level and are fitted with the approved lock-up cap.

After successful completion of drilling, casing and testing head-works will be constructed in line with the guidelines which forms part of the documentation of this contract.

35.3.8 ABANDONMENT, LOST AND DRY BOREHOLES

- a) The Employer shall have the right at any time during the progress of the Works, upon advice of the Geohydrologist, to order the abandonment of the borehole. The Contractor shall thereupon remove the drilling rig, withdraw any casing and screen and salvage all such materials as the Client shall direct, and shall fill and leave the borehole to the satisfaction of the Client. In such case all works done and materials used will be paid by client.
- b) "Lost" (unsuccessful) boreholes are either "dry" boreholes or "uncompleted" boreholes.
- c) Dry boreholes are defined as:
 - A borehole having no water bearing zones/aquifers.
 - A Borehole that has insufficient discharge (less than 0.25 litres/second) for 12 hours of continuous pumping test.
 - A borehole that has failed verticality test (see section 8).
 - A borehole of which the chemical analysis of the water fails the minimum requirements of water for livestock consumption.

PC 35 MEASUREMENT AND PAYMENT

The fee for professional services listed above and rendered in accordance with the Scope of Work shall be calculated as follows:

Item	Unit
PC 35.1 Preparation of Project Execution Plan.....	Sum

The bid rate for the project execution plan will be a Sum. The cost will include all cost likely to be encountered for the project preparation plans, including disbursements.

Item	Unit
PC 35.2 Desktop Study	Sum

The bid rate for the desktop study will be the a Sum. The cost will include all cost likely to be encountered for the assessment of groundwater resource potential, preparation of reports for each site, including disbursements.

Item	Unit
PC 35.3 Hydro-Census Field Survey	Number

The bid rate for field survey services will be number of sites for Hydro-Census field surveys. The rate will include exploration of all possible borehole drilling targets on the different sites, GPS and mapping of identified borehole targets at each site, and risk analysis of each site. Provide the client with an interim report detailing the potential of striking water on the recommended targets for drilling and cost estimates of drilling and testing on the identified borehole targets on the different sites, including disbursements.

Item	Unit
PC 35.4 Site Selection: Geo-hydrological and Geophysical investigations	Number

The bid rate for the site selection of new boreholes will be the number of new boreholes to be sited. The rate will include all costs for personnel and equipment used to execute geological reconnaissance and geophysical site investigation to confirm the potential sites for groundwater exploration per project area for new boreholes, including disbursements.

Item	Unit
PC 35.5 Drilling of new boreholes:	Number

The services shall include the preparation of specifications for the drilling sub-contractor, calling for quotations, appoint drilling sub-contractor, supervise and oversee the drilling activities, payment to sub-contractor and health and safety Agent responsibilities on behalf of the Client. The rate will include all costs for personnel and equipment used to oversee and control of drilling operations per project area for new boreholes, including disbursements.

Item	Unit
PC 35.6 Yield and water quality testing of new boreholes	Number

The bid rate for the yield and water quality testing of new boreholes will be the number of new boreholes tested. The rate will include all costs for personnel and equipment used to appoint and manage a suitable experienced borehole yield testing sub-contractor and execute a Calibration test, Step test and Constant discharge rate test, collect one water sample per borehole. The services shall include the preparation of yield testing specifications for the drilling sub-contractor, supervise and oversee the yield testing activities, payment to sub-contractor, including disbursements.

Item	Unit
PC 35.7 Technical Report / Close out Report	Number

The bid rate for the project technical and close-out report will be a Sum. The rate will include all cost likely to be encountered for personnel and equipment used to complete the detail Technical / Close-Out Report for the implementation of identified projects. Disbursements will be paid separately, including disbursements.

Item	Unit
PC 35.14 Casing.....	Meter

The unit of measurement for the casing shall be in meter.

The rate shall be in full compensation for the the supply, deliver and installation of the borehole casing of the diameter and material as specified in the bill of quantites. The contractor shall supply a detailed drilling log as proof of measurement.

Item	Unit
PC 35.15 Recovery of Casing	Meter

The unit of measurement for the recovery of casing shall be in meter.

The rate shall be in full compensation for the the recovery of casing froman unseuccessful borehole for re-use. The contractor shall supply a detailed drilling log as proof of measurement.

Item	Unit
PC 35.16 Formation stabilizer	Kg

The unit of measurement for the formation stabilizer shall be in kilogram.

The rate shall be in full compensation for the supply, delivery and installation of the formation stabilizer as specified.

Item	Unit
PC 35.17 Borehole development	Hour

The unit of measurement for the borehole development shall be in hours.

The rate shall be in full compensation for the borehole development as specified.

Item	Unit
PC 35.18 Borehole collar/plinth	Number

The unit of measurement for the borehole collar shall be in number.

The rate shall be in full compensation for the supply, delivery of materials and installation of the borehole collar/plinth.

Item	Unit
PC 35.19 Sanitiray Seal	Number

The unit of measurement for the borehole sanitary seal shall be in number.

The rate shall be in full compensation for the supply, delivery of materials and installation of the borehole Sanitary Seal.

Item	Unit
PC 35.20 Borehole Disinfection.....	Number

The unit of measurement for the borehole disinfection seal shall be in number.

The rate shall be in full compensation for the supply, delivery of materials and execution of the borehole disinfection.

Item	Unit
PC 35.21 Borehole Protection	Number

The unit of measurement for the borehole protection shall be in number.

The rate shall be in full compensation for the supply, delivery of materials and installation of the borehole protection.

Item	Unit
PC 35.22 Borehole marking	Number

The unit of measurement for the borehole marking shall be in number.

The rate shall be in full compensation for the supply, delivery of materials and installation of the borehole marking.

Item	Unit
PC 35.23 Borehole Testing	Hours

The unit of measurement for the borehole testing shall be in hours.

The rate shall be in full compensation for the respective tests forming part of the borehole testing.

Item	Unit
PC 35.23 Chemical Analysis	Number

The unit of measurement for the chemical analysis shall be in number.

The rate shall be in full compensation for the chemical analysis of water, including but not restricted to the laboratory fees, transport, and reporting.